



EARLY DESIGN GUIDANCE 2

**9218 18th Ave SW
Seattle, WA 98106**

SDCI PROJECT NO.:

3036383-LU
3036384-LU
3036524-EG

MEETING DATE:

XX.XX.21 **DRAFT**

APPLICANT TEAM:

AKA Investors, Developer
Caron Architecture, Architect
GHA Landscape Architects, Landscape Architect

CARON

CARON REF #2020.009



OPTION 5 (PREFERRED)

CONTENTS

03 Development Objectives	pg. 3
03 Summary of Public Outreach	pg. 4
04 Survey / Tree Survey	pg. 6
04 Site Plan	pg. 7
04 Landscape Plan	pg. 11
05 Urban Design Analysis	pg. 14
05 9-Block Model	pg. 22
06 Zoning Data	pg. 25
07 Design Guidelines	pg. 26
07 Responses to EDG 1	pg. 28
08 Architectural Massing Concepts	pg. 38
Option 4	pg. 40
Option 5 (Preferred)	pg. 48
09 Departures*	pg. 55
Appendix 1:	pg. 56
Additional Studies for EDG2	
Appendix 2:	pg. 64
EDG1 Option 1	
EDG1 Option 2	
EDG1 Option 3	

*No departures requested

PROJECT TEAM

OWNER

Harry Arsene & Alicia Arsene, AKA
Investors, LLC

CARON ARCHITECTURE CONTACT

Andrew Kluess, Associate Principal
andrewkluess@caronarchitecture.com
206.367.1382
Caron Reference No.: 2020.009

PROJECT HISTORY

EDG 1

10.15.20

SITE INFORMATION

ADDRESS:

9218 18th Ave SW Seattle, WA 98106

SDCI PROJECT NO.:

3036524-EG
3036383-LU
3036384-LU

PARCEL(S):

9352900275, 9352900270, 9352900265

SITE AREA:

13,772 sf

ZONING:

NC3-55 (M)

OVERLAY DESIGNATION:

Westwood-Highland Park (Residential Urban
Village), Airport Height Overlay (Conical
Surface)

PARKING REQUIREMENT:

None

LEGAL DESCRIPTION:

WHITE CENTER ADD
Plat Block: 2
Plat Lot: 17-19

DEVELOPMENT STATISTICS

EDG 2:

Building Height: 55'-0"
Allowable FAR: 3.75 (51,645 sf)
Proposed FAR: 3.39 (46,705 sf)
Residential Units: 56
Parking Stalls: 28
Bike Parking: 57 Long-term, 6 Short-term

EDG 1:

Building Height: 55'-0"
Allowable FAR: 3.75 (51,645 sf)
Proposed FAR: 3.58 (49,244 sf)
Residential Units: 59
Parking Stalls: 25
Bike Parking: 60 Long-term, 10 Short-term

3.0 DEVELOPMENT OBJECTIVES

DEVELOPMENT OBJECTIVES

This proposal includes a five-story mixed-use residential building with on-site parking and ground-floor commercial space. Twenty-eight parking stalls are proposed below grade despite there being no minimum requirements. The street frontage will be comprised of ground level commercial space along 18th Ave SW and Delridge Way SW. Parking access is proposed along the alley while the residential access is proposed on the northwest corner of the site along 18th Ave SW. The development aims to become a welcomed addition to the neighborhood and a desirable place to call home for dozens of new neighbors. The objective is to create an aesthetically pleasing space that also functions for the neighborhood and its residents in equal measure.

SITE DESCRIPTION & ANALYSIS

The site is comprised of three parcels on the east of the intersection of Delridge Way SW and 18th Avenue SW. Existing single family residences have been removed. The lot has a minimal slope with the alley sloping down roughly two feet from north to south and the sidewalk along 18th Ave SW is relatively flat. The site is located in an area of increasing density and is transitioning to more mixed-use development with the Westwood Village being located just a few blocks west of the site. A small greenspace termed the Delridge Triangle is located west of the site across 18th Ave SW and pedestrian passage to the greenspace is commonly accessed along Delridge Way SW. Five-foot wide sidewalks currently line Delridge Way SW and 18th Avenue SW and are proposed to be brought up to current SDOT standards for width and location. Overhead power lines run down Delridge Way SW, 18th Avenue SW, and the alley and further impact the proposed designs due to setback requirements. Existing trees on site are to be removed, and new street trees per SDOT standards are to be provided on Delridge Way SW and 18th Ave SW.

ZONING ANALYSIS

As of early 2019, the site has been upzoned from C1-40 to NC3-55 (M). This means that the site has a maximum building height of 55' and mandatory housing affordability (MHA) standards are in effect. Multifamily residential and commercial uses are allowed as well as on-site parking. However, no parking is required due to the site's location in the Westwood-Highland Park Urban Village and its proximity to public transportation routes. See 'Zoning Data' on page 25 for more specific information.

TRANSPORTATION

Delridge Way SW is a principle arterial that serves multiple bus routes. Route 60 provides access to downtown Seattle while route 128 provides local access in West Seattle south towards Southcenter. 18th Avenue SW is a local access street with no bus routes. There are designated bicycle lanes on 16th Avenue SW connecting to a shared bike/bus/auto lanes on Delridge Way SW. SDOT is planning on including bike lanes on Delridge Way SW (see page 10).

NEIGHBORHOOD DESIGN

The surrounding neighborhood has some common building typologies. To the east and northeast of our site is primarily 3-story townhouses. To the southwest across Delridge is primarily single family homes across Delridge Way SW. 1-story retail is also a predominant typology found in the area starting from White Center and continues up north along Delridge in a less concentrated manner. Some newer 4-story mixed-use apartments with more modern aesthetics have recently been developed just to the north along Delridge. The mixed-use structures, both new and old, are mostly low-rise and vary between one-story to four-stories tall. With the exception of local churches in the area, the proposed project with its recent upzone will be the tallest building in the near vicinity.

DEVELOPMENT SUMMARY (PREFERRED OPTION 3)

LEVEL	GROSS SF	FAR SF	RESIDENTIAL GSF	COMMERCIAL GSF	RESIDENTIAL UNIT COUNT	PARKING STALLS	BIKE STALLS
ROOF	546	461	546	-	-	-	-
5	9,037	8,763	9,037	-	14	-	-
4	9,037	8,763	9,037	-	14	-	-
3	9,037	8,763	9,037	-	14	-	-
2	9,037	8,763	9,037	-	14	-	-
1	11,343	11,192	7,478	3,865	-	-	56
P1	12,183	-	12,183	-	-	28	-
TOTAL	60,220 SF	46,705 SF	56,355 SF	3,865 SF	56 Units	28 Stalls	56 Stalls

3.0 SUMMARY OF PUBLIC OUTREACH

COMMUNITY OUTREACH SUMMARY

As part of the Department of Neighborhoods requirements for community outreach, the design team opted to engage in a ‘high-impact’ method to spread awareness of the proposed project. This method includes a printed, digital, and in-person means to discuss the project with its neighbors and to gain valuable insight on any concerns they have and what they’d like to see in the development.

		HIGH-IMPACT	OUTREACH PROPOSED	OUTREACH CONDUCTED	
PRINTED	c	<ul style="list-style-type: none"> Direct mailings to all residences and business within approximately 500 ft. radius of the proposed site. 	<ul style="list-style-type: none"> A folded mailer will be sent to residences and businesses within an approximately 500 ft radius of the proposed site, including apartments and other multi-family buildings. The mailer will include information about the project and associated webpage, hotline, and online survey. The mailer will be sent 21 days before the survey closes and will included infomation in Spanish. 	<ul style="list-style-type: none"> June 22, 2020 - August 14, 2020 	
DIGITAL/ELECTRONIC	a	<ul style="list-style-type: none"> Online survey 	<ul style="list-style-type: none"> The online survey will include basic background information on the project and ask questions inteded to solicit priorities and concerns from community members. The survey will be available for 3-4 weeks and will be available in Spanish. 	<ul style="list-style-type: none"> June 22, 2020 - July 15, 2020 	
	b	<ul style="list-style-type: none"> Project hotline 	<ul style="list-style-type: none"> The project hotline will include recorded, current information about the project, how to find the webpage, info on the online survey, and the option to leave a voicemail. Outreach team members will return calls. The hotline will be available for 6-8 weeks and will be available in Spanish. 	<ul style="list-style-type: none"> June 22, 2020 - August 14, 2020 	
		MULTI-PRONG			
	a	<ul style="list-style-type: none"> Basic Project Webpage 	<ul style="list-style-type: none"> The project webpage will have information about the project and its design considerations, as well as an opportunity for community members to share feedback via and embedded online survey. The webpage will be available for 6-8 weeks and will be available in Spanish. 	<ul style="list-style-type: none"> June 10, 2020 - August 14, 2020 	
	b	<ul style="list-style-type: none"> Email to Community Organizations 	<ul style="list-style-type: none"> Email sent to distribution list that included community organizations identified by DON. The email will introduce the project, information about the webpage, hotline, and online survey, and an attached project factsheet. The email will be sent 21 days before the survey closes. 	<ul style="list-style-type: none"> June 22, 2020 - August 14, 2020 	

METHOD 1: PRINTED

Fliers were mailed to every resident and business in a 500 foot radius around the site to inform the neighborhood about the site, information pertaining to its proposed development and a link to the project webpage, hotline, and online survey.

COMMUNITY OUTREACH MAILER

New development is on the way: Weigh in early!
Nueva urbanización está en camino: ¡Comparta su opinión temprano!



**9218
18th Ave SW**

We want to hear from you!
¡Queremos escucharlos!

Visit the project webpage to learn more and take the early design survey:
 Para obtener más información y realizar una encuesta de opinión sobre el diseño del proyecto, visite:

18thAveSWearlydesign.com



Contact Us: Kate Graham
 Email | Correo electrónico: 18thAveSWProject@Cascadiaconsulting.com
Contáctanos: Project Hotline | Teléfono: 206-337-7374

Go online to share your feedback on the redevelopment of 9218 18th Ave SW.
Any information collected may be made public.

Visita la pagina web para compartir su opinión sobre la reurbanización de 9218 18th Ave SW.
Cualquier información recopilada puede hacerse pública.

➔ 18thAveSWearlydesign.com

The proposed 5 story mixed-use apartment building will include ground floor commercial space, 76 residential units, a below grade parking lot, bike parking, and an outdoor courtyard.

El edificio de apartamentos de uso mixto de 5 pisos propuesto incluirá un espacio comercial en la planta baja, 76 unidades residenciales, un estacionamiento debajo del grado, estacionamiento para bicicletas y un patio al aire libre.

[Blank space for postal service]

3.0 SUMMARY OF PUBLIC OUTREACH

METHOD 2: DIGITAL/ELECTRONIC

1. Online Survey: An online survey was created to accompany the distributed fliers and in-person meeting and remained open from June 22 to July 15 2020. 9 people responded to the survey citing concerns over affordability, sustainability, local businesses, pedestrian accessibility, parking and safety.

CONCERNS

- It may feel out of scale with the other buildings nearby
- Driving and parking will become more difficult
- Pricing of the units in the building
- This is a racially diverse neighborhood and projects of this scale typically bring homogenous renters

COMMENTS

- Would like to see a ground floor commercial retailer
- Many families with children live in this area, and an outdoor play areas would be nice
- There is a lack of parking in the neighborhood

2. Project Hotline: The project hotline phone number was set up and launched on June 16, 2020 and was listed on web and print materials. The outgoing voicemail message was recorded in English and Spanish, but no voicemails were received during the project. The project hotline email address was also listed on web and print materials and was used to sending emails to community organizations.

No voicemails from the residents or community organizations were received during outreach.

3. Basic Project Webpage: The project website was launched on July 10, 2020. The website included a project overview, design approach, hotline information and the ability to take the feedback survey. All pages were translated to English.

4. Email to Community Groups: An email was sent inviting community organizations to provide feedback on the project to 17 organizations on July 29, 2020. The email included a PDF of the direct-mail postcard.

No emails from community organizations were received during outreach.

SNAPSHOT OF PROJECT WEBPAGE

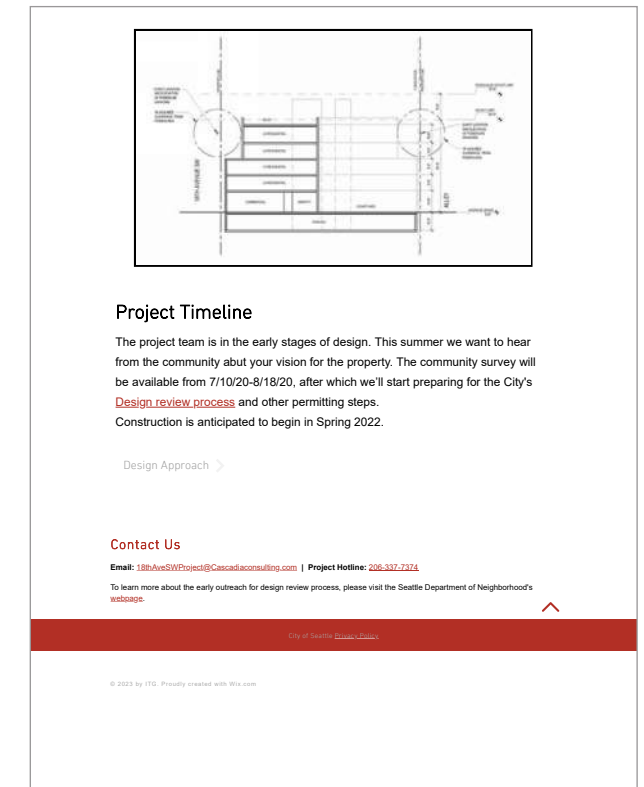



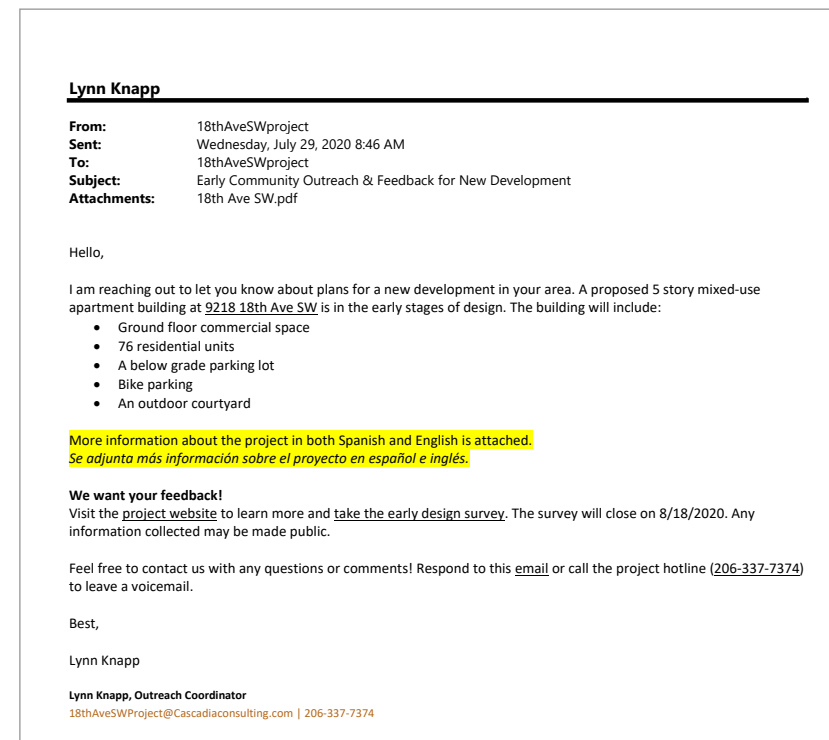



EMAIL TO COMMUNITY GROUPS



4.0 SURVEY / TREE SURVEY

KEY

-  Existing Concrete Footing
-  Existing Trees
-  Alley
-  Property Lines
-  Overhead Powerlines
-  Water Lines
-  Sewer Lines

TREE SURVEY

1. 12" Fir
2. 14" Pine
3. 17" Cherry
4. 22" Juniper
5. 14" Pine
6. 15" Cherry
7. 22" Cedar

No exceptional trees present

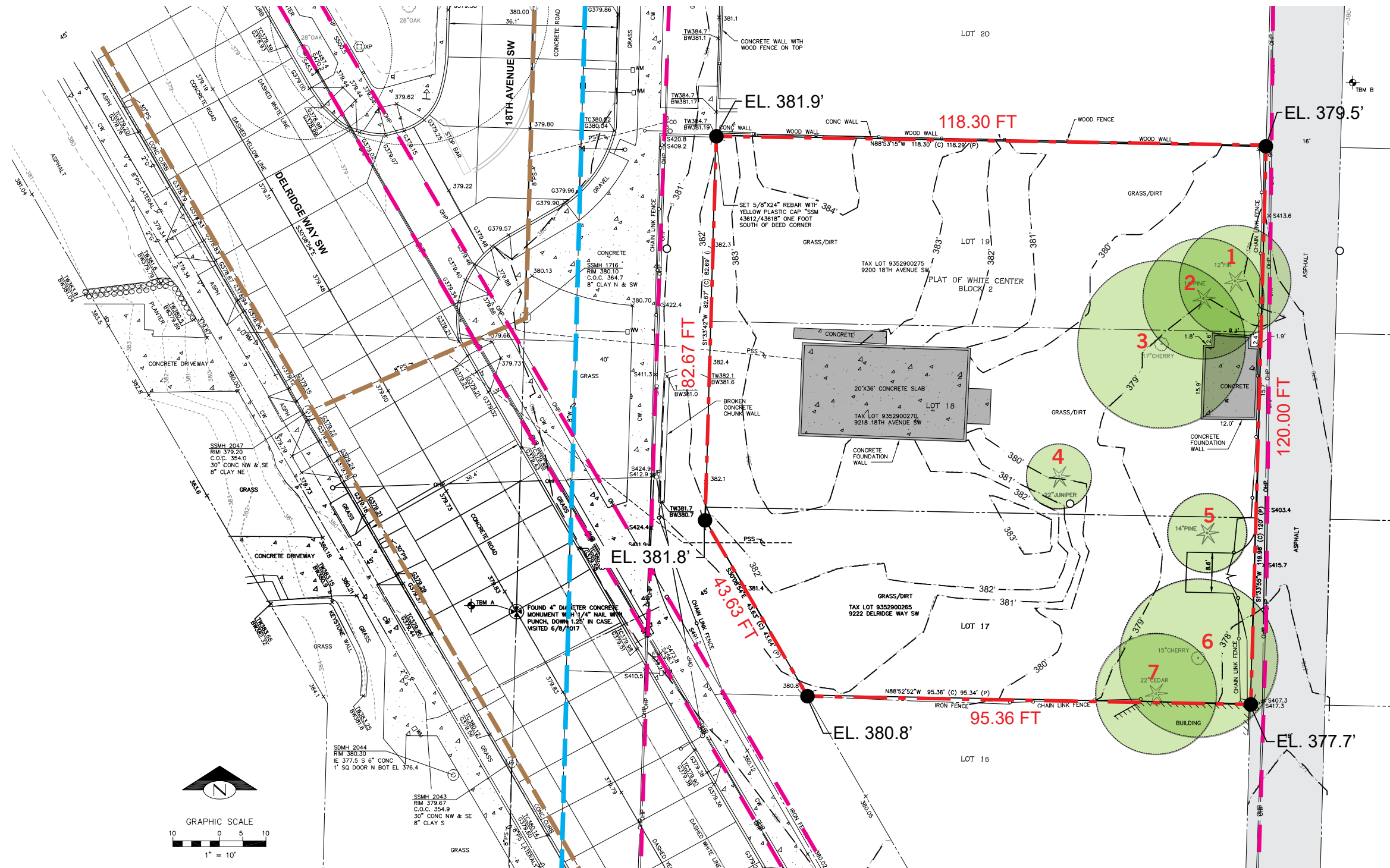

4.0 SITE PLAN

- Landscape Area
- Commercial Access
- Residential Access
- Trash Access
- Vehicular Access
- Overhead Powerlines

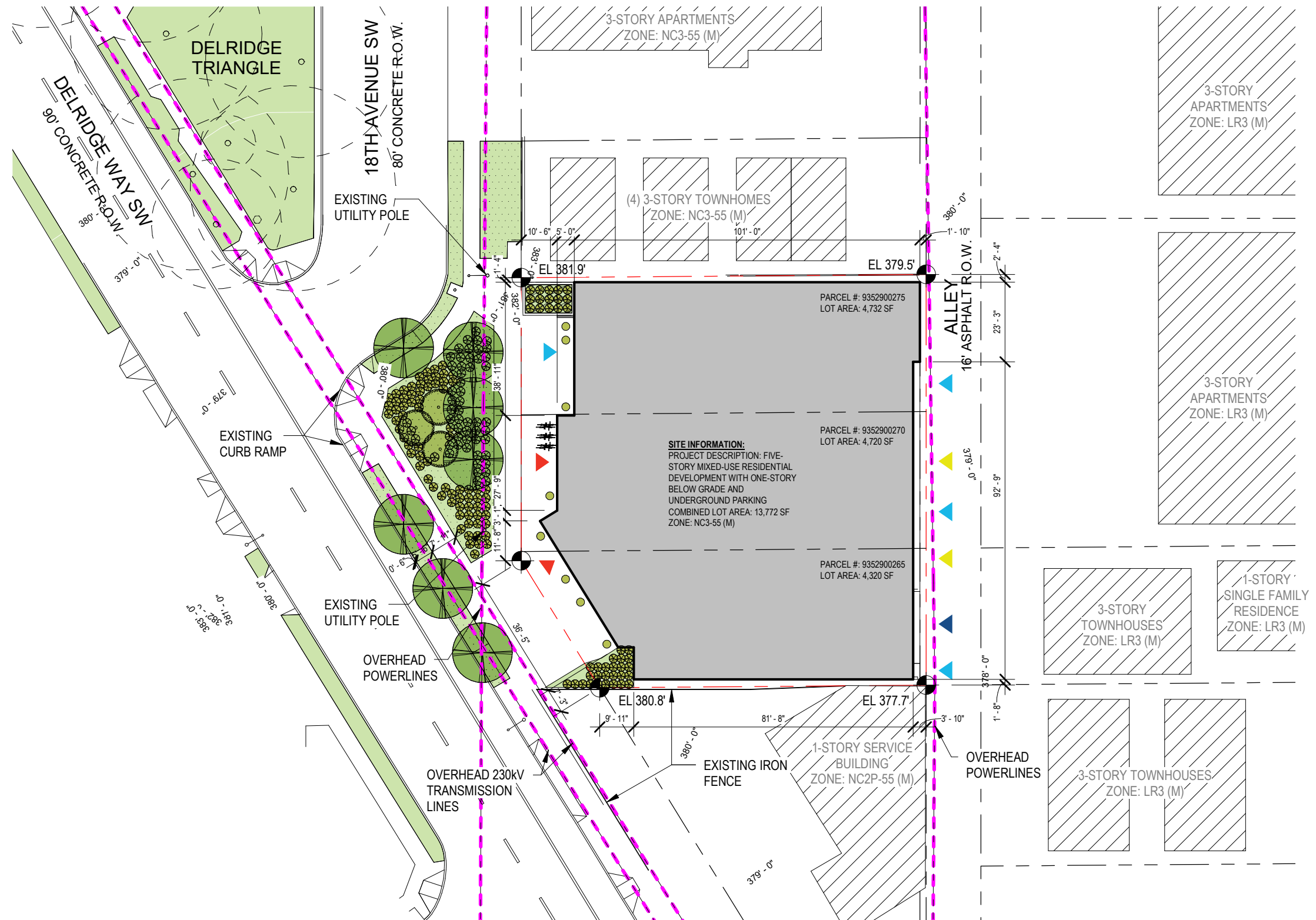

4.0 SITE PLAN WITH FUTURE DEVELOPMENT

- KEY**
- Landscape Area
 - ▶ Commercial Access
 - ▶ Residential Access
 - ▶ Trash Access
 - ▶ Vehicular Access
 - Overhead Powerlines

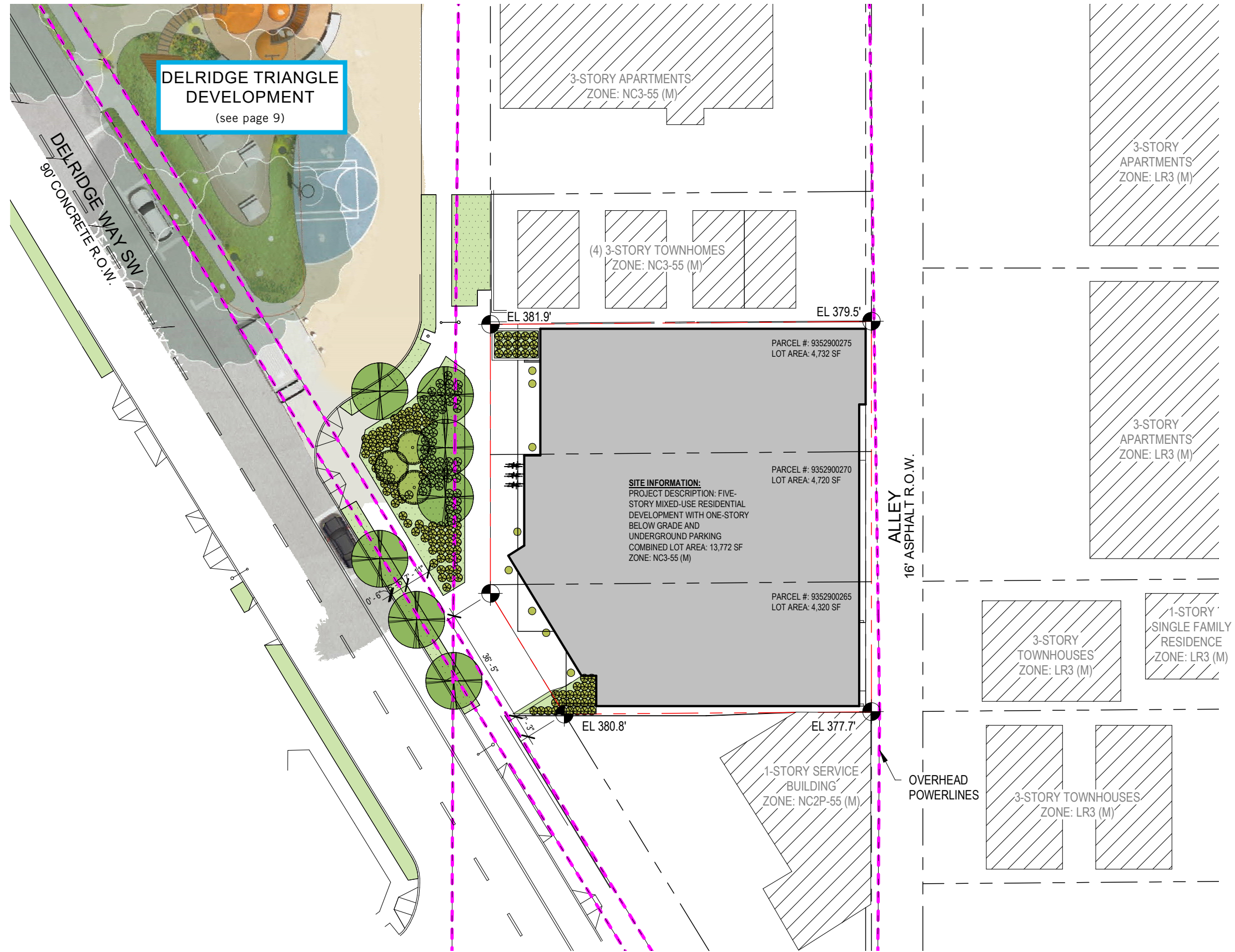

4.0 FUTURE DELRIDGE TRIANGLE DEVELOPMENT

DELRIDGE TRIANGLE DEVELOPMENT

The Delridge Triangle is the plot of land located west of the site across 18th Ave SW. It is currently the property of SDOT, but plans have been made by members of the neighborhood to push for Seattle's Parks and Recreation administration to purchase the land and revitalize it as Seattle's newest park. The imagery shown here was created by a consulting firm (Makers) for the Friends of the Delridge Triangle, a local committee, and was provided to us to show how the Triangle could look after redevelopment. This is only shown as a reference and the project team will coordinate with SDOT if the Delridge Triangle development progresses.

1

FINAL CONCEPT DESIGN

After the second community workshop the design team pulled together the key take a ways from what was seen as most beneficial components from each initial concept and developed the final plan which you see on this page.

The community wanted there to be a highly open activated space for both young children, teens, and adults that embraced the mature canopy on site. In response the plan calls for a central children's playspace positioned in the most protected and visible portion of the site integrated with the trees as well as a half basket all court and garden area. The community also was very drawn to the idea of a performance space so the basketball court was positioned in a way that it could be utilized for gathering.

The community also wanted a lot of seating in numerous configurations that both served parents coming to the site with their children as well as passive users of the site and those who wanted to watch basketball games. Seating was therefore situated in a variety of ways, around the children's play area which also acts as a safety perimeter, across from the basketball hoops and within the Pin Oaks for picnics.

Lastly users wanted the space to feel lush yet multi-functional, so the south end of the site was further developed into a garden space with the center area retaining its hardscape for a variety of play and versatility. To this end there are also two dedicated pull out spaces defined in the plan that could be reserved for food trucks or for load in and out space for activations. Both spaces could remain in SDOT prevue or, be included in the park site if The Parks Department has a management agreement for the site in the future.



PROPOSED DELRIDGE TRIANGLE DESIGN (SLIDE PROVIDED BY MAKERS)

4.0 FUTURE DELRIDGE WAY SW DEVELOPMENT

DELRIDGE WAY SW DEVELOPMENT

SDOT also has separate plans to make street improvements along Delridge Way SW which include adding a dedicated bike lane and a transit island west of the site. SDOT began construction on this project in June 2020 and plans to be finished sometime in 2022.

2

APPENDIX A. RAPIDRIDE DELRIDGE IMPROVEMENTS

Seattle Department of Transportation (SDOT) is planning street improvements and rechannelization on Delridge Way in conjunction with King County Metro's project to upgrade Route 120 to the new RapidRide H Line. These street improvements include repaving, bus lanes, bike lanes, new bus stops, landscaping, sidewalks and concrete driveway replacements. The entire length of Delridge Way within Seattle city limits is included in this program, including areas that will not be served by RapidRide H. RapidRide H will leave Delridge Way at SW Barton Pl to serve the Westwood area before continuing south through White Center.

As of July, 2019, planning for these improvements is still underway. Thirty percent designs were presented to the public in May, depicting a new protected bike lane and removal of street parking on the southbound side of Delridge Way. A new "island" bus stop for routes 60 and 128 will be constructed opposite the triangle, between the bike and traffic lanes. These are draft designs that will continue to change as the planning process moves forward. Construction is expected to begin in early 2020; Rapidride service is scheduled to begin in 2021.



30% Street Design Channelization Plan



30% Street Design Paving Plan

4.0 LANDSCAPE PLAN

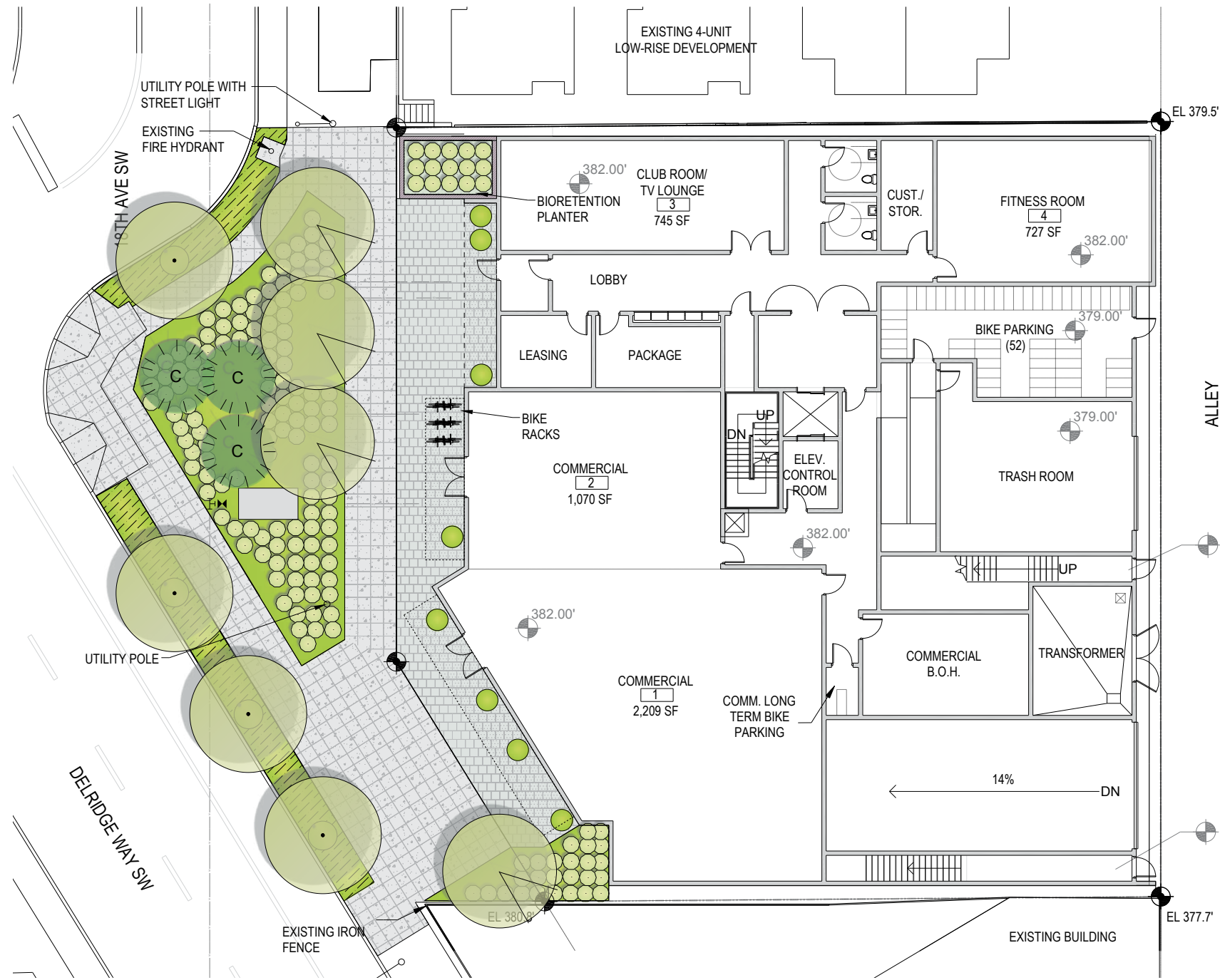

LEVEL 1

PLANT SCHEDULE

QUANT	BOTANICAL NAME	COMMON NAME	SIZE
3	SMALL TREE		1.5" CAL
4	SMALL TREE STREET TREE FORM		2-2.5" CAL
4	SMALL TREE STREET TREE FORM		2-2.5" CAL
3	MEDIUM EVERGREEN TREE		6-7'
* 218 #	SHRUB WITH MATURE HEIGHT OF AT LEAST 24"		2 GAL
	PLANTING AREA, TYPICAL		
	GREEN ROOF PLANTING		
	BIORETENTION PLANTER		

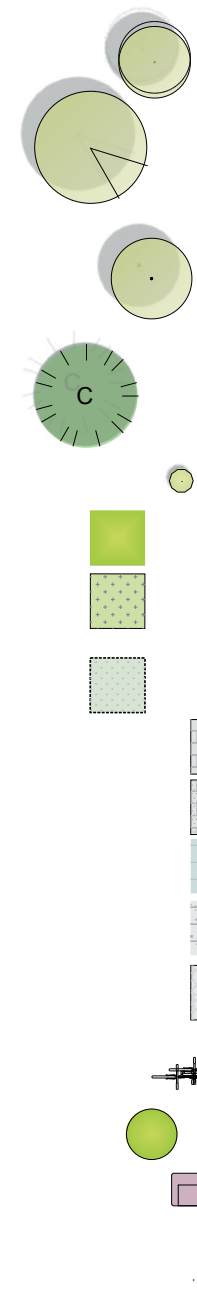

- PERVIOUS PAVING, WITH A TOTAL OF OVER 24" OF GRAVEL AND SOIL BENEATH, MUST MEET SEATTLE PUBLIC UTILITIES DEFINITION OF PERMEABLE PAVING
- CONCRETE PAVING OR PAVERS UNDER OVERHANG, NOT COUNTED IN GREEN FACTOR
- PAVERS ON PEDESTALS
- CONCRETE PAVING, WITH STANDARD 24" BY 24" SCORING
- 7/8" WASHED ROUNDED GRAVEL
- CITY OF SEATTLE STANDARD LOOP BIKE RACK (5), TOTAL CAPACITY EQUALS 10 BIKES
- TOURNESOL WILSHIRE PLANTER, 24" DEPTH, COORDINATE FINISH AND COLOR WITH OWNER AND LA
- GAS GRILL AND WORK STATION
- GAS FIRE PIT
- GREEN SCREEN METAL LATTICE, SEE GREEN FACTOR EXHIBIT SHEETS FOR WIDTH BY HEIGHT DIMENSIONS



4.0 LANDSCAPE PLAN



PLANT SCHEDULE

QUANT	BOTANICAL NAME	COMMON NAME	SIZE
3	SMALL TREE		1.5" CAL
4	SMALL TREE STREET TREE FORM		2-2.5" CAL
4	SMALL TREE STREET TREE FORM		2-2.5" CAL
3	MEDIUM EVERGREEN TREE		6-7'
* 218 #	SHRUB WITH MATURE HEIGHT OF AT LEAST 24"		2 GAL
	PLANTING AREA, TYPICAL		
	GREEN ROOF PLANTING		
	BIORETENTION PLANTER		

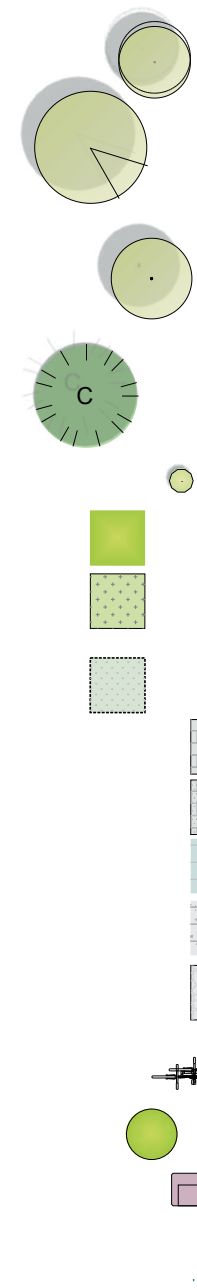

- PERVIOUS PAVING, WITH A TOTAL OF OVER 24" OF GRAVEL AND SOIL BENEATH, MUST MEET SEATTLE PUBLIC UTILITIES DEFINITION OF PERMEABLE PAVING
- CONCRETE PAVING OR PAVERS UNDER OVERHANG, NOT COUNTED IN GREEN FACTOR
- PAVERS ON PEDESTALS
- CONCRETE PAVING, WITH STANDARD 24" BY 24" SCORING
- 7/8" WASHED ROUNDED GRAVEL
- CITY OF SEATTLE STANDARD LOOP BIKE RACK (5), TOTAL CAPACITY EQUALS 10 BIKES
- TOURNESOL WILSHIRE PLANTER, 24" DEPTH, COORDINATE FINISH AND COLOR WITH OWNER AND LA
- GAS GRILL AND WORK STATION
- GAS FIRE PIT
- GREEN SCREEN METAL LATTICE, SEE GREEN FACTOR EXHIBIT SHEETS FOR WIDTH BY HEIGHT DIMENSIONS

LEVEL 2



4.0 LANDSCAPE PLAN



ROOF

PLANT SCHEDULE

QUANT	BOTANICAL NAME	COMMON NAME	SIZE
3	SMALL TREE		1.5" CAL
4	SMALL TREE STREET TREE FORM		2-2.5" CAL
4	SMALL TREE STREET TREE FORM		2-2.5" CAL
3	MEDIUM EVERGREEN TREE		6-7'
* 218 #	SHRUB WITH MATURE HEIGHT OF AT LEAST 24"		2 GAL
	PLANTING AREA, TYPICAL		
	GREEN ROOF PLANTING		
	BIORETENTION PLANTER		

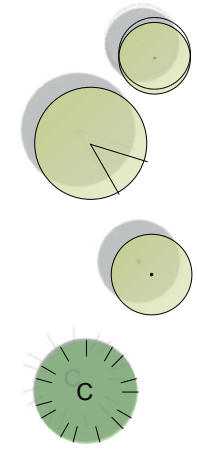

- PERVIOUS PAVING, WITH A TOTAL OF OVER 24" OF GRAVEL AND SOIL BENEATH, MUST MEET SEATTLE PUBLIC UTILITIES DEFINITION OF PERMEABLE PAVING
- CONCRETE PAVING OR PAVERS UNDER OVERHANG, NOT COUNTED IN GREEN FACTOR
- PAVERS ON PEDESTALS
- CONCRETE PAVING, WITH STANDARD 24" BY 24" SCORING
- 7/8" WASHED ROUNDED GRAVEL
- CITY OF SEATTLE STANDARD LOOP BIKE RACK (5), TOTAL CAPACITY EQUALS 10 BIKES
- Tournesol Wilshire Planter, 24" depth, coordinate finish and color with owner and LA
- GAS GRILL AND WORK STATION
- GAS FIRE PIT
- GREEN SCREEN METAL LATTICE, SEE GREEN FACTOR EXHIBIT SHEETS FOR WIDTH BY HEIGHT DIMENSIONS



5.0 URBAN DESIGN ANALYSIS

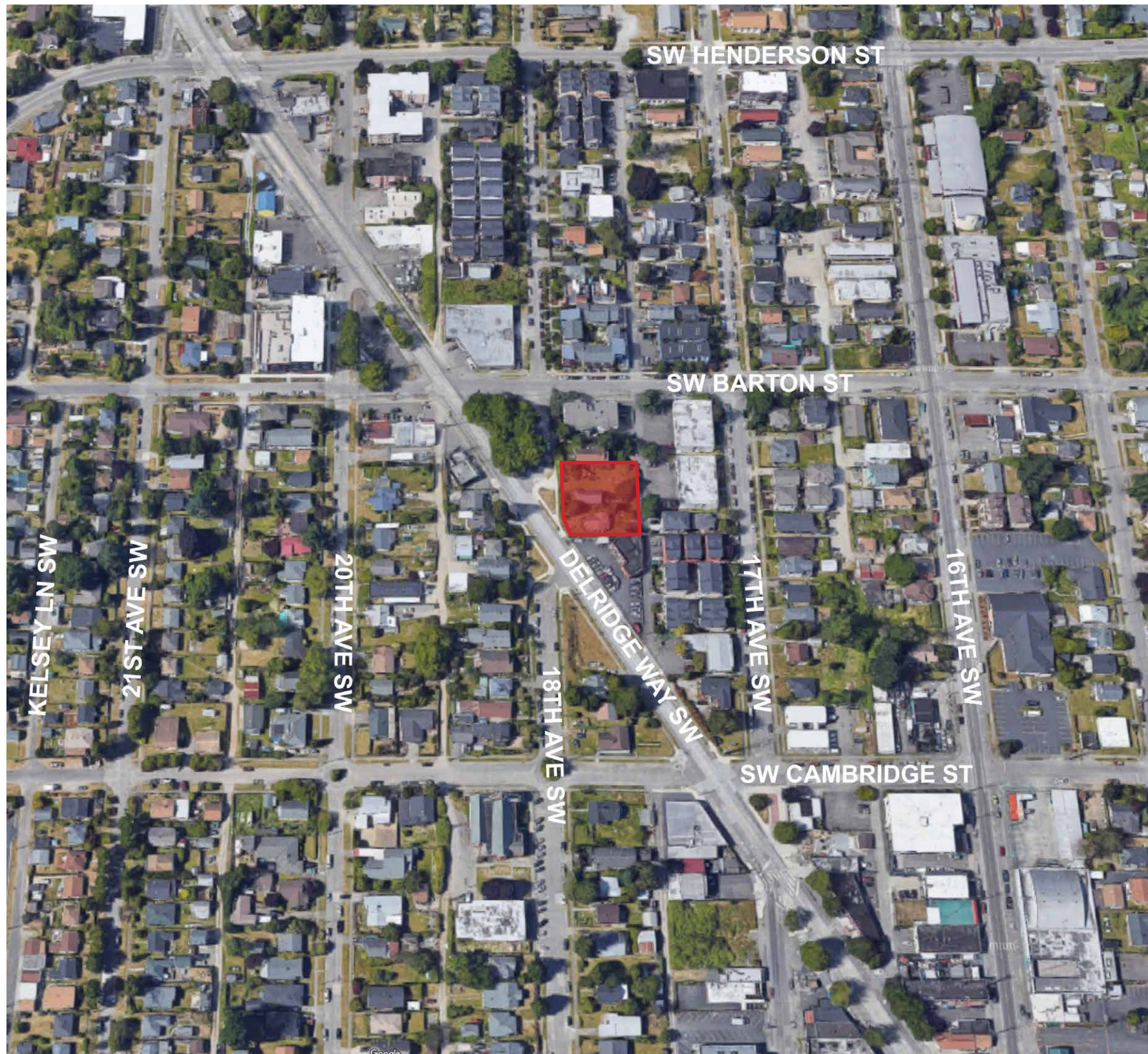

AXONOMETRIC MAP (GOOGLE EARTH)

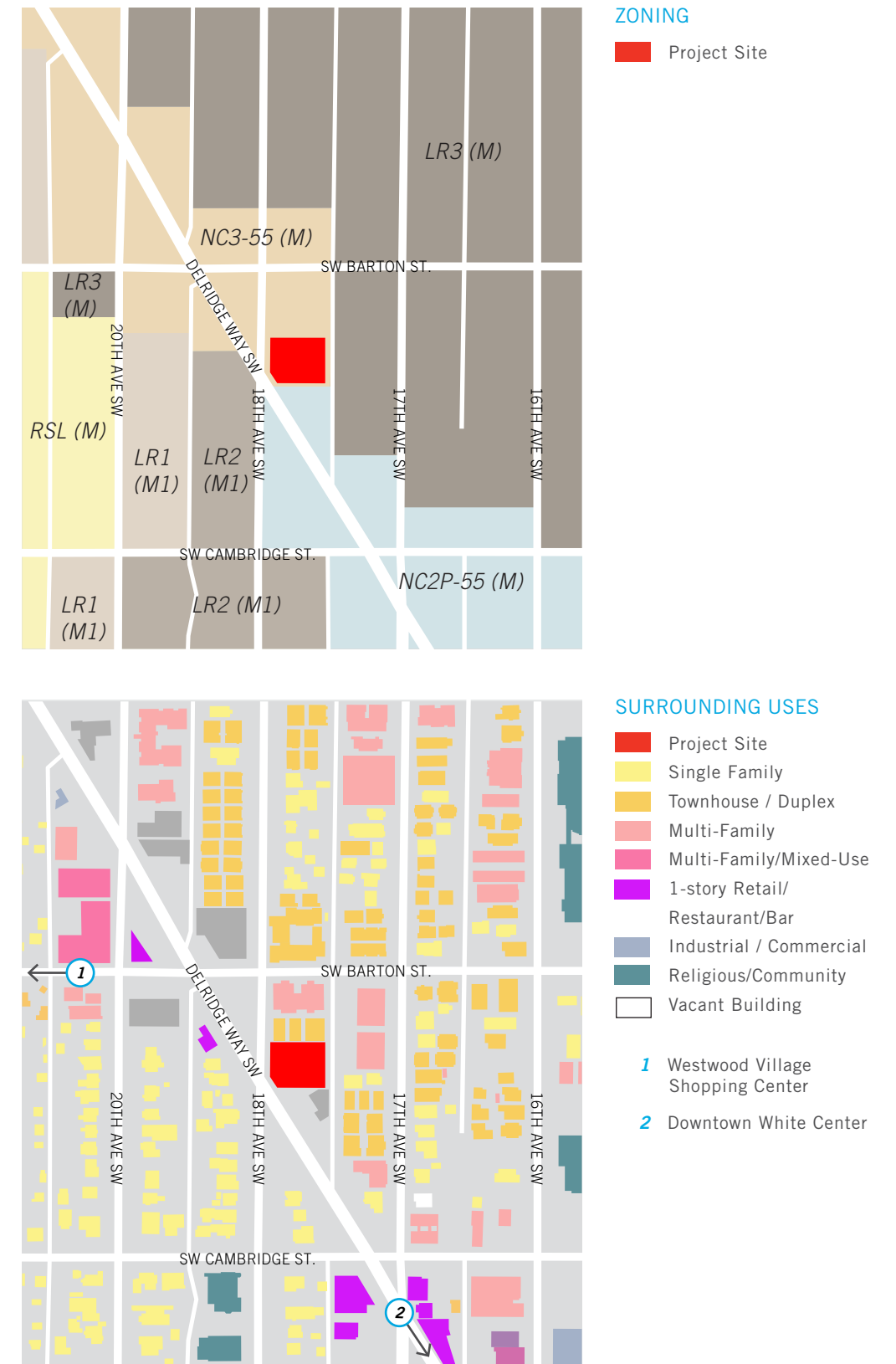

5.0 URBAN DESIGN ANALYSIS

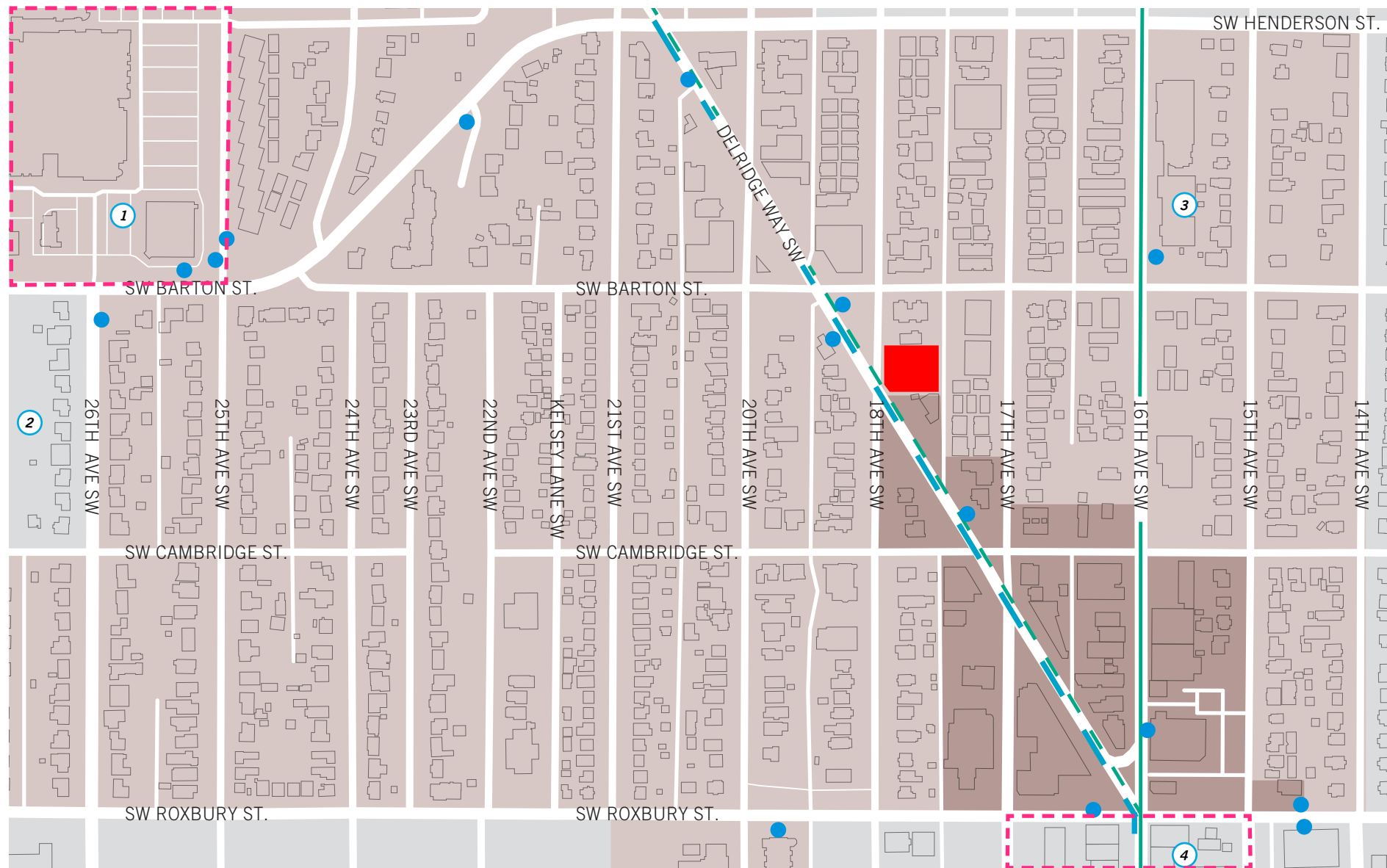

VICINITY MAP KEY

- Project Site
- Westwood-Highland Park (Residential Urban Village)
- Pedestrian Designated Zone
- Dedicated Bike Lanes
- Bike & Car Lane shared
- Future Rapid Ride Bus Line 'H'
- Bus Stops
- View (Images Below)
- Shopping/ Retail/ Restaurant/ Area

COMMUNITY NODES & LANDMARKS



1 WESTWOOD VILLAGE
0.6 MILES FROM SITE



2 ROXHILL PARK
0.7 MILES FROM SITE



3 SALVATION ARMY COMMUNITY CENTER
0.2 MILES FROM SITE



4 DOWNTOWN WHITE CENTER
0.4 MILES FROM SITE

5.0 URBAN DESIGN ANALYSIS

PROPOSED AND NEW DEVELOPMENTS

The Delridge community is seeing a number of new multifamily residential projects proposed with modern aesthetics and amenities. Such projects are also larger in scale than previous developments due to the city's drive for densification, a scale in which the proposed design will fit well as the neighborhood evolves.

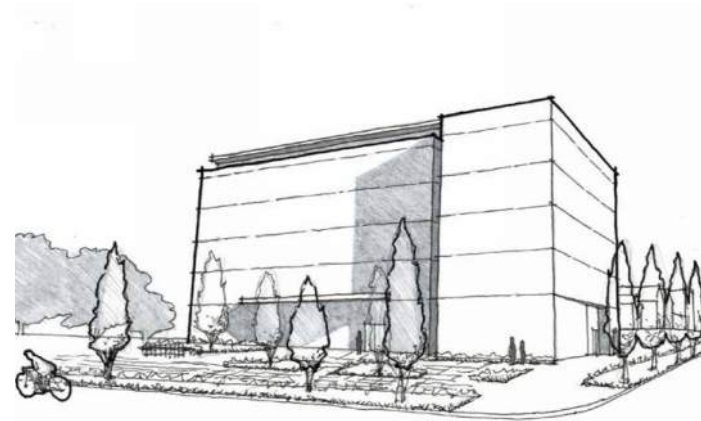

1 9201 DELRIDGE WAY SW
SDCI# 3036618



2 9043 18TH AVENUE SW
SDCI# 3020870



3 9021 17TH AVENUE SW
SDCI# 3020808



4 9217-9229 16TH AVENUE SW
SDCI# 3025717, 3026206,



5 9049 20TH AVE SW
SDCI# 3026801



6 BLUE STONE APARTMENTS 9051 20TH AVE



7 RESIDENTIAL DEVELOPMENT 9200 18TH AVE SW

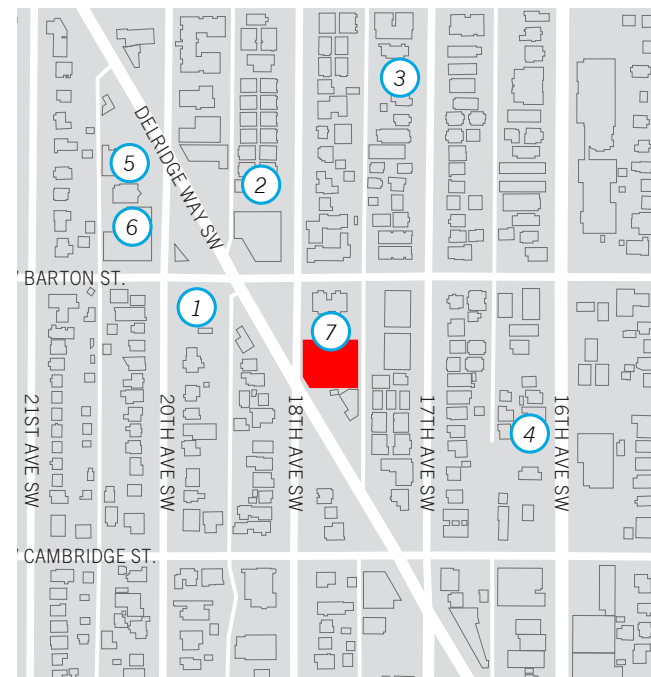

MAP KEY

- Project Site
- ⓘ View



5.0 URBAN DESIGN ANALYSIS

STREETSCAPES

1 18TH AVE SW LOOKING WEST

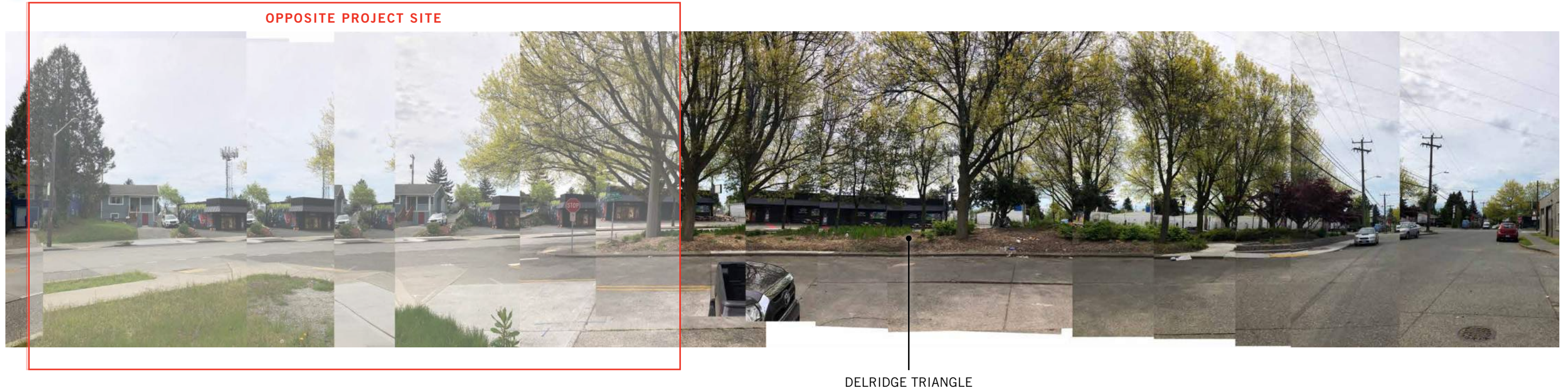

2 18TH AVE SW LOOKING EAST

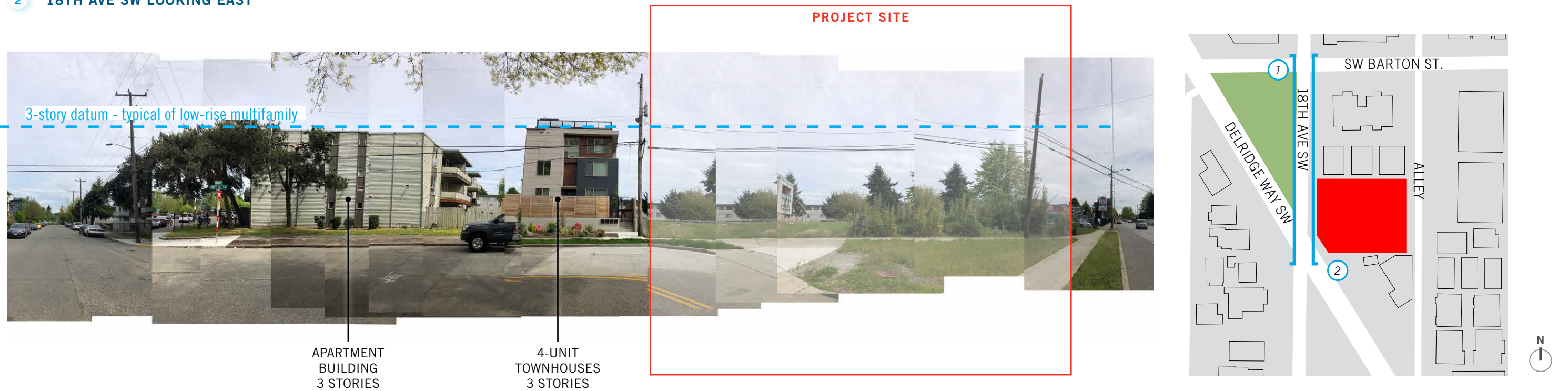

5.0 URBAN DESIGN ANALYSIS

STREETSCAPES

3 ALLEY LOOKING WEST



4 ALLEY LOOKING EAST

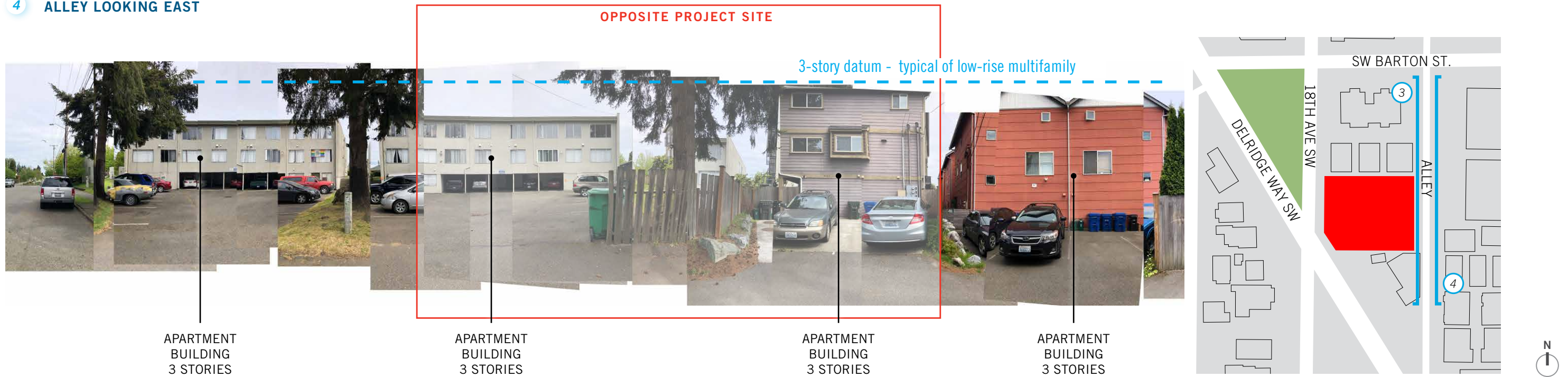

5.0 URBAN DESIGN ANALYSIS

STREETSCAPES

1 DELRIDGE WAY SW LOOKING WEST



2 DELRIDGE WAY SW LOOKING EAST

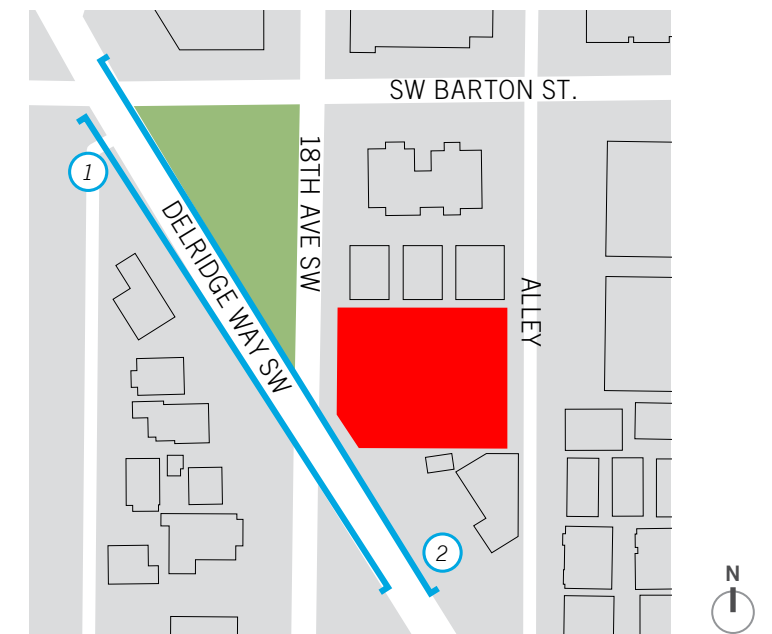

5.0 URBAN DESIGN ANALYSIS

SITE PHOTOS

The following photos show the site's existing conditions and surrounding context. The site previously held single family residences, which has since been removed. The site slopes roughly 3.5' from the northwest to southeast with the northwest corner of the site the highest portion. The alley sits lower in elevation than 18th Ave SW and had been improved so no alley improvement or widening is required.

Overhead powerlines can be seen running along 18th Ave SW and the alley and Transmission Lines along Delridge Way SW and will have an impact on the proposed design in the form of setbacks. To the south of the site is an auto repair building with a chainlink fence against the property line. To the north of the site are four new townhouses which sit approximately 5'-0" from the property line and have parking along the alley. All trees onsite will be removed for construction. No street trees are currently present but are recommended along 18th Ave SW per SDOT standards.



1 LOOKING NORTH ON 18TH AVE SW



2 LOOKING NORTHEAST ACROSS DELRIDGE WAY SW

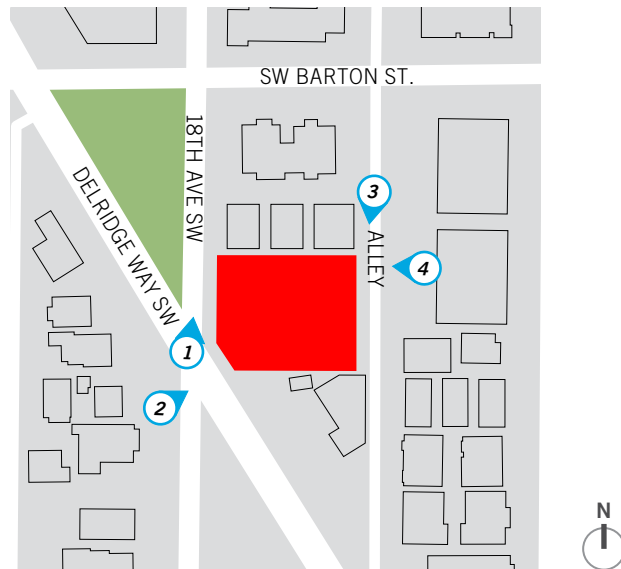

MAP KEY

- Project Site
- 📍 View



3 LOOKING SOUTH AT EAST LOT LINE IN ALLEY



4 LOOKING WEST ALONG NORTH LOT LINE

5.0 URBAN DESIGN ANALYSIS

DESIGN NARRATIVE

This building will be an anchor of this intersection, convergence of two different streets - where a rigid street grid got intersected by Delridge Way SW. The design will respond to the different characters of the two streets - Delridge Way SW and 18th Ave SW. The design will reflect the challenge of preserving the established residential character of the neighborhood while integrating a more contemporary presence that is shaping Delridge Way. It will also respond to the existing Delridge Triangle.

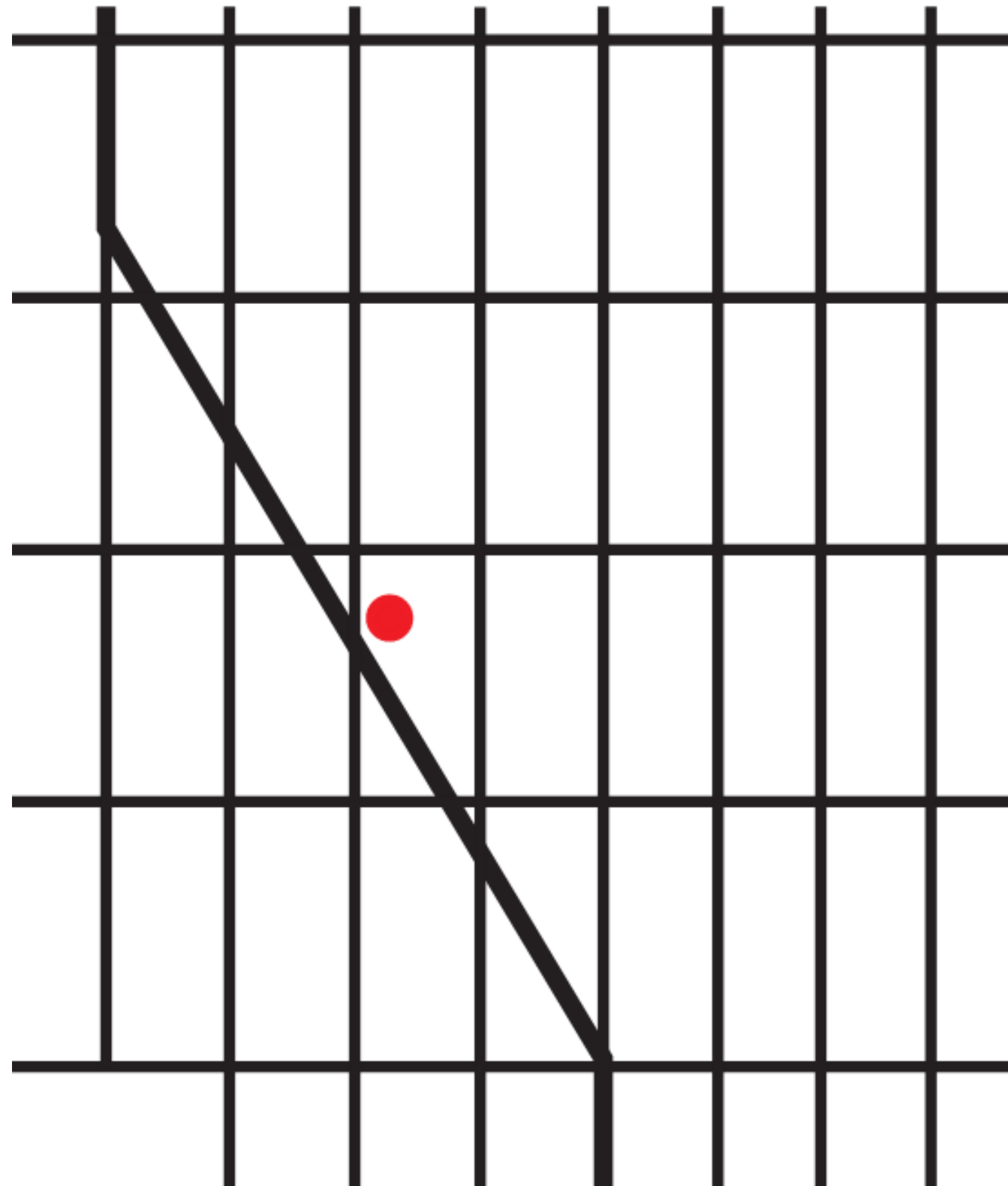

INTERSECTING GRID &
DIFFERENT STREET CHARACTERS

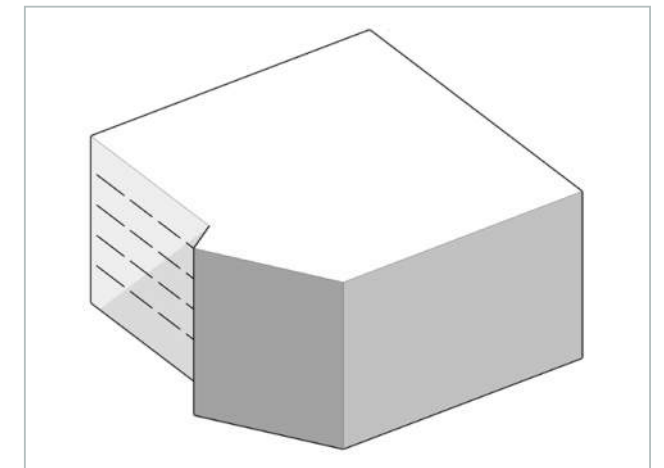

INTERSECTING MASSES



DIFFERENT FACADE TREATMENTS

5.0 URBAN DESIGN ANALYSIS

NEIGHBORHOOD PATTERN

Neighborhood development pattern is defined by intersection of diagonally platted Delridge Way SW with regular orthogonal grid, creating triangular sites and intersections. Due to prevailing nature and character of recent development of this condition, continuous street facade and development will likely not occur in this neighborhood.

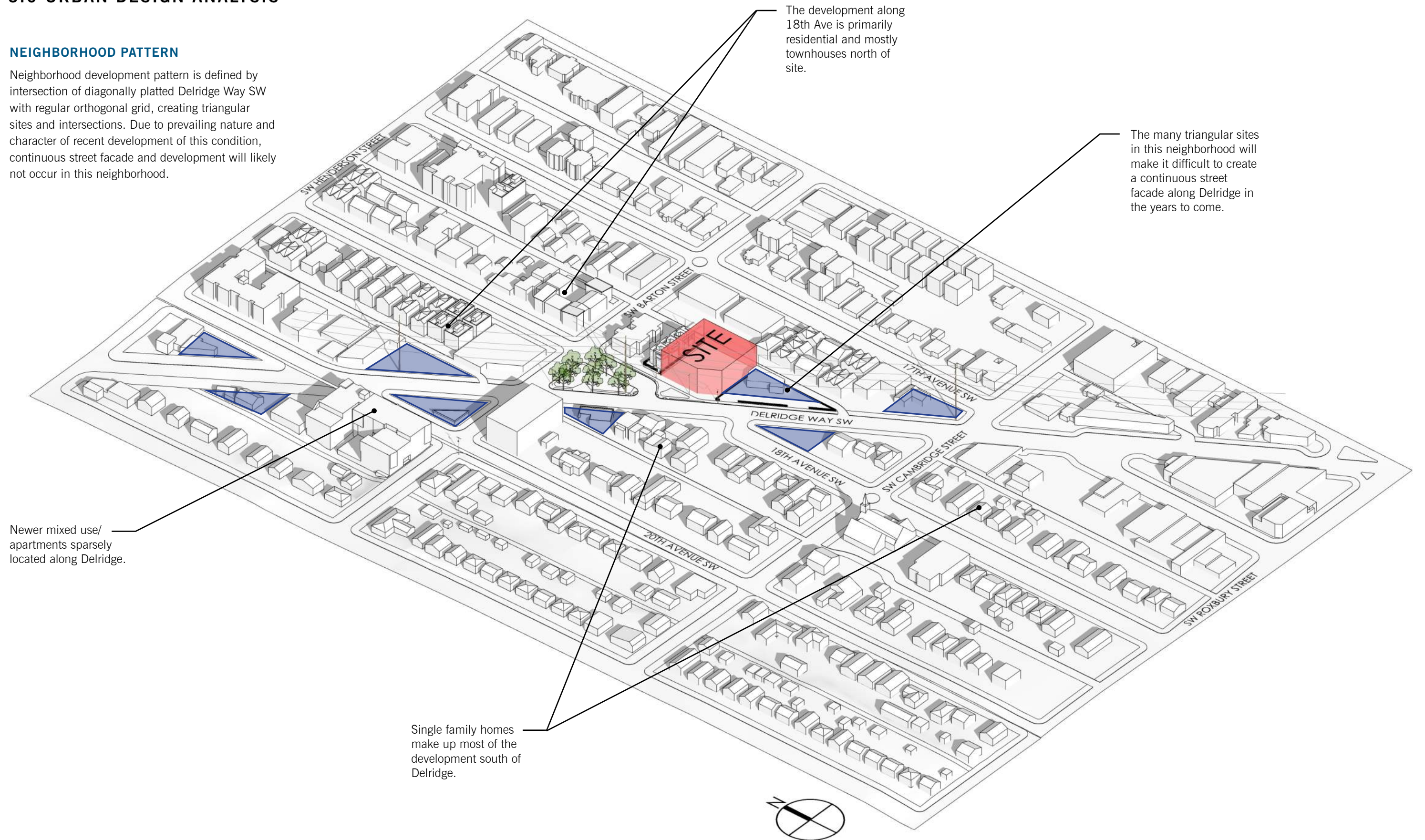

Newer mixed use/
apartments sparsely
located along Delridge.

Single family homes
make up most of the
development south of
Delridge.

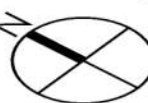

5.0 URBAN DESIGN ANALYSIS

IMMEDIATE CONTEXT

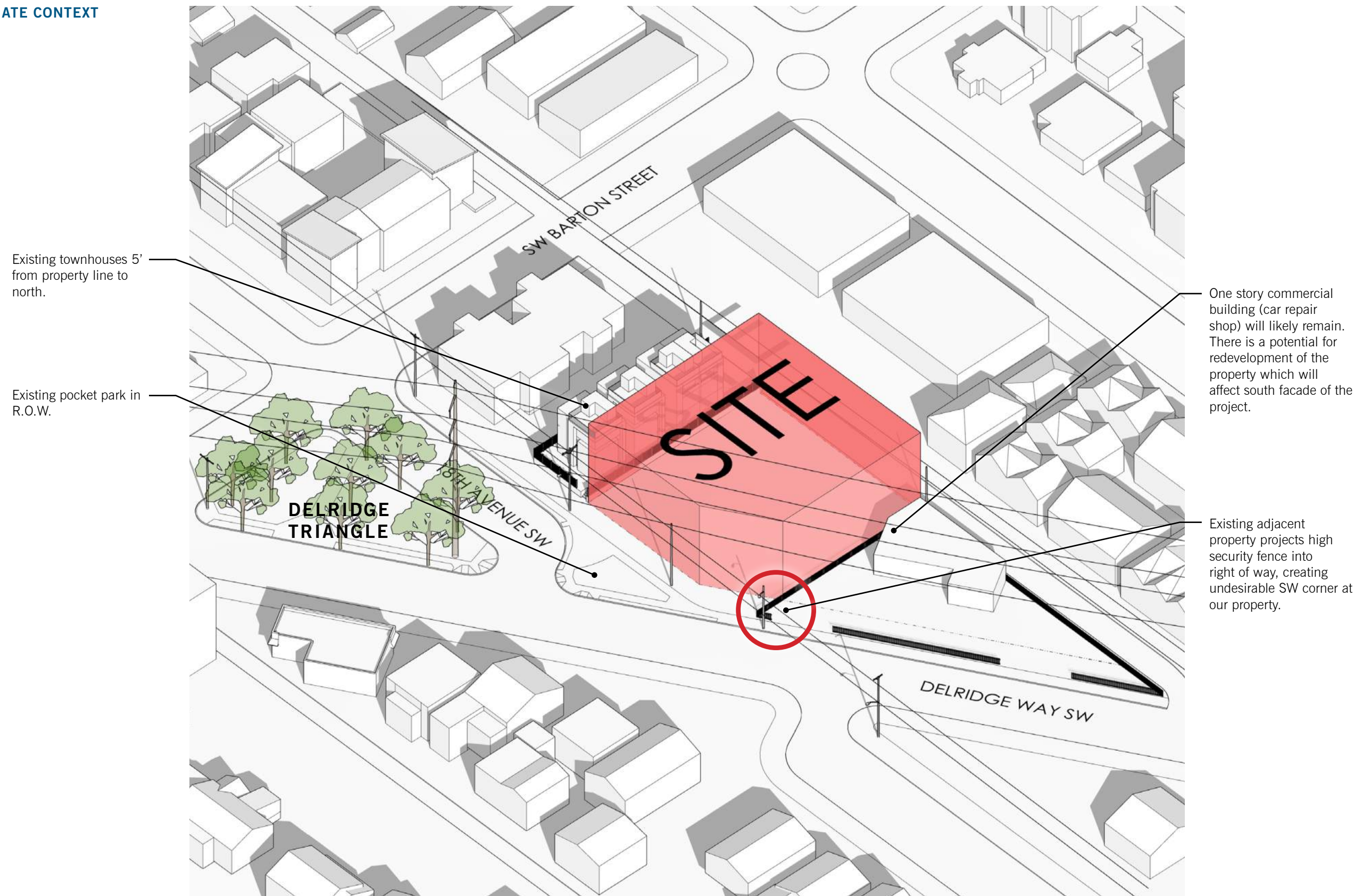

5.0 URBAN DESIGN ANALYSIS

SITE CONSTRAINTS:

High voltage powerlines require setbacks both on 18th Avenue SW, Delridge Way SW, and along the alley.

KEY

Overhead Powerlines

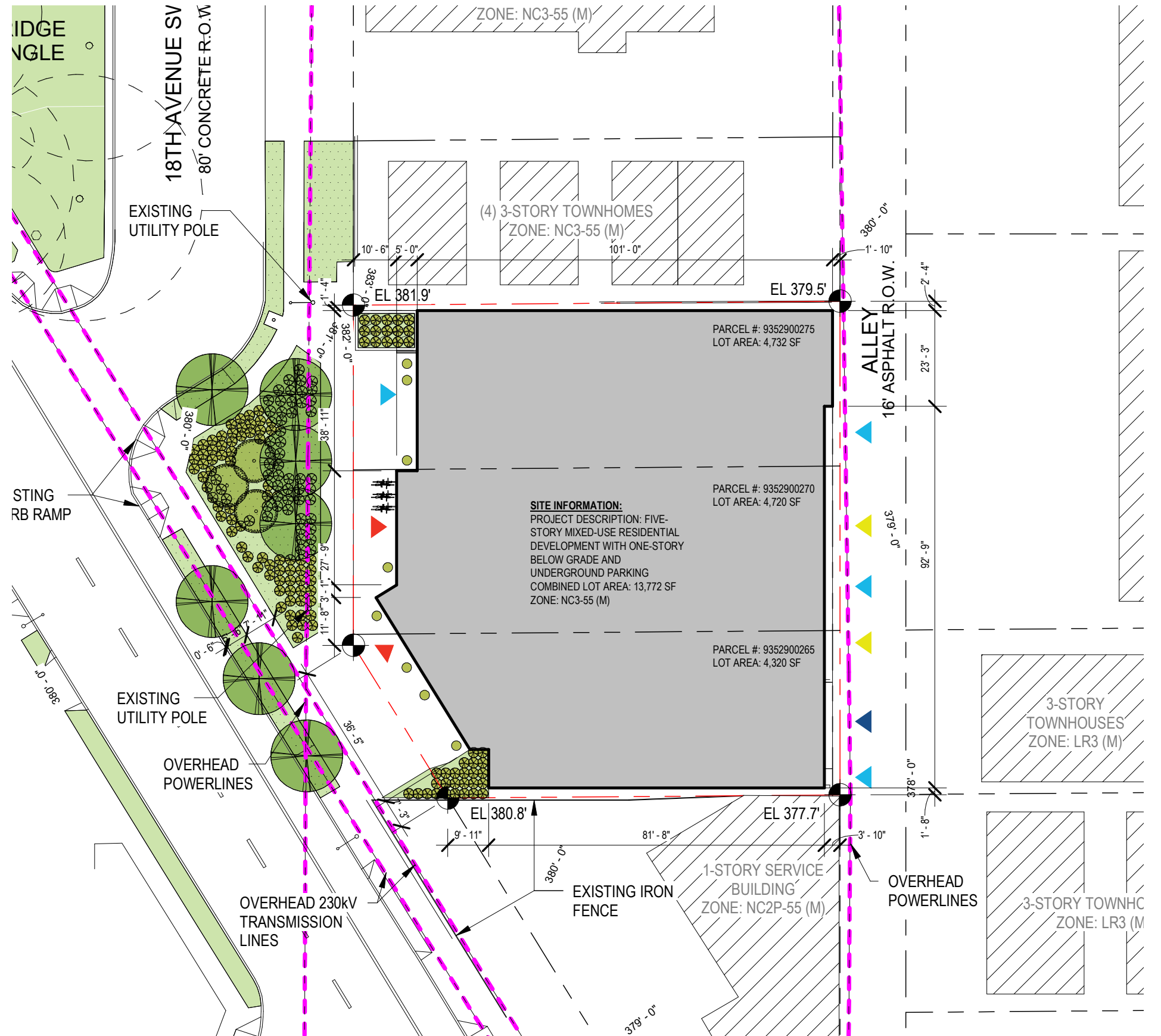
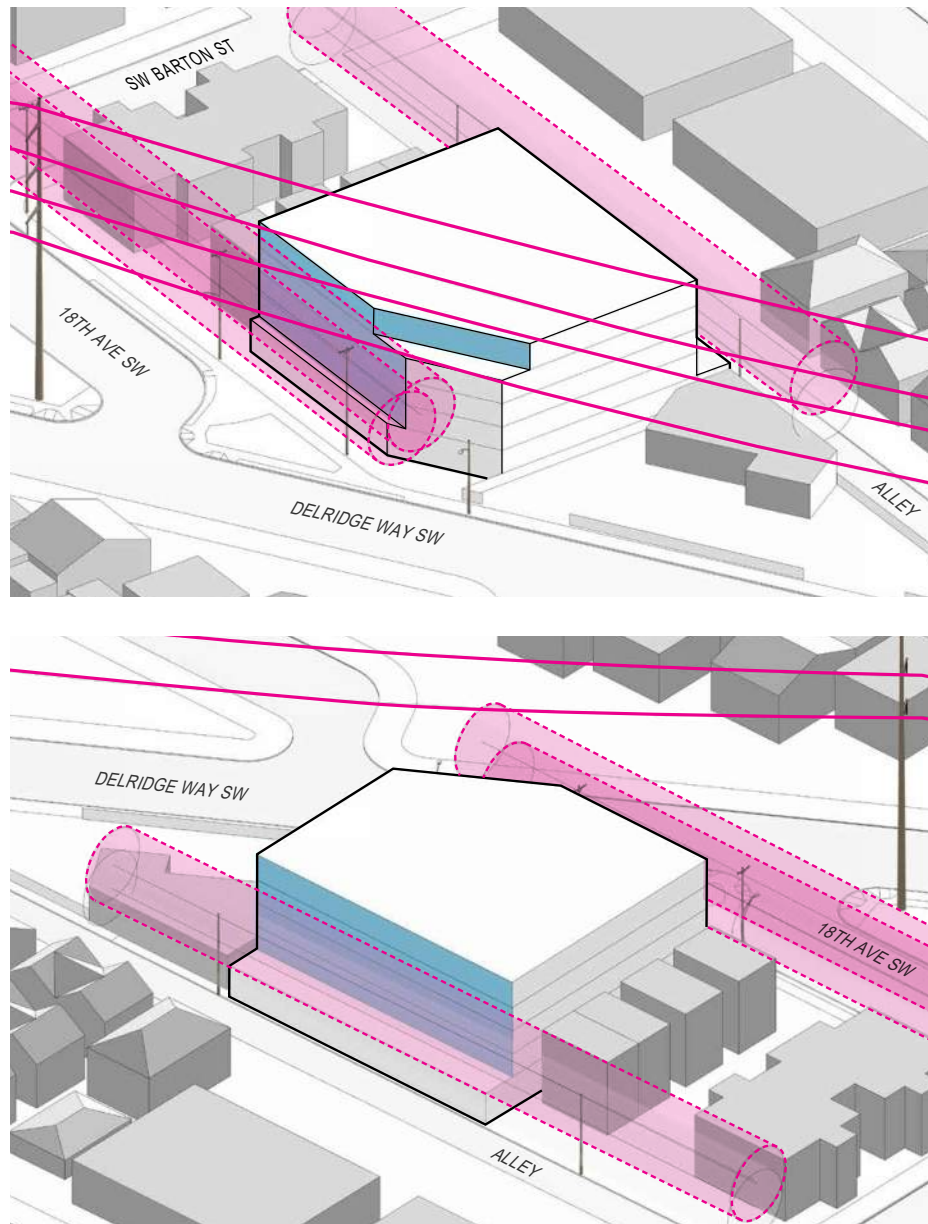

6.0 ZONING DATA

ZONE: NC3-55 (M)

URBAN VILLAGE: WESTWOOD-HIGHLAND PARK RESIDENTIAL

APPLICABLE ZONING	SMC-SECTION	SUB-SECTION	REQUIREMENT	OPTION 4	OPTION 5 (PREFERRED)
Uses Permitted	23.47A.004	Table A	Eating and Drinking Establishments, Office, Sales and Service, Live Work Units, Residential Uses, Lodging: Permitted	√	√
Street-Level Development Standards	23.47A.008	A.1	Applies for structures in NC-zones	√	√
		A.2.b	Blank street facing facades between 2 feet & 8 feet above sidewalk shall not be more than 20 feet in length	√	√
		A.2.c	Total blank facades shall not exceed 40% of the width of the street facing facade of the structure	√	√
		A.3	Street level, street facing facades shall be within 10 of the street property line, unless wider sidewalks, plazas, or other approved spaces are provided.	√	√
		B.2.a	60% of street facing facades between 2 feet & 8 above sidewalk feet shall be transparent	√	√
		B.3.a	Non-residential uses > 600 SF shall extend an average depth of at least 30 feet and a minimum depth of 15 feet from the street-level street-facing facade	√	√
		B.4	Non-residential uses at street level shall have a floor-to-floor height of at least 13 feet	√	√
Structure Height	23.47A.012	A	55 feet max height limit	√	√
Floor Area Ratio	23.47A.013	Table A	FAR limit outside Station Area Overlay District: 3.75	√	√
Landscaping	23.47A.016	A.2	Green factor of 0.3 required	√	√
		B.1	Street Trees are required	√	√
Light and Glare Standards	23.47A.022	A	Exterior lighting must be shielded and directed away from adjacent uses	√	√
		B	Interior lighting in parking garages must be shielded to minimize nighttime glare affecting nearby uses	√	√
Amenity Area	23.47A.024	A	Amenity areas are required in an amount equal to 5 percent of the total gross floor area in residential use, except as otherwise specifically provided in this Chapter 23.47A.	√	√
		B	All residents shall have access to at least one common or private amenity area. Amenity areas shall not be enclosed. Common amenity area shall have a minimum horizontal dimension of 10 feet, and be no less than 250 SF. Private balconies and decks shall have a minimum area of 60 SF and no horizontal dimension less than 6 feet.	√	√
Required Parking	23.54.015	Table A, K	Non-residential uses in urban villages that are not within an urban center or the Station Area Overlay District, if the non-residential use is located within a frequent transit service area. = No minimum requirement	√	√
		Table B, M	All residential uses in commercial, RSL and multifamily zones within urban villages that are not within urban center or the Station Area Overlay District, if the residential use is located within a frequent transit service area. = No minimum requirement	√	√
Required Bicycle Parking	23.54.015	Table D, A.1, A.6, D.2	Eating and drinking establishments: Long-term = 1 per 5,000 sf, Short-term = 1 per 1,000 sf (Required spaces: 1 long-term, 4 short-term); or General Sales: Long Term = 1 per 4,000 sf, Short-term = 1 per 2,000sf (Required spaces: 1 long-term, 2 short-term;) Provided spaces: 1 long-term, 4 short-term) Multi-family structures: Long-term = 1 per dwelling unit, Short-term = 1 per 20 dwelling units (Required spaces: 56 long-term, 3 short-term; Provided spaces: 56 long-term, 6 short-term [Option 5])	√	√
Trash Storage	23.54.040	Table A	Residential development: 51-100 dwelling units = Minimum of 375 sf + 4 sf for each additional unit above 50 = 499 sf Non-residential development: (3,280 sf provided) 0-5,000 sf = Minimum of 82sf, but 50% = 41sf (see B below) [Total minimum required: 540 sf; Provided: 720 sf (Option 5)]	√	√
		B	Mixed use development that contains both residential and non-residential uses shall meet the storage space requirements shown in Table A for 23.54.040 for residential development, plus 50 percent of the requirement for non-residential development. In mixed use developments, storage space for garbage may be shared between residential and non-residential uses, but separate spaces for recycling shall be provided.	√	√

7.0 DESIGN GUIDELINES

CS1-B SUNLIGHT AND NATURAL VENTILATION

Architect Response:

- A 10'-15' setback proposed for approximately two-thirds of the total north facade length minimizes shading and solar exposure impact on the neighboring townhouses.
- An 11.5' setback provided for approximately one-half of the total south facade length permits openings on the facade, providing natural light into units.

CS2-B ADJACENT SITES, STREETS, AND OPEN SPACES

Architect Response:

- The proposed building mass reflects the unique lot configuration and street intersection. It connects to both streets fronting the site in different ways as described in the response to CS2-C.
- New trees proposed along the two streets and at the existing bulb will add to the greenery that already exists across the site at Delridge Triangle. These two tree 'islands' will mark this intersection as pedestrians and cars travel north on 18th Ave SW.

CS2-C.1 RELATIONSHIP TO THE BLOCK - CORNER SITES

Architect Response:

- The proposed building is oriented toward Delridge, anchoring this prominent corner site. The Delridge mass – extended out to the street as far as the power line clearance allows - rises from the ground up, further emphasizing the corner. From there, the building turns gently to 18th Ave SW and the change in the facade treatment signals the change of the street character. While Delridge facade is strong and confident, the 18th Ave facade feels softer and residential-like.

CS2-D HEIGHT, BULK, AND SCALE

Architect Response:

- The site marks the beginning of the NC3 zone and the end of the NC2-Pedestrian zone south of site along Delridge Way SW, although the height limit for both zones remains the same at 55'. The LR-3 zone across the alley has the height limit of 50'. Given these height limits, the scale of the proposed development is in line with the anticipated zoning envelope in this area.
- Façade modulation and building setback are utilized to reduce a perceived mass, give some relief to the existing townhouses to the north, and provide solar gain to the units facing south. The limited number of openings proposed on the north facade are carefully placed to reduce privacy concern.

CS3 ARCHITECTURAL CONTEXT AND CHARACTER

Architect Response:

- The proposed building strives to both fit into an established residential neighborhood and integrate into a future development pattern along an evolving Delridge. This effort is achieved through the proposed massing, fenestration pattern, secondary architectural elements, and landscaping. The result is the building that serves both as an urban edge and is a compatible addition to the residential neighborhood.



ARCHITECTURAL CONTEXT AND CHARACTER



STREET-LEVEL INTERACTION

7.0 DESIGN GUIDELINES

PL3 STREET-LEVEL INTERACTION

Architect Response:

- Residential and retail entries are clearly defined and visible from streets. Retail spaces are located at the corner of Delridge Way SW and 18th Ave SW while a residential entry is located on 18th Ave SW. A recess in ground floor façade separates a residential entry from retail space.
- A generous setback provided at the street level widens the sidewalk and allows for retail activities to spill out. Planting and landscape features enliven this open space where future residents and retail patrons can mingle. The space also provides a respite from a busier Delridge, with a view of beautiful mature trees at Delridge Triangle. Ample glazing visually connects activities inside to outside.
- amenity space is tucked away from the busy Delridge Way and toward the neighboring residential buildings creating a quiet and safe entry for residents. Parking and back-of-house functions are located off the alley as is typical in this neighborhood.

DC2 ARCHITECTURAL CONCEPT

Architect Response:

- The proposed building mass reflects the unique lot configuration and street intersection. Even though the building facades aim to address the different characters of two streets fronting the site, they are designed as a whole. The building will possess both urban scale and human scale.
- Secondary elements such as balconies and canopies are provided to add visual interest, texture, and depth to the facades.
- Amount of blank wall has been minimized - reduced to one-third of the north façade length and one-half of the south façade length.



SECONDARY ELEMENTS ADD VISUAL INTEREST, TEXTURE, AND DEPTH TO FACADE

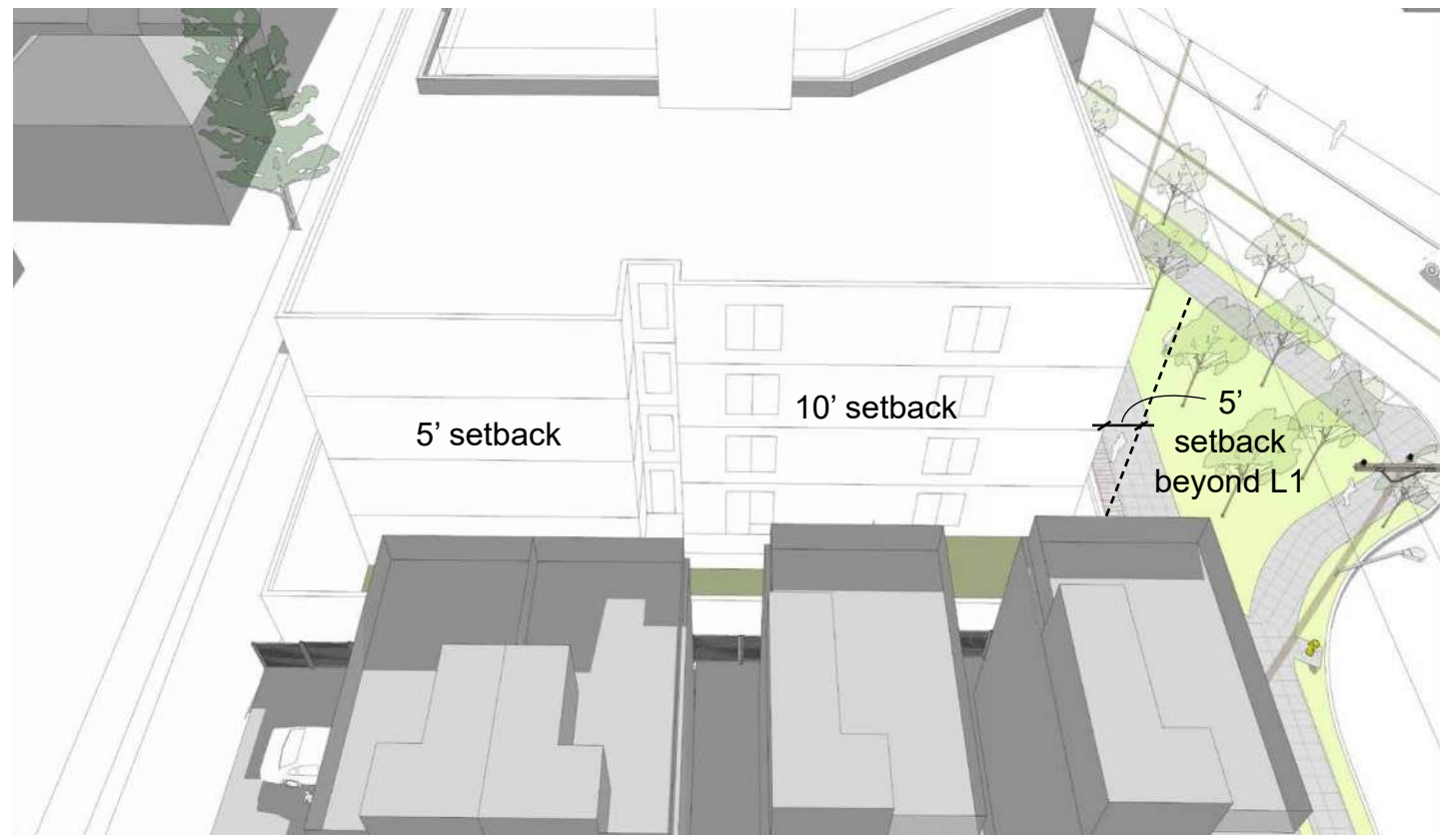

SETBACK ON NORTH FACADE GIVES RELIEF TO TOWNHOUSES TO NORTH

7.0 DESIGN GUIDELINES

ITEMIZED RESPONSE TO EDG 1

BOARD'S RECOMMENDATION:

1.a. The Board did not support moving forward with any of the three massing options presented, instead directing the applicant to return with additional massing options for consideration. Of the three presented, the Board found the most positive attributes in Option 1, which features a simpler massing that holds the corner of Delridge Way SW and 18th Avenue SW more effectively than the other options shown and provides better solar access. (CS1-B-2, CS2-B-2, CS2-C-1)

1.g. The Board observed that the proposal seems to be conflicted on whether to orient towards Delridge Way SW or 18th Avenue SW. The Board directed the applicant to create a strong urban edge on Delridge Way SW, including the upper levels. The Board was not supportive of the one-story massing at Delridge Way SW in the applicant's preferred scheme, encouraging a stronger presence at the corner instead. (CS2-B-2, CS2-C-1, CS3-A-4, DC2-A-1)



Option 4

RESPONSE: The continuous facade along 18th Ave SW and Delridge Way SW creates a balanced and strong 'Urban Edge' that reflects the grid shift. The north and south facades in contrast utilize setbacks to create a massing hierarchy.



Option 5 (Preferred)

RESPONSE: This option creates a strong 'Urban Edge' that holds the corner of Delridge Way SW and 18th Ave SW with a clear massing hierarchy. The mass along Delridge offers a strong 'Urban' presence that is balanced with the setback mass on 18th Ave, which reflects the residential street. Overall, the intersecting masses emphasizes the importance of the intersection.

7.0 DESIGN GUIDELINES

ITEMIZED RESPONSE TO EDG 1

BOARD'S RECOMMENDATION:

1.b. The Board discussed the applicant's preferred scheme (Option 3) extensively and described this option as too busy and perhaps trying too hard to relate to the adjacent townhouse development. The Board recommended simplifying the massing and reducing some of the ornamentation (e.g. frames) while cautioning the applicant not to overcorrect into a massing that is too flat or that completely disregards context. (CS3-A-4, DC2-A-1, DC2-B, DC2-C)



RESPONSE: This option is significantly simplified when compared to the previous preferred option. The facade along 18th ave SW and Delridge Way SW, although mostly flat, will have secondary elements such as balconies and material changes to create interest. The setbacks also allow for natural light and air to reach the adjacent neighbors.



RESPONSE: This is a simplified and more refined option compared to the previous preferred option. Differing massing treatments along Delridge Way SW and 18th Ave SW are further emphasized with setbacks along the north and south property lines. Secondary elements such as balconies and material changes would create interest for all facades and develop an overall hierarchy. The simplicity of the option acknowledges and respects the context in a successful way.

7.0 DESIGN GUIDELINES

ITEMIZED RESPONSE TO EDG 1

BOARD'S RECOMMENDATION:

1.c. The Board discussed the proposal's attempts to relate to the townhomes north of the site and observed that this design direction seemed to be the source of some of the less harmonious aspects of the design. The Board recommended instead that the applicant plan for and embrace the future context of Delridge Way SW, which is likely to consist of many large-scale multi-family buildings and a more urban context. (CS3-A-4)



Option 4

RESPONSE: Although the site to the south is unlikely to be fully developed, due to its irregular triangle shape, this option does account for the potential of a building being developed. The continuous facade along 18th Ave SW and Delridge Way SW creates a balanced and strong 'Urban Edge' that reflects the grid shift and the future context of the site.



Option 5 (Preferred)

RESPONSE: Although the site to the south is unlikely to be fully developed, due to its irregular triangle shape, this option does account for the potential of a building being developed. The mass that fronts Delridge provides a strong 'Urban Edge' that reflects the future context of the site, while the setback mass on 18th Ave creates a hierarchy in the massing that reflects the residential street.

7.0 DESIGN GUIDELINES

ITEMIZED RESPONSE TO EDG 1

BOARD'S RECOMMENDATION:

1.d. The Board was particularly concerned about the large expanses of blank wall proposed on the north and south facades. The Board directed the applicant to integrate glazing into these facades to reduce the impacts associated with the blank walls and to improve solar access for residents. At the next EDG meeting, show fenestration for each proposed massing model. (CS1-B-2, DC2-B-2)

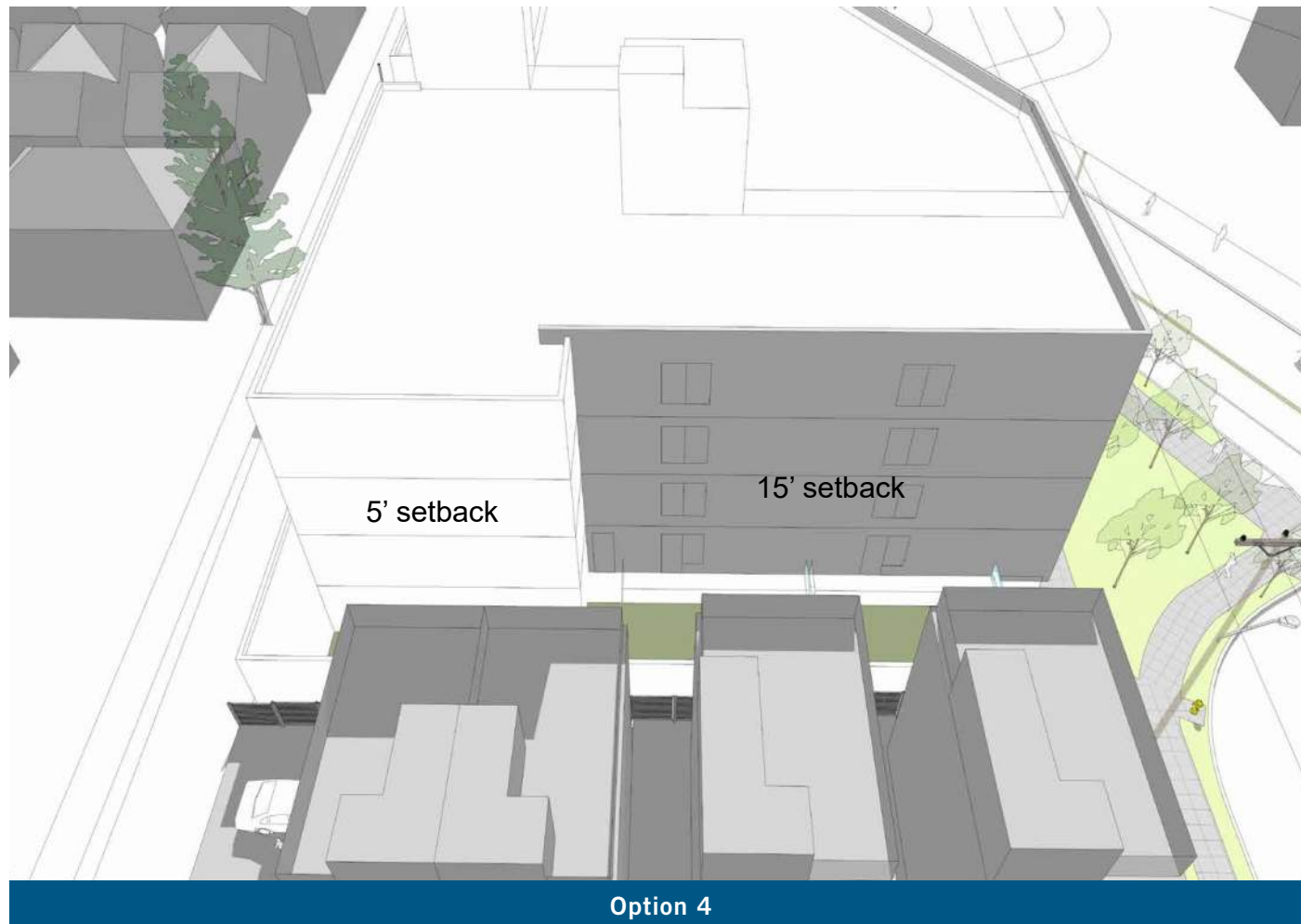

RESPONSE: This option divides the north facade into two masses that prevents an expanse of blank wall. The 15' setback from the north property line allows the integration of fenestration on the facade. Carefully located windows reduce the chance for privacy concerns for both the building tenants and the adjacent townhouses.

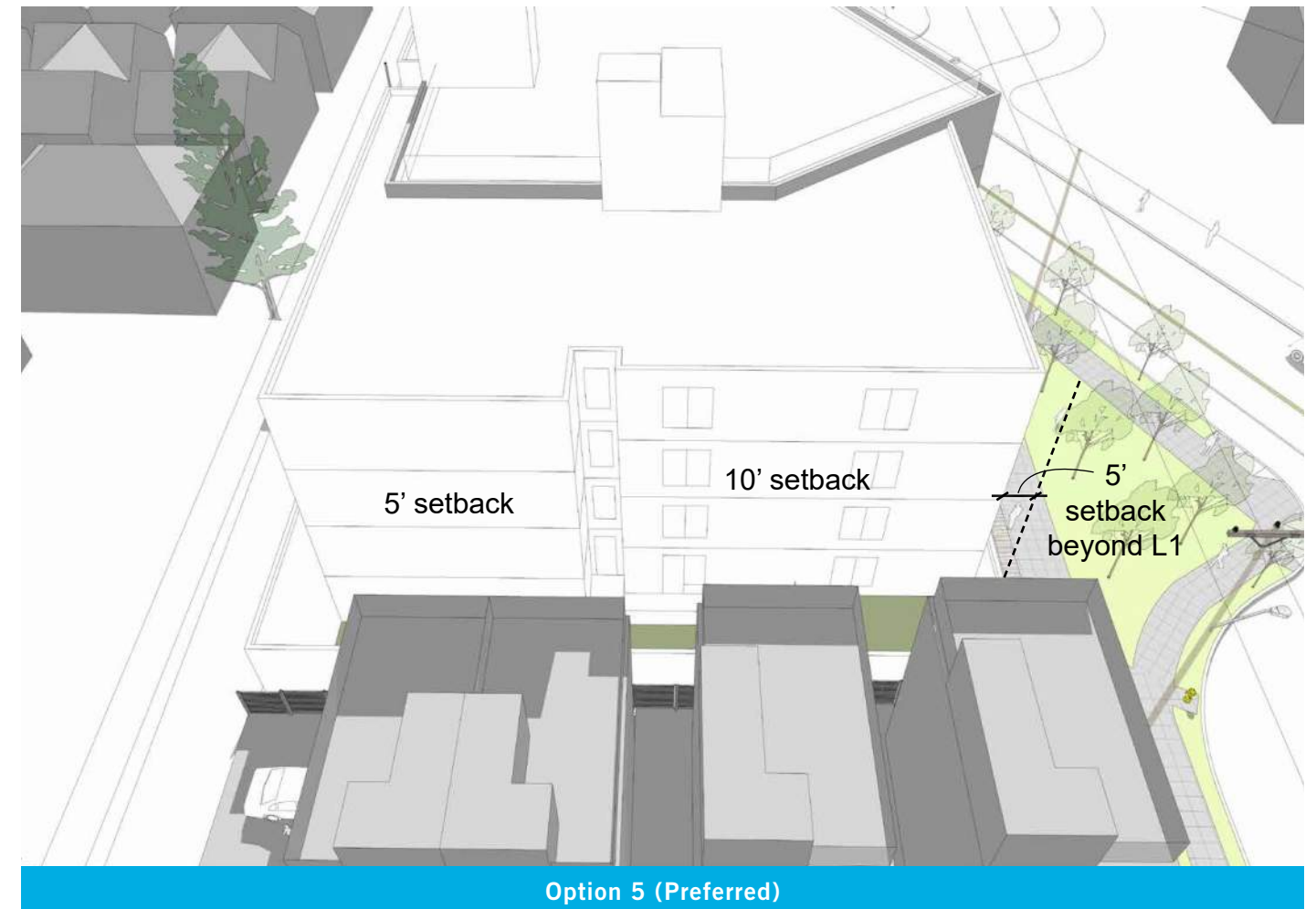

RESPONSE: This option divides the north facade into two masses that prevents an expanse of blank wall. The 10' setback from the north property line allows the integration of fenestration on the facade. A recess at the intersection of the corridor and north facade allows for additional fenestration. The addition of a 5' setback, above L1, on the western facade allows for additional natural light and air to reach the townhouse. Carefully located windows reduce the chance for privacy concerns for both the building tenants and the adjacent townhouses.

7.0 DESIGN GUIDELINES

ITEMIZED RESPONSE TO EDG 1

BOARD'S RECOMMENDATION:

1.d. The Board was particularly concerned about the large expanses of blank wall proposed on the north and south facades. The Board directed the applicant to integrate glazing into these facades to reduce the impacts associated with the blank walls and to improve solar access for residents. At the next EDG meeting, show fenestration for each proposed massing model. (CS1-B-2, DC2-B-2)



RESPONSE: This option balances the number of units that would be affected if the southern site is developed while allowing for a strong facade along Delridge. The blank wall on the south facade is reduced to the length of the southeast units (measures 38' wide by 40' tall). Since, the southeast units have its fenestration along the alley, there is no concern for natural light and air penetration. The two remaining units along the south facade are setback a distance of 11' to allow for fenestration.



RESPONSE: This option balances the number of units that would be affected if the southern site is developed while allowing for a strong facade along Delridge. The blank wall on the south facade is reduced to the length of the southeast units (measures 38' wide by 40' tall). Since, the southeast units have its fenestration along the alley, there is no concern for natural light and air penetration. The two remaining units along the south facade are setback a distance of 11'-6" to allow for fenestration.

7.0 DESIGN GUIDELINES

ITEMIZED RESPONSE TO EDG 1

BOARD'S RECOMMENDATION:

1.e. The Board noted the relatively large size of the proposed commercial space and anticipated that market conditions may necessitate dividing the commercial space into smaller spaces. The Board asked the applicant to be mindful of this possibility as the design is developed to ensure a flexible ground floor that can evolve over time while retaining a strong connection to the public realm. (DC2-E)

1.f. The Board raised concerns about pedestrian connectivity and the streetscape experience. The Board recommended creating opportunities for activity to spill out into the public right-of-way to create a more active and engaging public realm. (PL1-B-3, PL3-C)



Option 4

RESPONSE: This option uses a continuous facade along the ground floor to allow for maximum flexibility of the commercial space. The internal layout of the commercial space allows for easy demising for future tenants. Although the fence to the south encroaches into the R.O.W., the acute awkward angle is eliminated by setting a portion of the ground floor facade perpendicular to the side lot line. The use of a setback on the ground floor allows for retail activities to spill out and the addition of vegetation creates a secondary layer to the space.



Option 5 (Preferred)

RESPONSE: Although this option divides the facade along the ground floor into two portions, the internal layout allows for easy demising for future tenants. Although the fence to the south encroaches into the R.O.W., the acute awkward angle is eliminated by setting a portion of the ground floor facade perpendicular to the side lot line. The use of a setback on the ground floor allows for retail activities to spill out and the addition of vegetation creates a secondary layer to the space.

7.0 DESIGN GUIDELINES

ITEMIZED RESPONSE TO EDG 1

BOARD'S RECOMMENDATION:

2.a. The Board noted that the blank wall condition of the south façade results in reduced solar access for the residential units. As the design is further developed, keep internal solar access in mind and allow this consideration to inform the overall design concept and internal layout. (CS1-B-2, DC2-B-2)

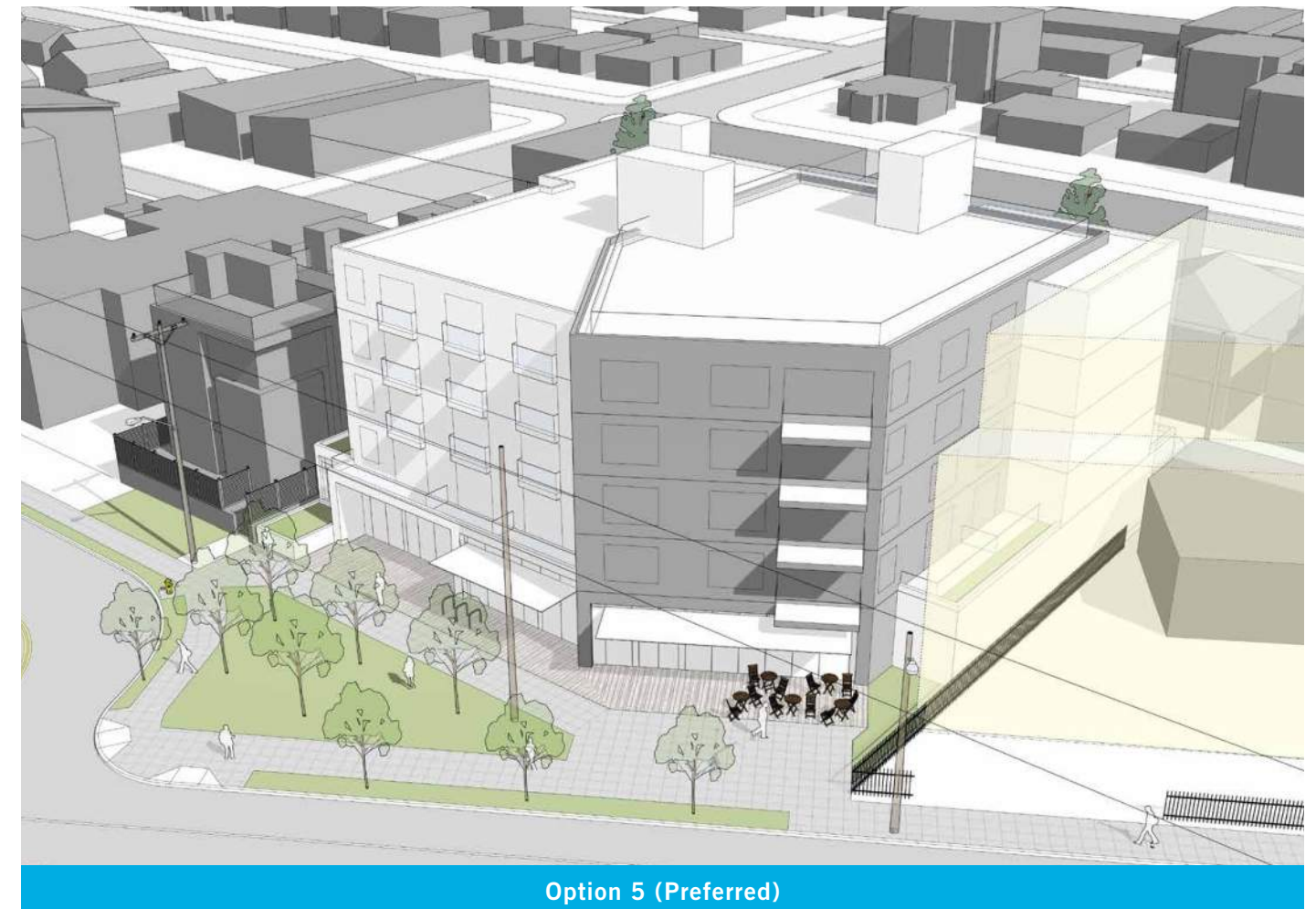
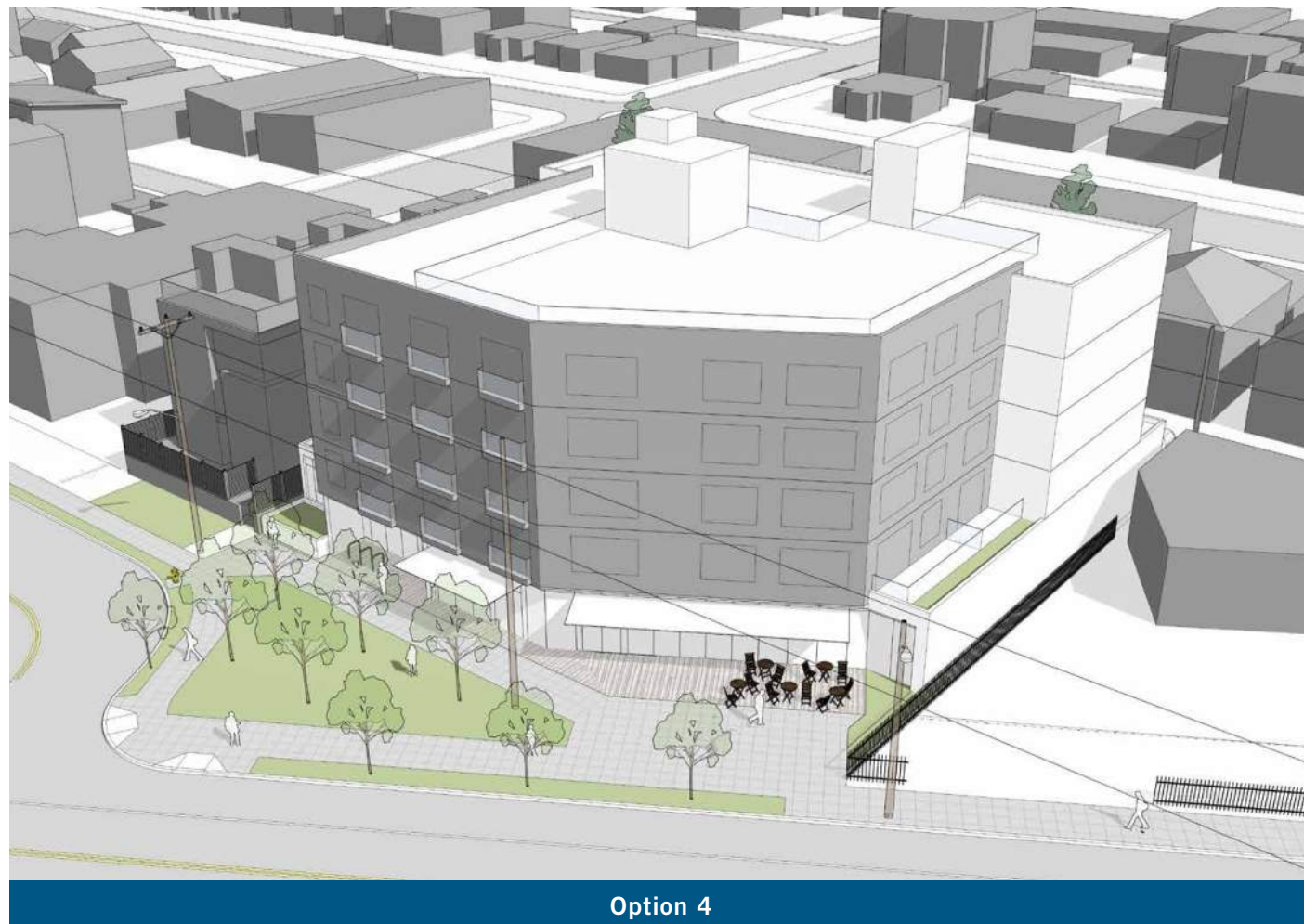

RESPONSE: This option strikes a balance between maximizing natural light and air to penetrate all units, while acknowledging the townhouses to the north and the potential southern site development. This is accomplished by having the majority of unit fenestrations face the site street and alley. Along the north and south facades, setback are utilized to allow for fenestration while providing mutual relief for the building and adjacent sites. Overall, there are only two units per floor that have their fenestration on the north or south facade.

RESPONSE: This option strikes a balance between maximizing natural light and air to penetrate all units, while acknowledging the townhouses to the north and the potential southern site development. This is accomplished by having the majority of unit fenestrations face the site street and alley. Along the north and south facades, setback are utilized to allow for fenestration while providing mutual relief for the building and adjacent sites. Overall, there are only two units per floor that have their fenestration on the north or south facade.

7.0 DESIGN GUIDELINES

ITEMIZED RESPONSE TO EDG 1

BOARD'S RECOMMENDATION:

2.b. The Board recommended setting back the upper levels to improve solar access for neighboring properties. (CS1-B-2)

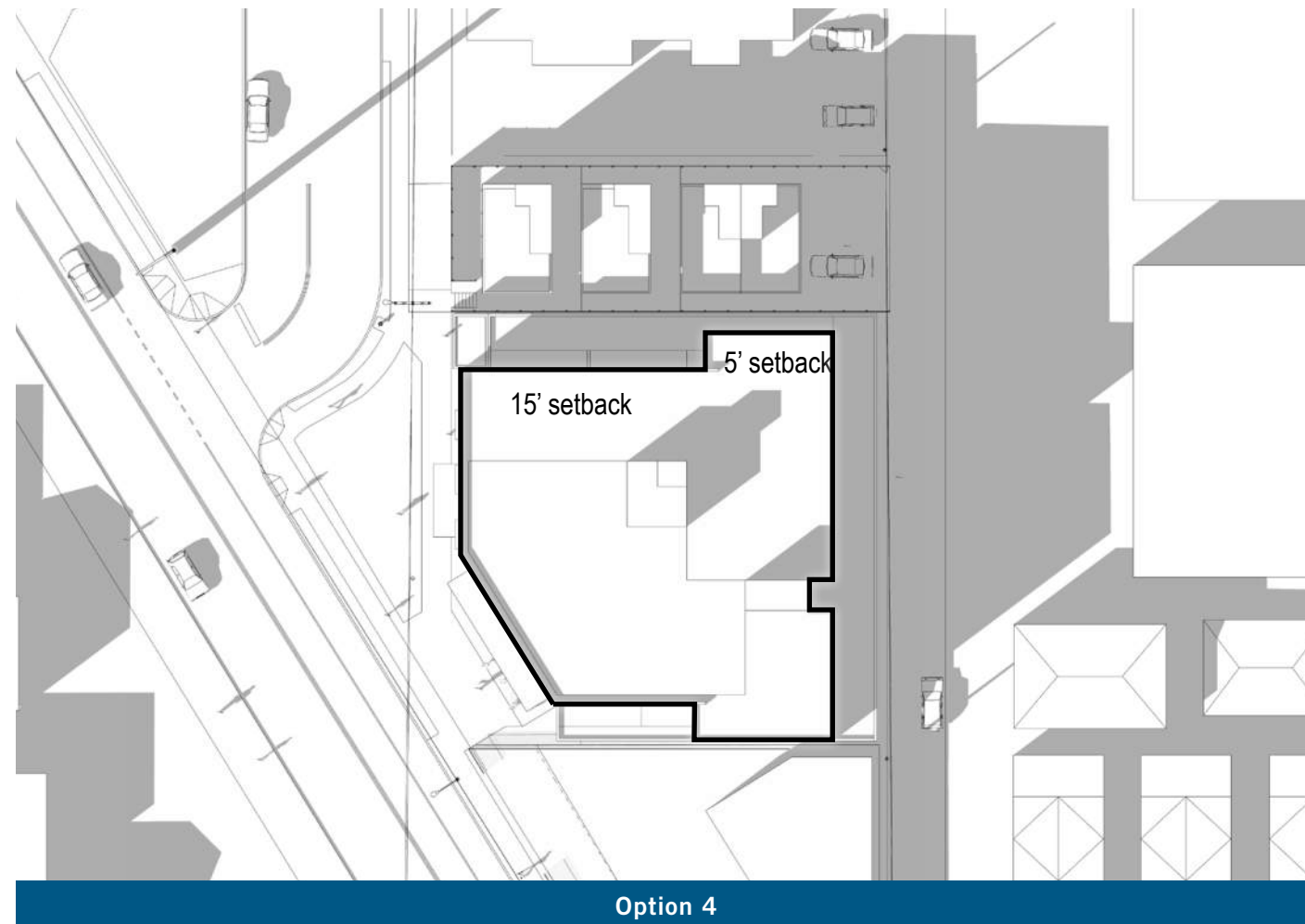

RESPONSE: When compared to Option 5, the proposed additional 5' setback on the NW upper facade of the building, doesn't noticeably reduce the shadows cast onto the existing townhouses. Additionally, the SW upper portion of the building is setback 11' to allow for natural light and air penetration even with the potential of the southern site development.

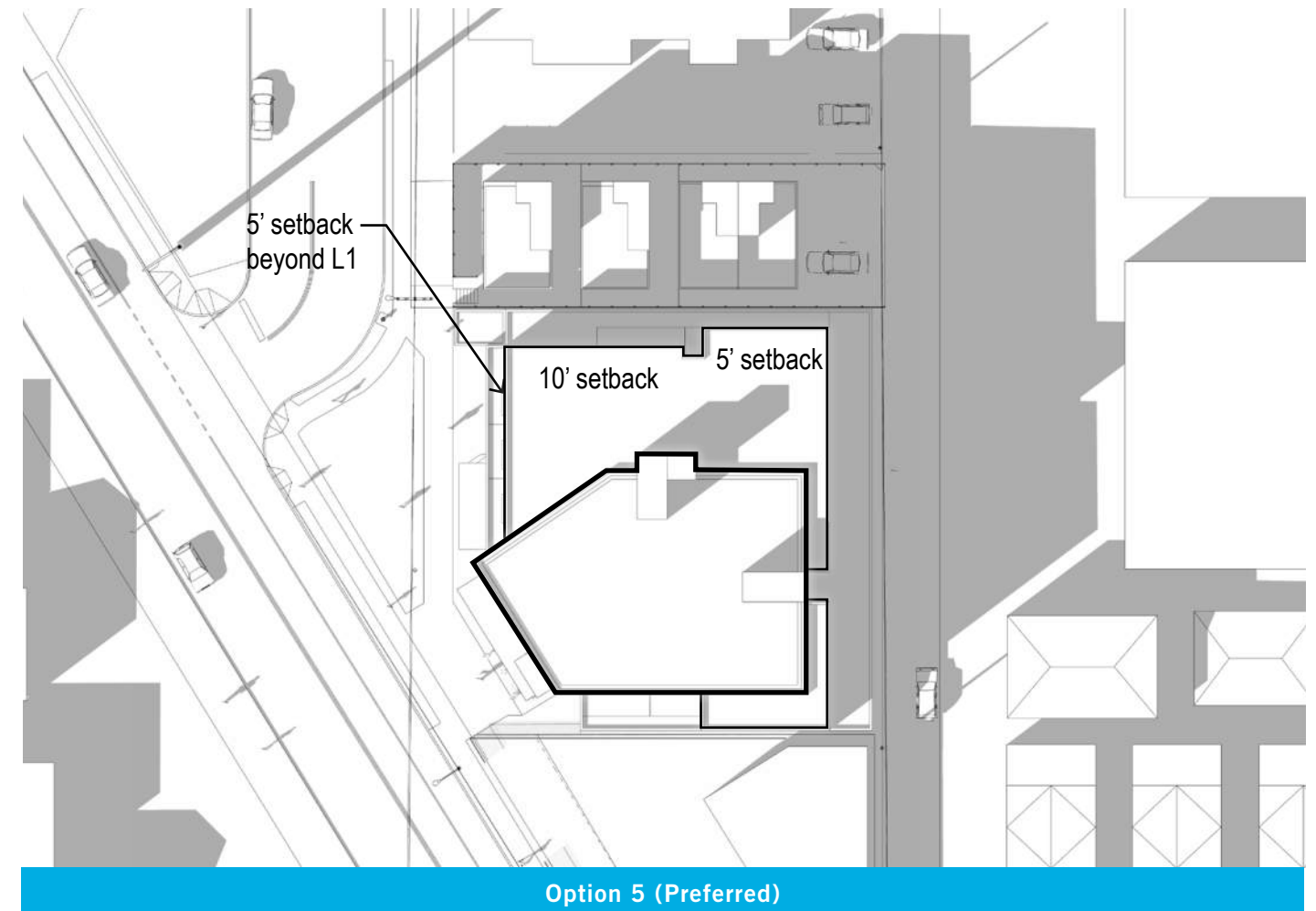

RESPONSE: The proposed 10' setback on the NW upper facade of the building gives relief to the adjacent townhouses. A 5' setback on the west facade creates additional space for natural light and air penetration. When compared to Option 4, the shadows cast are similar. Additionally, the SW upper portion of the building is setback 11'-6" to allow for natural light and air penetration even with the potential of the southern site development.

7.0 DESIGN GUIDELINES

ITEMIZED RESPONSE TO EDG 1

BOARD'S RECOMMENDATION:

3.a. The Board raised concerns about potential privacy impacts on adjacent properties and requested that a window overlap study be provided at the next meeting. (CS2-D-5)

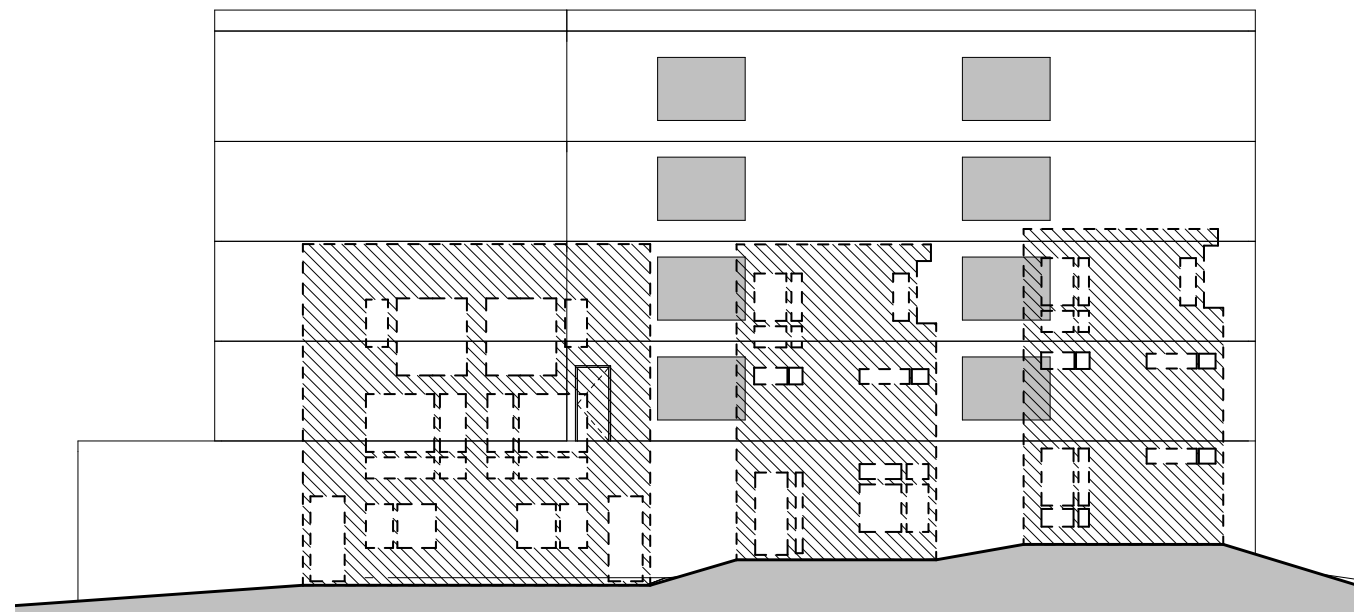

Option 4

RESPONSE: xxx

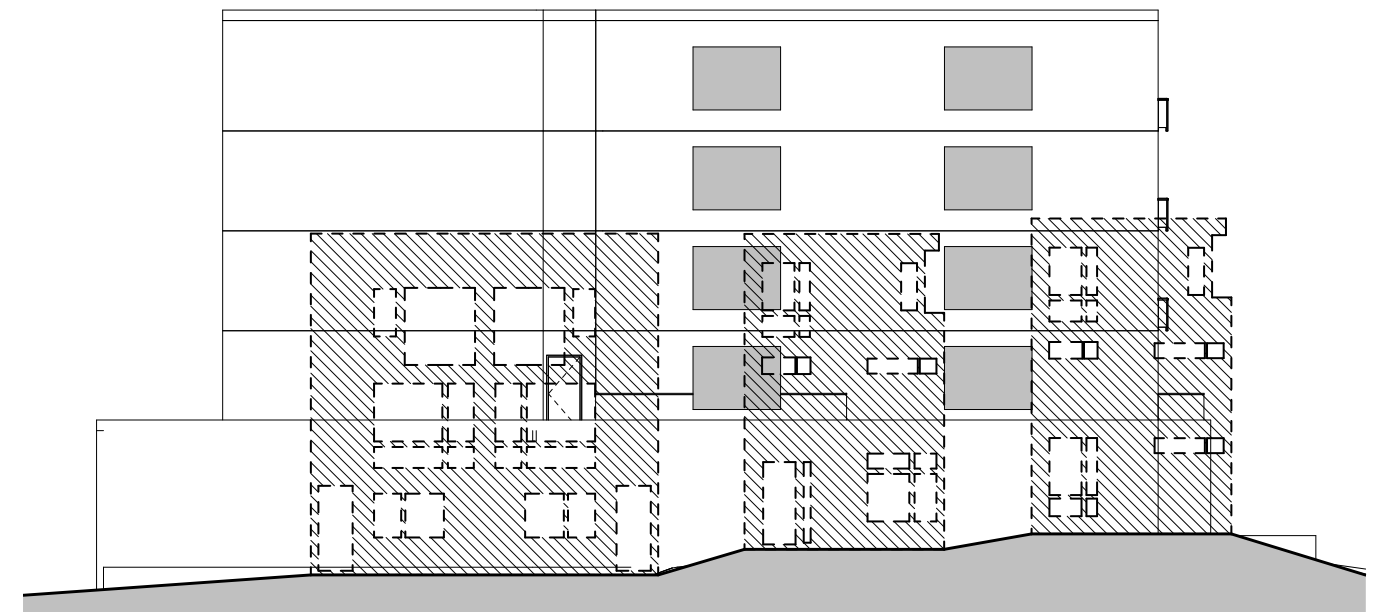

Option 5 (Preferred)

RESPONSE: xxx

8.0 ARCHITECTURAL MASSING CONCEPTS | EDG 1



	Option 1	Option 2	Option 3 (Preferred)
CONCEPT:	Orient to Delridge	Intersecting Boxes	Sliding Frames
# UNITS:	55	55	59
AMENITY SF (OUTDOOR):	3,125	4,067	3,772
AMENITY SF (INDOOR)	986	1,413	1,167
COMMERCIAL SF:	4,567	4,486	5,242
PARKING STALLS:	28	25	25
BIKE STALLS:	55 Long-Term, 10 Short-Term	57 Long-Term, 10 Short-Term	60 Long-Term, 10 Short-Term
FAR SF:	47,036	49,699	49,244
OPPORTUNITIES:	<ul style="list-style-type: none"> • Strong frontage facing Delridge. • Facade along 18th Ave SW pulled back to allow for articulation with balconies & to allow space between adjacent townhouse to the north. • Residential entrance pulled away from 18th Ave SW to allow for generous plaza on northwest side of site. 	<ul style="list-style-type: none"> • Simple geometric relationship between masses. • Generous plaza on southwest of site connects to Delridge Triangle • Northwest corner is set back to let light and space to adjacent development. 	<ul style="list-style-type: none"> • Responds well to the scale of the existing area, ie. 1-story retail & the adjacent 3-story townhomes • Setback from powerlines allows for facade articulation on 18th Ave SW. • Setback from north property line gives space to townhouses and allows for fenestration. • Generous residential lobby entrance to the north. • Generous plaza on southwest of site connects to Delridge Triangle.
CONSTRAINTS:	<ul style="list-style-type: none"> • Large facade facing Delridge does not fit the scale of the street and area • Majority of north facade is built right up to the property line and shades 3 of the 4 townhomes to the north. • Blank facade on north wall due to zero lot line condition. • Stair core located on north facade. • Irregular shaped units difficult to lay out. • Unit windows on southern facade may be covered with future development. 	<ul style="list-style-type: none"> • Blank facades on north and south wall due to zero lot line conditions. • Majority of north facade is built right up to the property line and shades 3 of the 4 townhomes to the north. • Units on northwest side shaded most of the year. • Little articulation on wall closest to 18th Ave SW. • 5-story facade on 8th avenue does not respond to the predominant scale of buildings in the area, ie. 3-story townhomes. 	<ul style="list-style-type: none"> • Blank facade on south wall due to zero lot line condition.
CODE COMPLIANCE:	Yes, code compliant	Yes, code compliant	Yes, code compliant

8.0 ARCHITECTURAL MASSING CONCEPTS | EDG 2



	Option 4	Option 5 (Preferred)
# UNITS:	56	56
AMENITY SF (OUTDOOR):	3,415	3,690
AMENITY SF (INDOOR)	1,428	1,450
COMMERCIAL SF:	3,796	3,865
PARKING STALLS:	29	28
BIKE STALLS:	57 Long-Term, 6 Short-Term	57 Long-Term, 6 Short-Term
FAR SF:	48,059	46,705
OPPORTUNITIES:	<ul style="list-style-type: none"> • Strong urban edge on Delridge Way SW and 18th Ave SW. • Portion of north facade set back at 15' provides extra relief at north for townhouses. 	<ul style="list-style-type: none"> • Strong presence on Delridge Way SW and is differentiated from facade on 18th Ave SW. • Facade pulled back from 18th Ave SW allows for julliette balconies and suggests 18th being the more residential of the 2 streets. • Commercial facade is naturally divided into 2 sections for 2 smaller commercial spaces.
CONSTRAINTS:	<ul style="list-style-type: none"> • One mass along Delridge Way SW and 18th Ave SW appears monolithic. 	<ul style="list-style-type: none"> • 5' less setback at north next to townhouses.
CODE COMPLIANCE:	Yes, code compliant	Yes, code compliant

8.0 ARCHITECTURAL MASSING CONCEPTS

DESIGN PROCESS

STEP 1: GENERAL MASSING WITH POWERLINE SETBACKS

STEP 2: REFINE MASSING

STEP 3: FACADE TREATMENT

Option 4

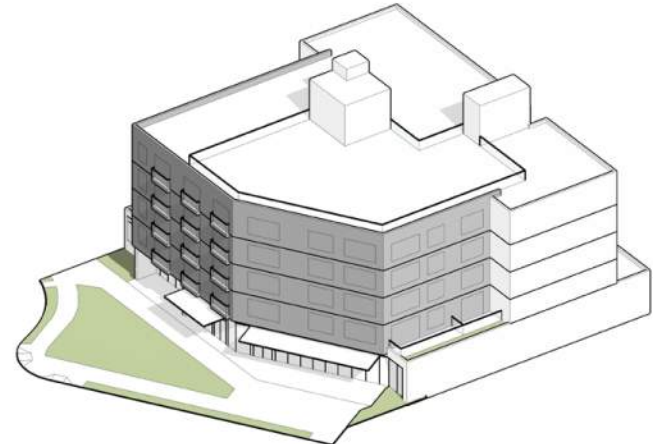
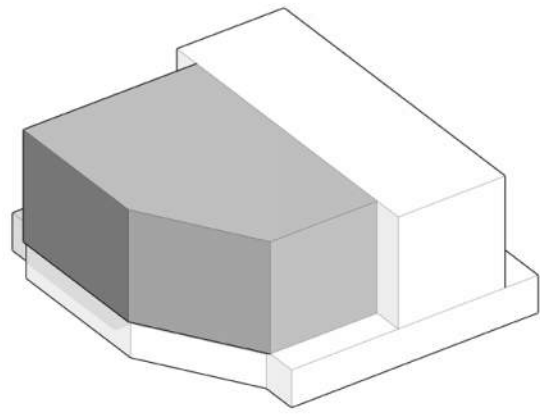
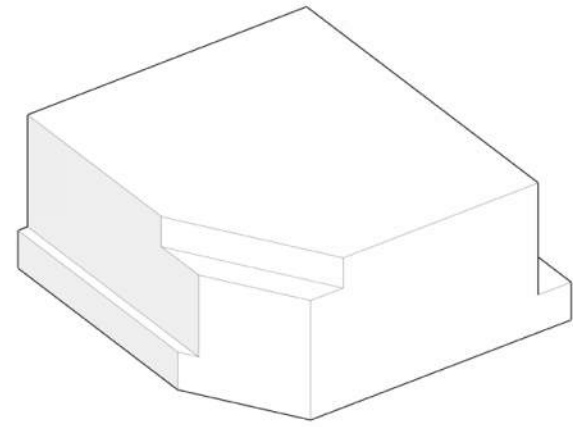

Option 5 (Preferred)

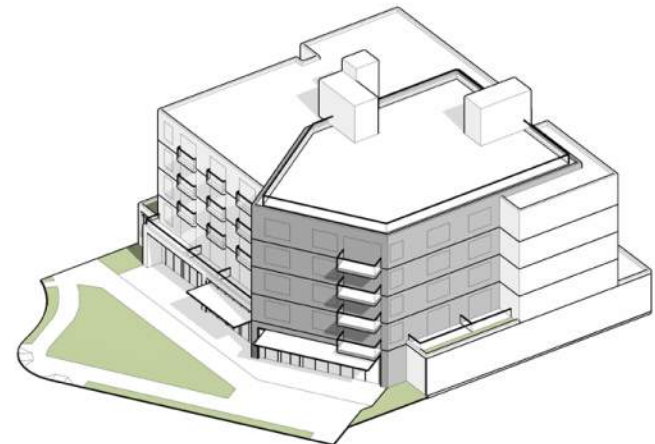
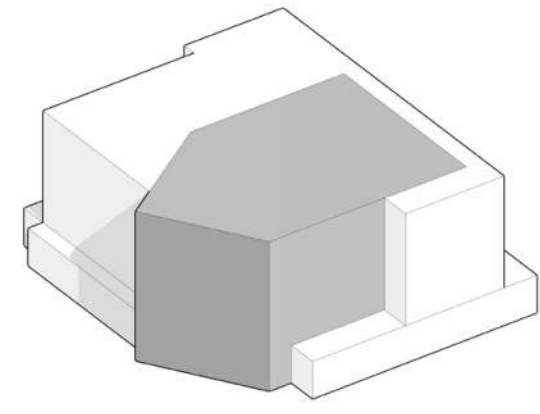
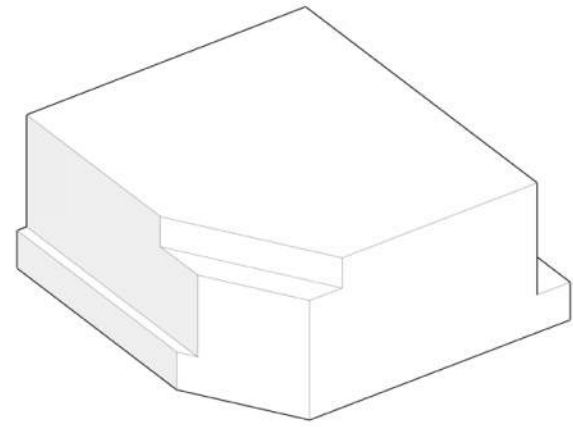

8.0 OPTION 4

OPTION 4

DESIGN PROS:

- ① Strong urban edge along Delridge Way SW and 18th Ave SW highlights interesting shape of site

DESIGN CONS:

- ① No hierarchy between Delridge Way SW and 18th Ave SW
- ② Blank facade on north and south

CONCEPT DIAGRAMS

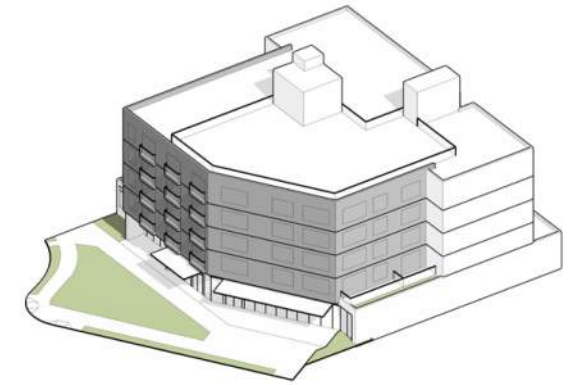
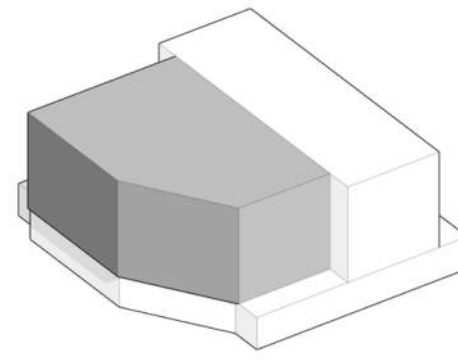
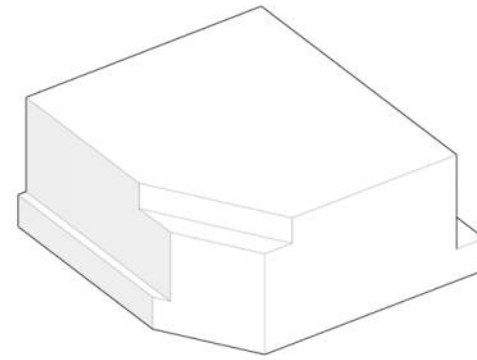

FINAL CONCEPT MASSING

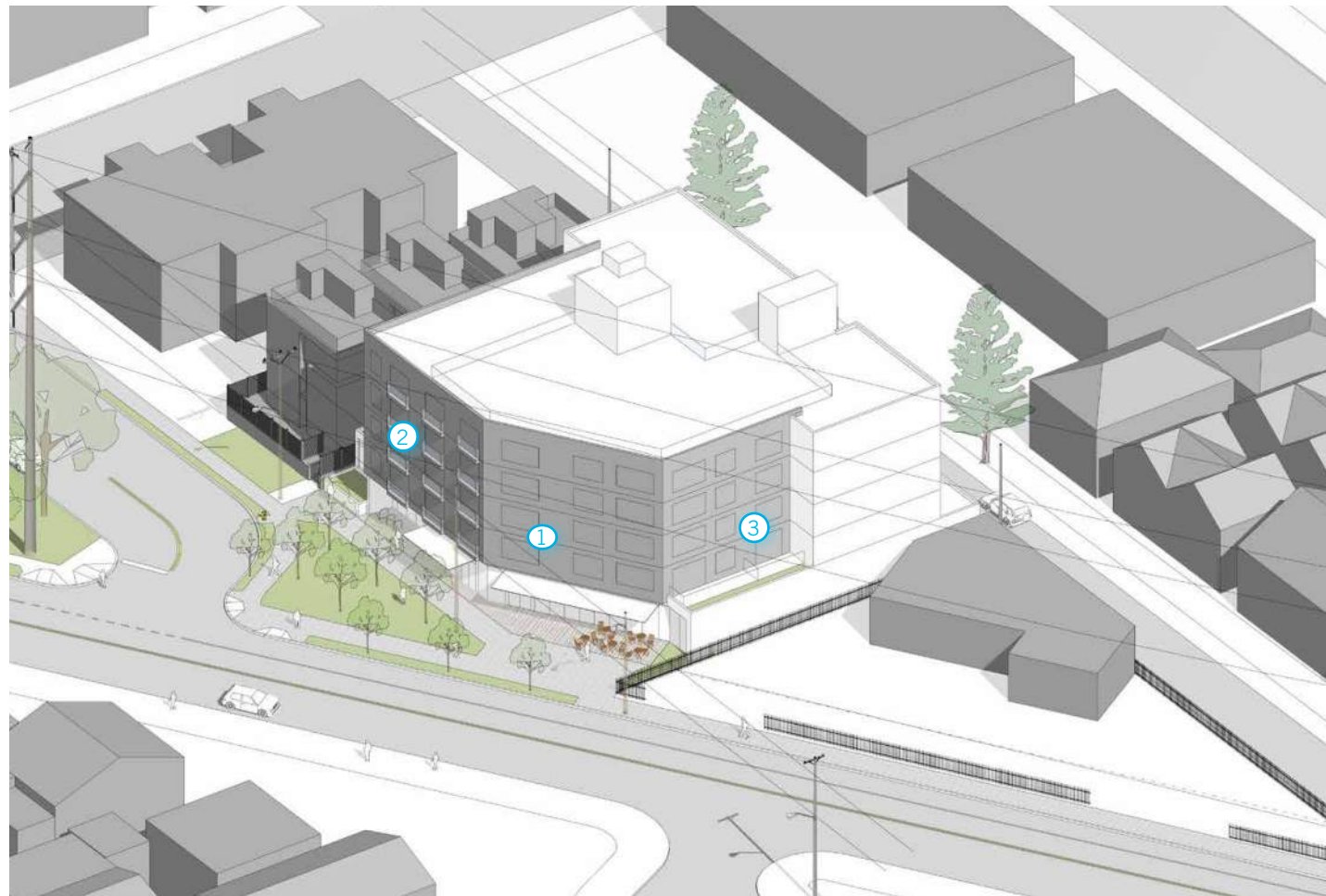

AXONOMETRIC VIGNETTE FROM SOUTHWEST

AXONOMETRIC VIGNETTE FROM NORTHWEST

- ① Strong urban edge along Delridge
- ② Setback along 18th Ave with more residential character
- ③ Setback on to allow for fenestration

8.0 OPTION 4 | PERSPECTIVES

DESIGN ANALYSIS



VIEW FROM DELRIDGE WAY SW



VIEW FROM DELRIDGE WAY SW AND 18TH AVE SW



VIEW FROM 18TH AVE SW



VIEW FROM DELRIDGE WAY SW LOOKING NORTH



VIEW FROM ALLEY LOOKING SOUTH

8.0 OPTION 4 | FLOOR PLANS

KEY

- Commercial
- Planting Strip
- Residential
- Residential Amenity
- Utility/BOH
- Parking/Garage
- Circulation
- Balcony

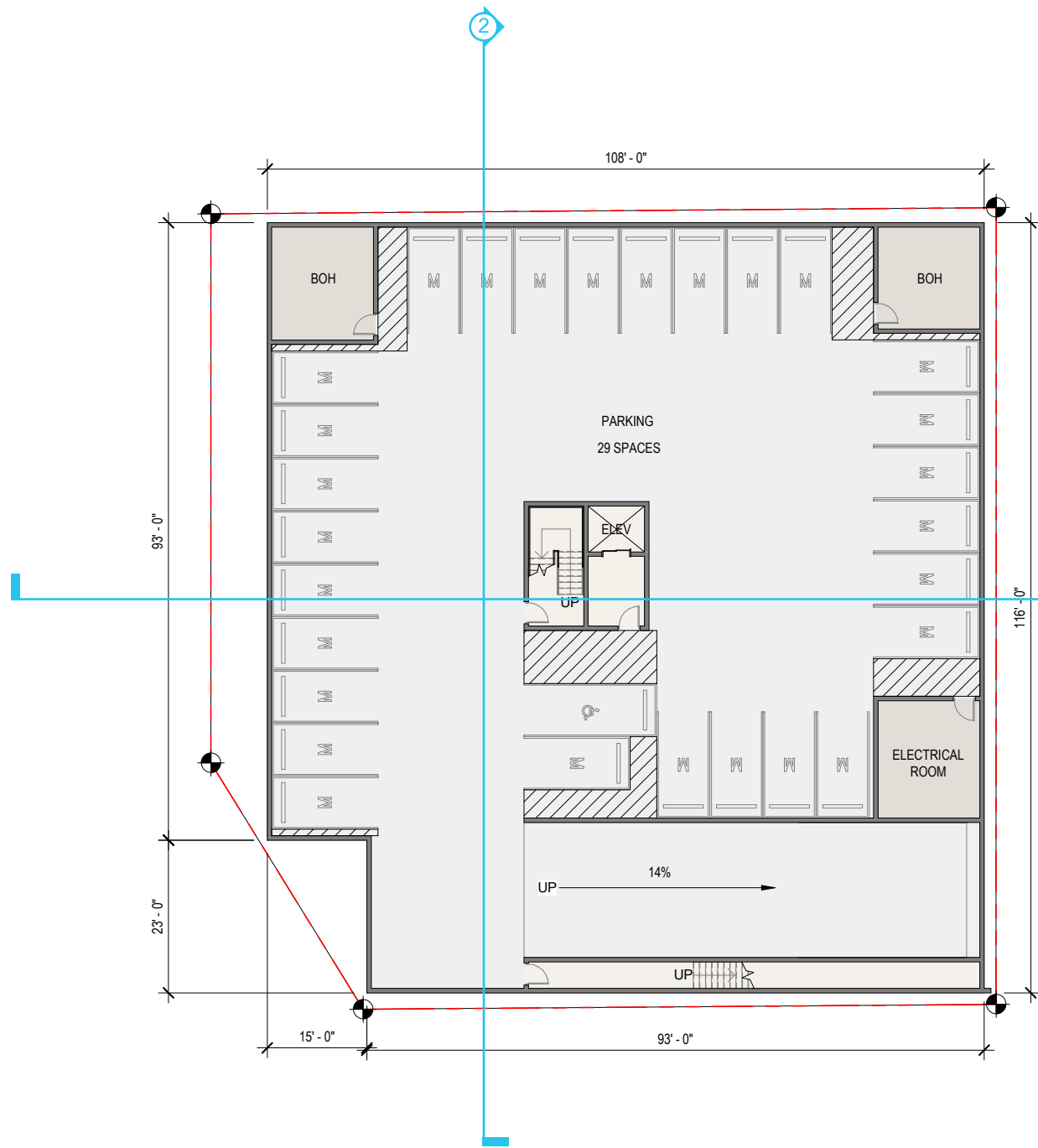

LEVEL P1



LEVEL 1



8.0 OPTION 4 | FLOOR PLANS

KEY

- Commercial
- Planting Strip
- Residential
- Residential Amenity
- Utility/BOH
- Parking/Garage
- Circulation
- Balcony

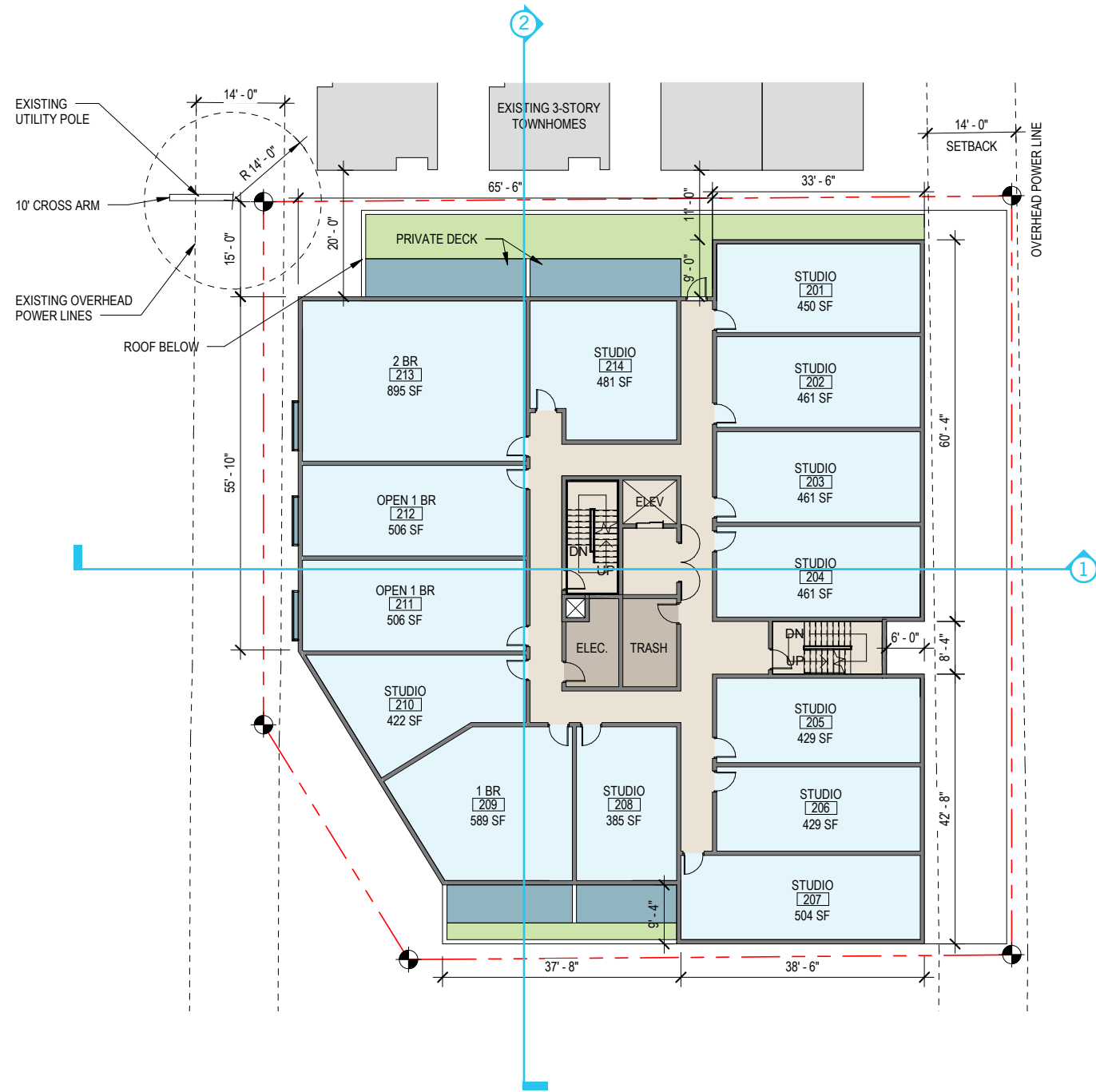

LEVEL 2

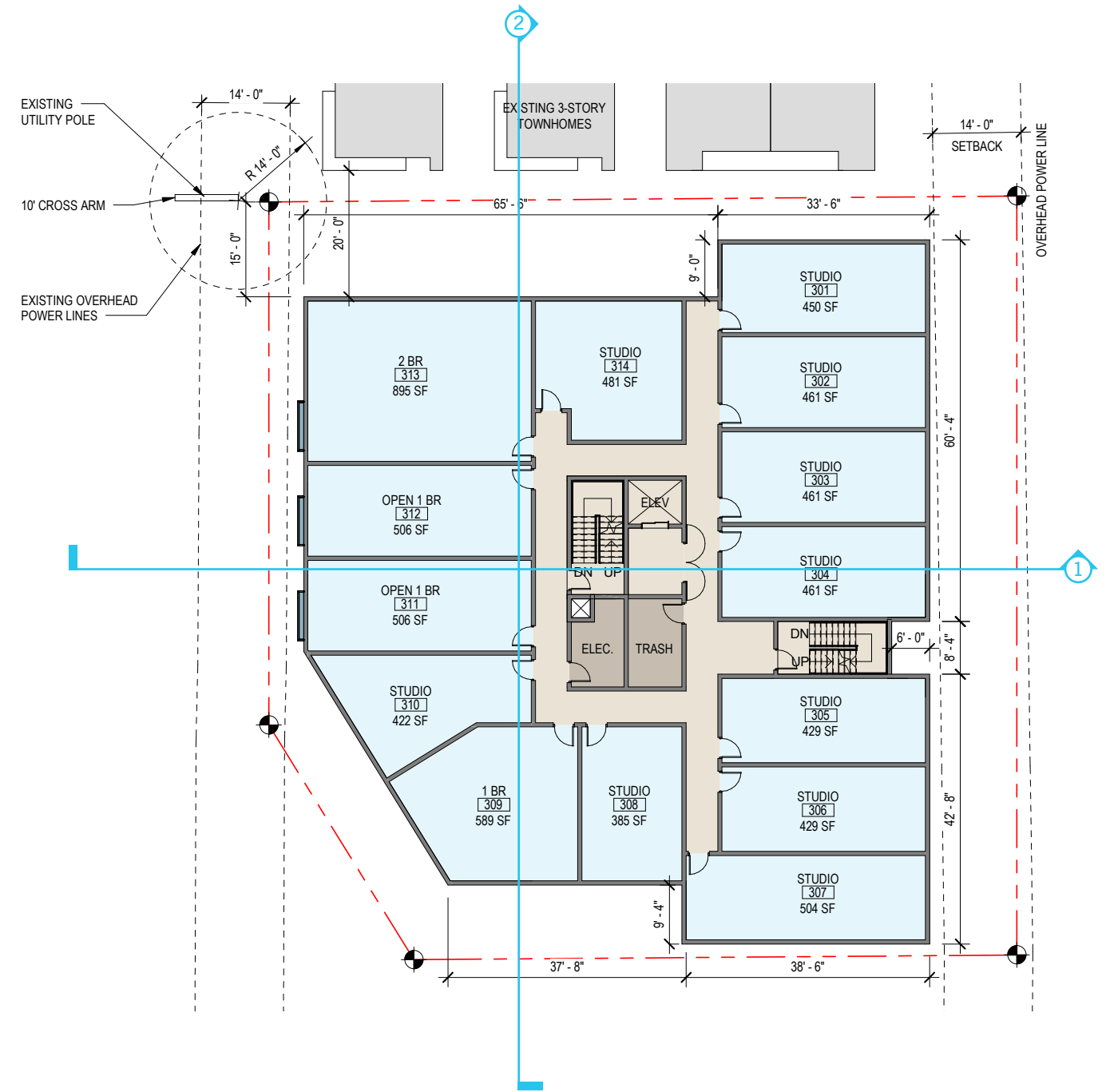

LEVEL 3-5



8.0 OPTION 4 | FLOOR PLANS

KEY

- Commercial
- Planting Strip
- Residential
- Residential Amenity
- Utility/BOH
- Parking/Garage
- Circulation
- Balcony

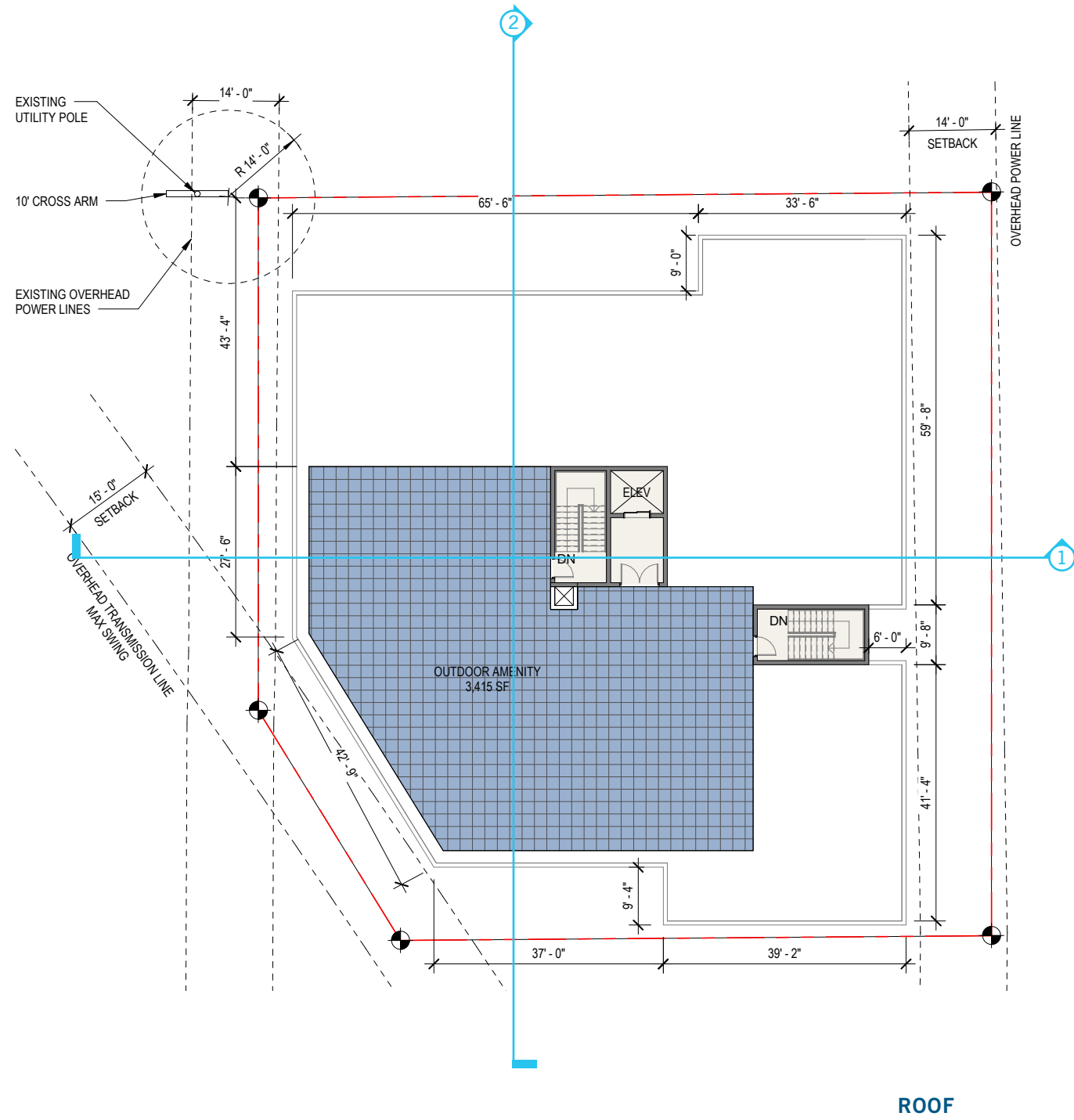

8.0 OPTION 4 | SECTIONS

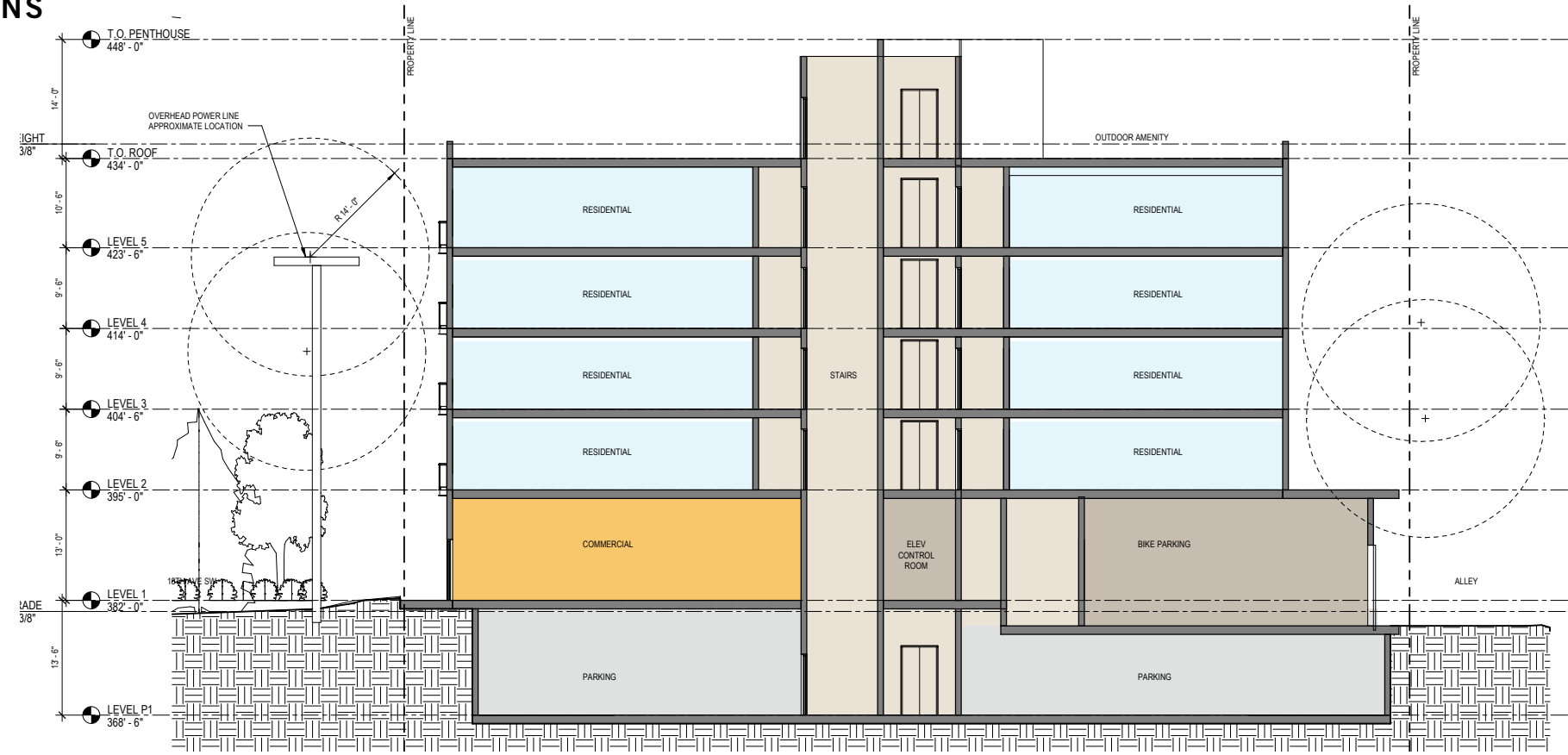

SECTION 1

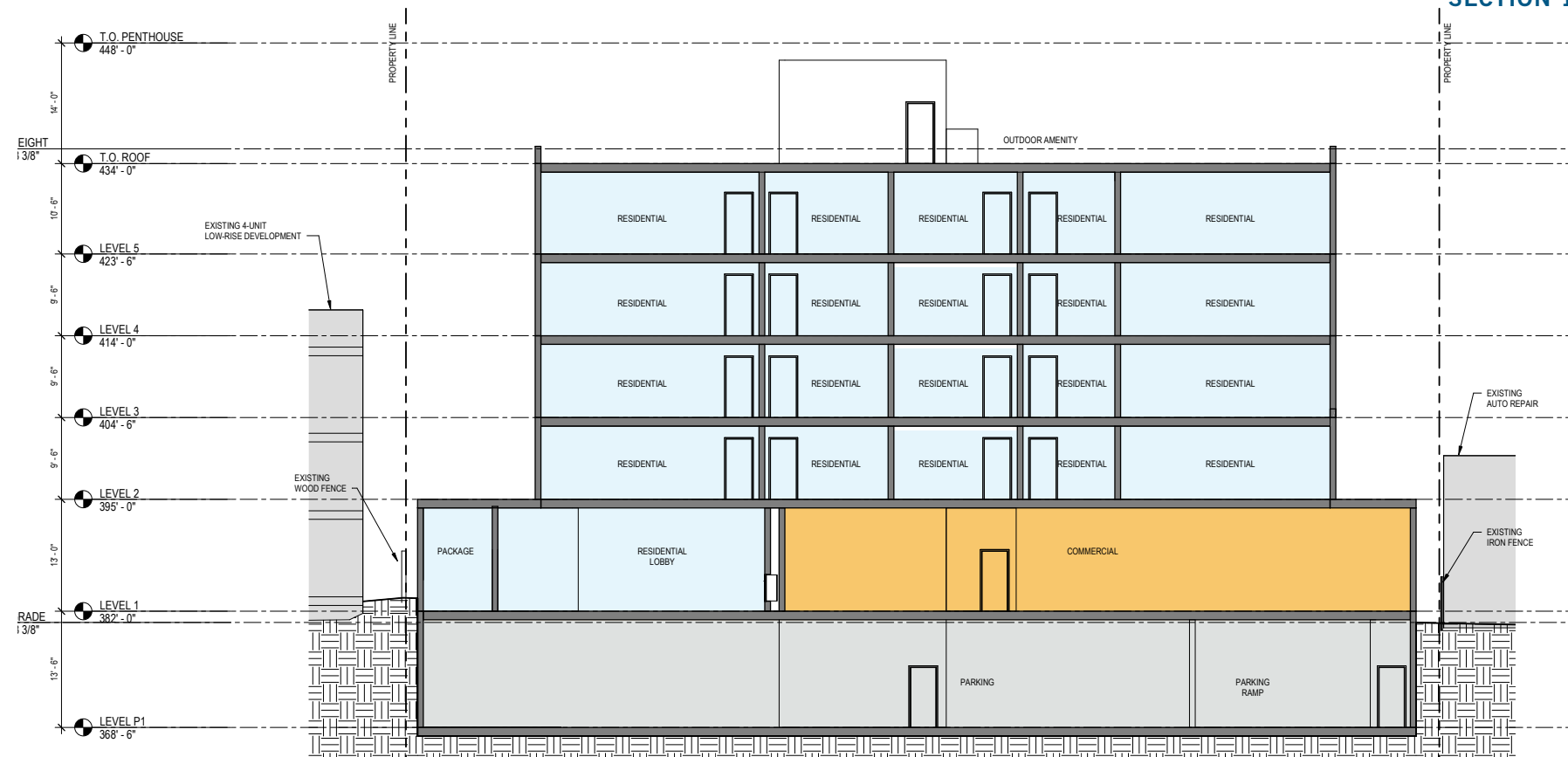

SECTION 2

- KEY**
- Commercial
 - Residential
 - Utility/BOH
 - Circulation
 - Parking

8.0 OPTION 4 | SHADOW STUDY

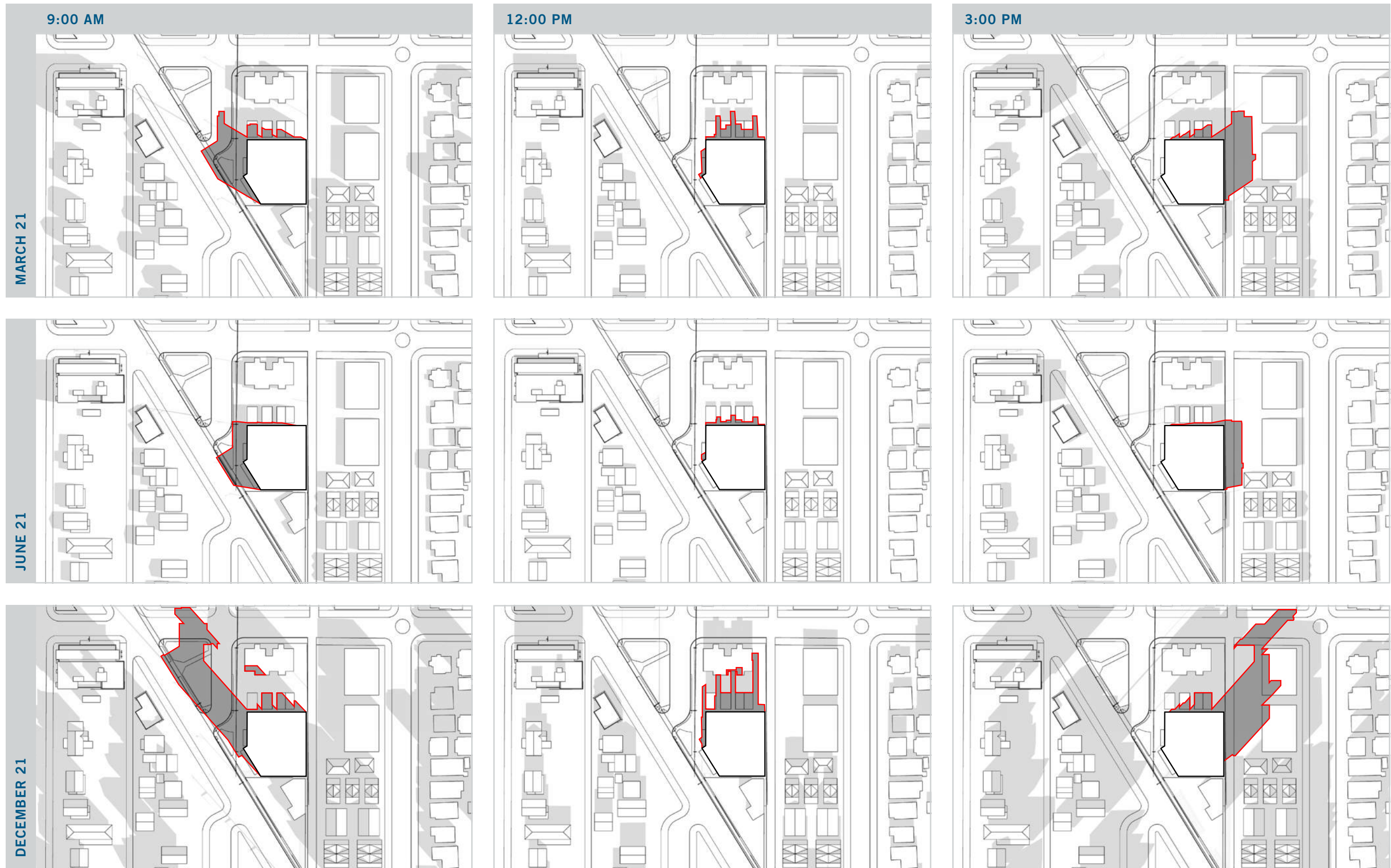

9.0 DEPARTURES

THIS PAGE INTENTIONALLY LEFT BLANK

8.0 OPTION 5 (PREFERRED)

OPTION 4

DESIGN PROS:

- ① Differentiates between Delridge Way SW and 18th Ave SW
- ② Intersecting masses highlight interesting shape of site
- ③ Commercial facade naturally divided into 2 smaller sections

DESIGN CONS:

- ① Blank facade on north and south

CONCEPT DIAGRAMS

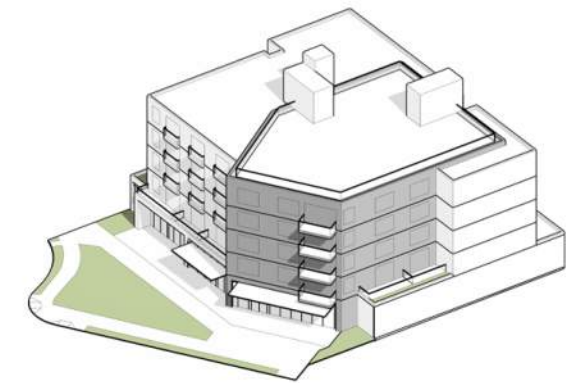
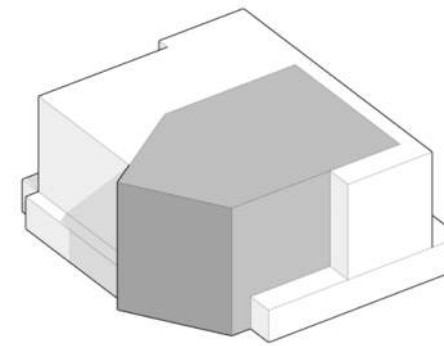
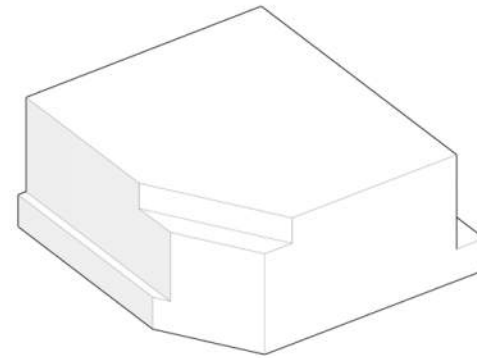

FINAL CONCEPT MASSING



AXONOMETRIC VIGNETTE FROM SOUTHWEST

AXONOMETRIC VIGNETTE FROM NORTHWEST

- ① Strong urban edge along Delridge
- ② Setback along 18th Ave with more residential character
- ③ Setback on to allow for fenestration

8.0 OPTION 5 (PREFERRED) | PERSPECTIVES

DESIGN ANALYSIS



VIEW FROM DELRIDGE WAY SW



VIEW FROM DELRIDGE WAY SW AND 18TH AVE SW



VIEW FROM 18TH AVE SW



VIEW FROM DELRIDGE WAY SW LOOKING NORTH



VIEW FROM ALLEY LOOKING SOUTH

8.0 OPTION 5 (PREFERRED) | FLOOR PLANS

KEY

- Commercial
- Planting Strip
- Residential
- Residential Amenity
- Utility/BOH
- Parking/Garage
- Circulation
- Balcony

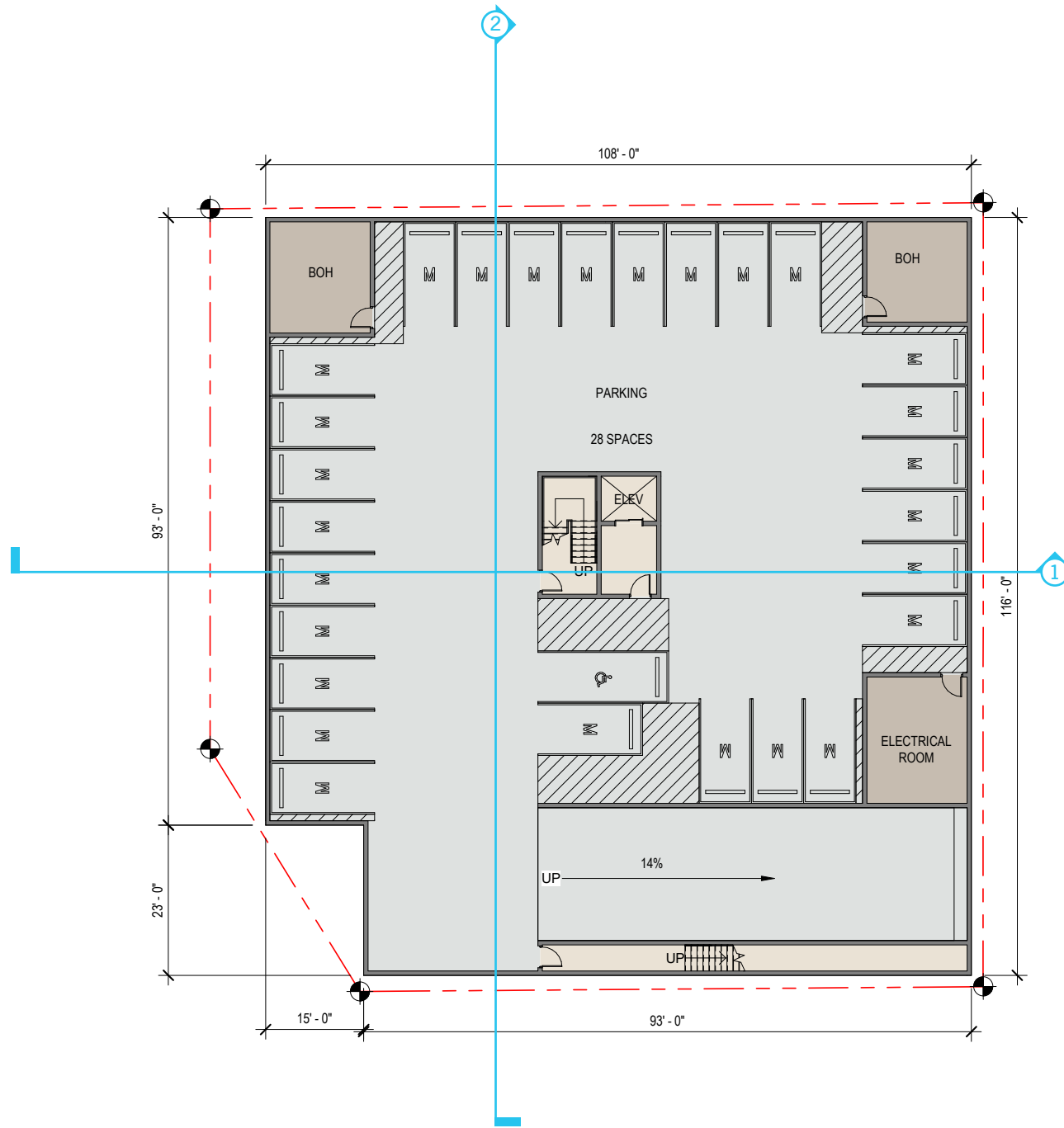

LEVEL P1



LEVEL 1



8.0 OPTION 5 (PREFERRED) | FLOOR PLANS

KEY

- Commercial
- Planting Strip
- Residential
- Residential Amenity
- Utility/BOH
- Parking/Garage
- Circulation
- Balcony

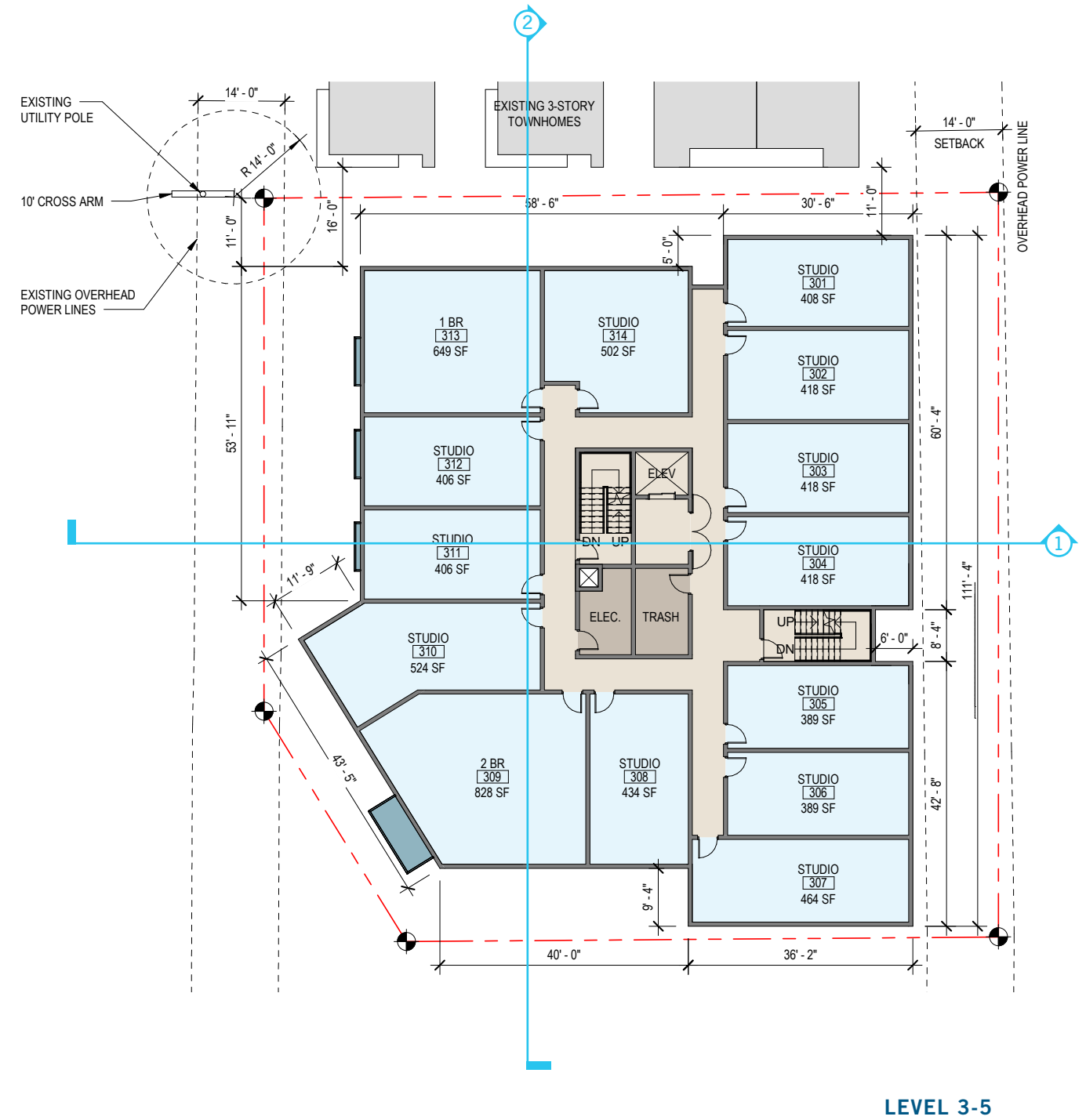
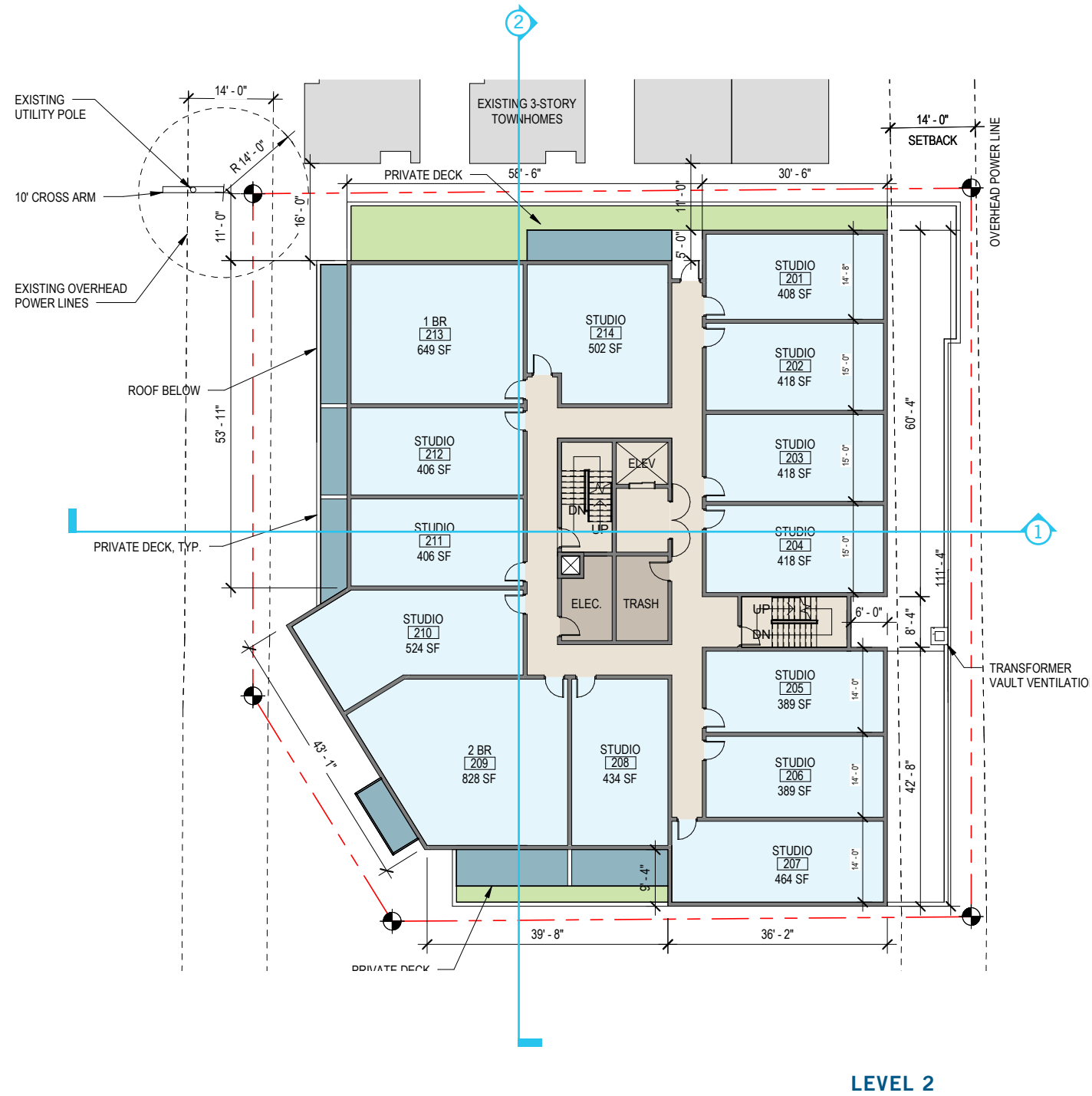

8.0 OPTION 5 (PREFERRED) | FLOOR PLANS

KEY

- Commercial
- Planting Strip
- Residential
- Residential Amenity
- Utility/BOH
- Parking/Garage
- Circulation
- Balcony

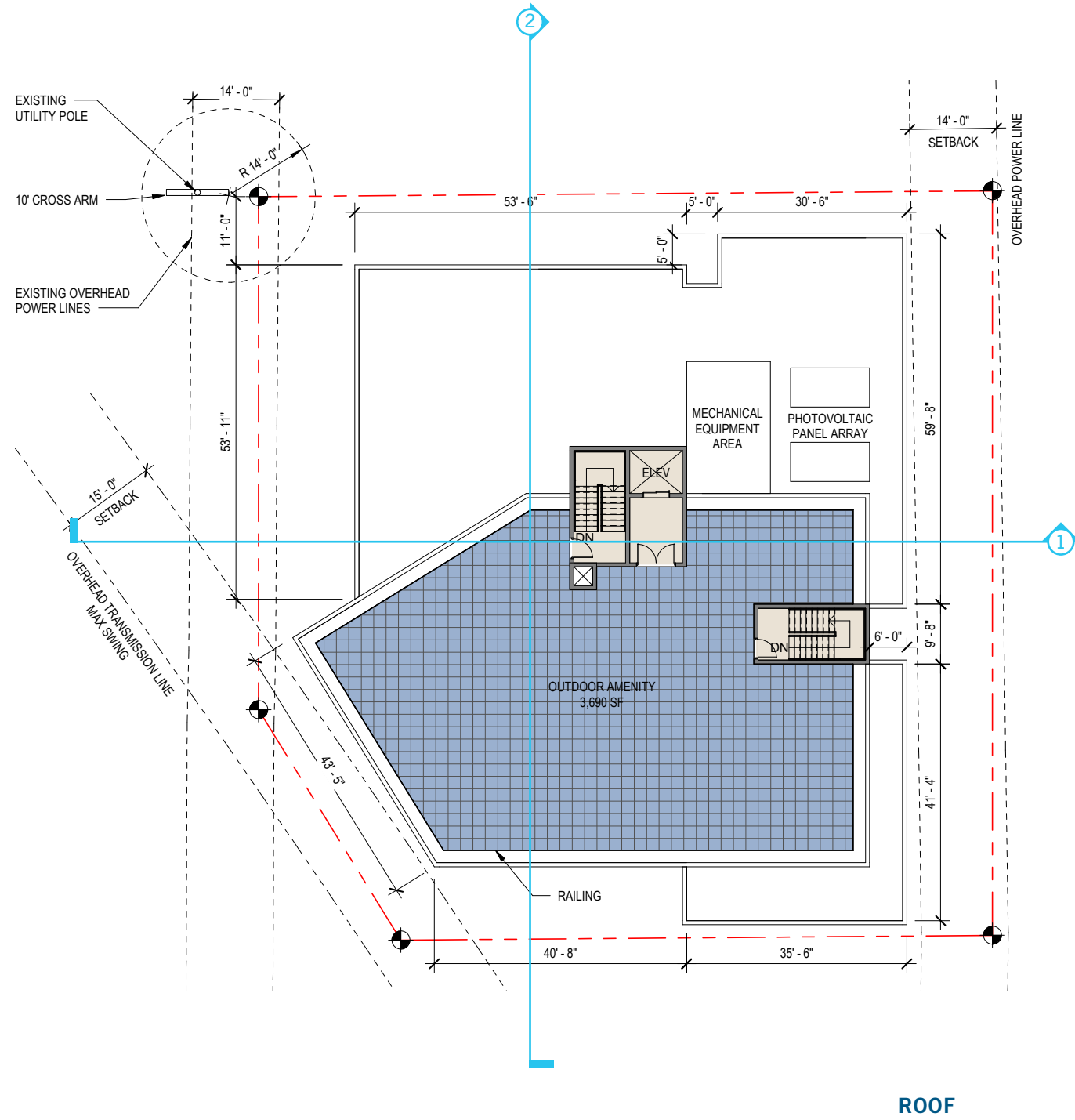

8.0 OPTION 5 (PREFERRED) | SECTIONS

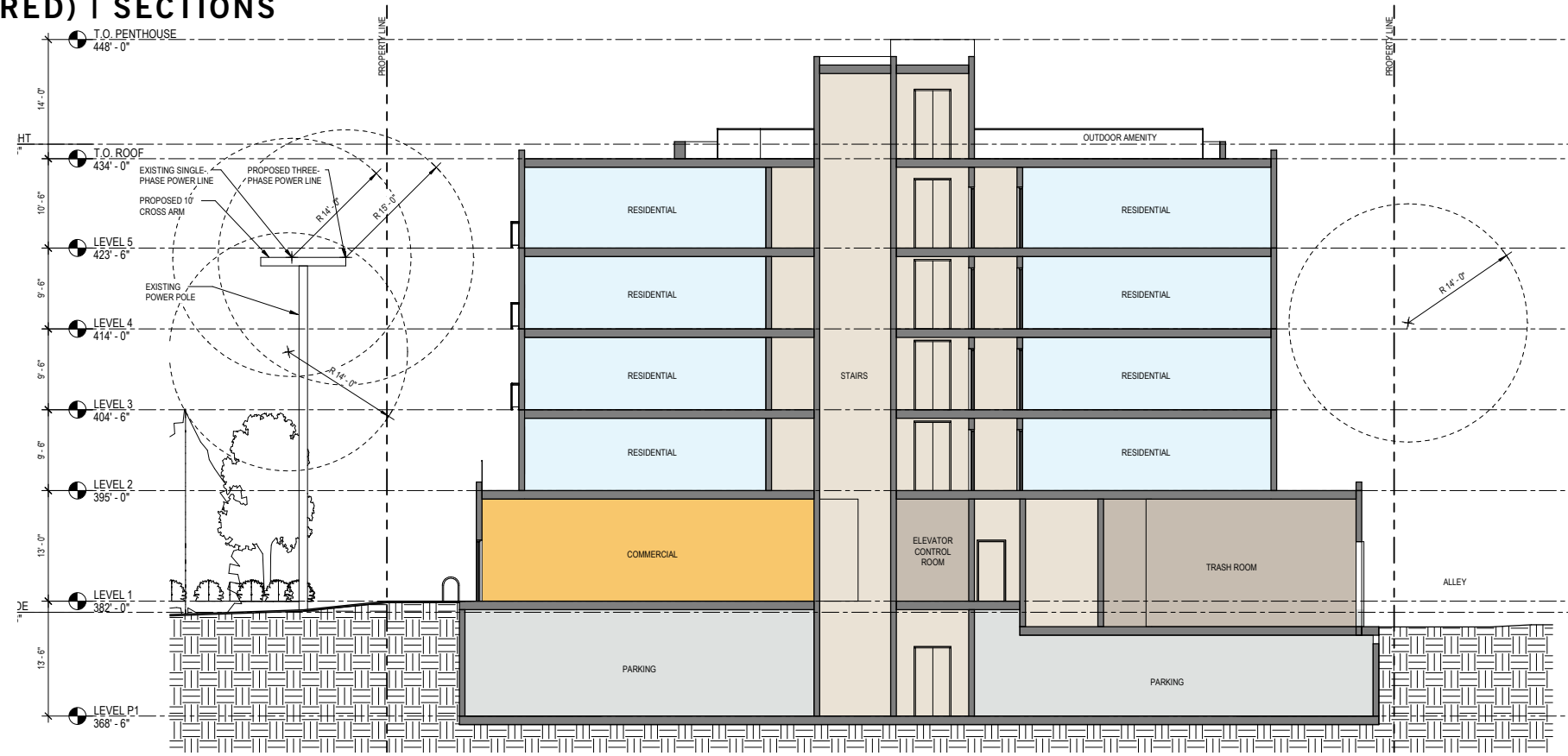

SECTION 1

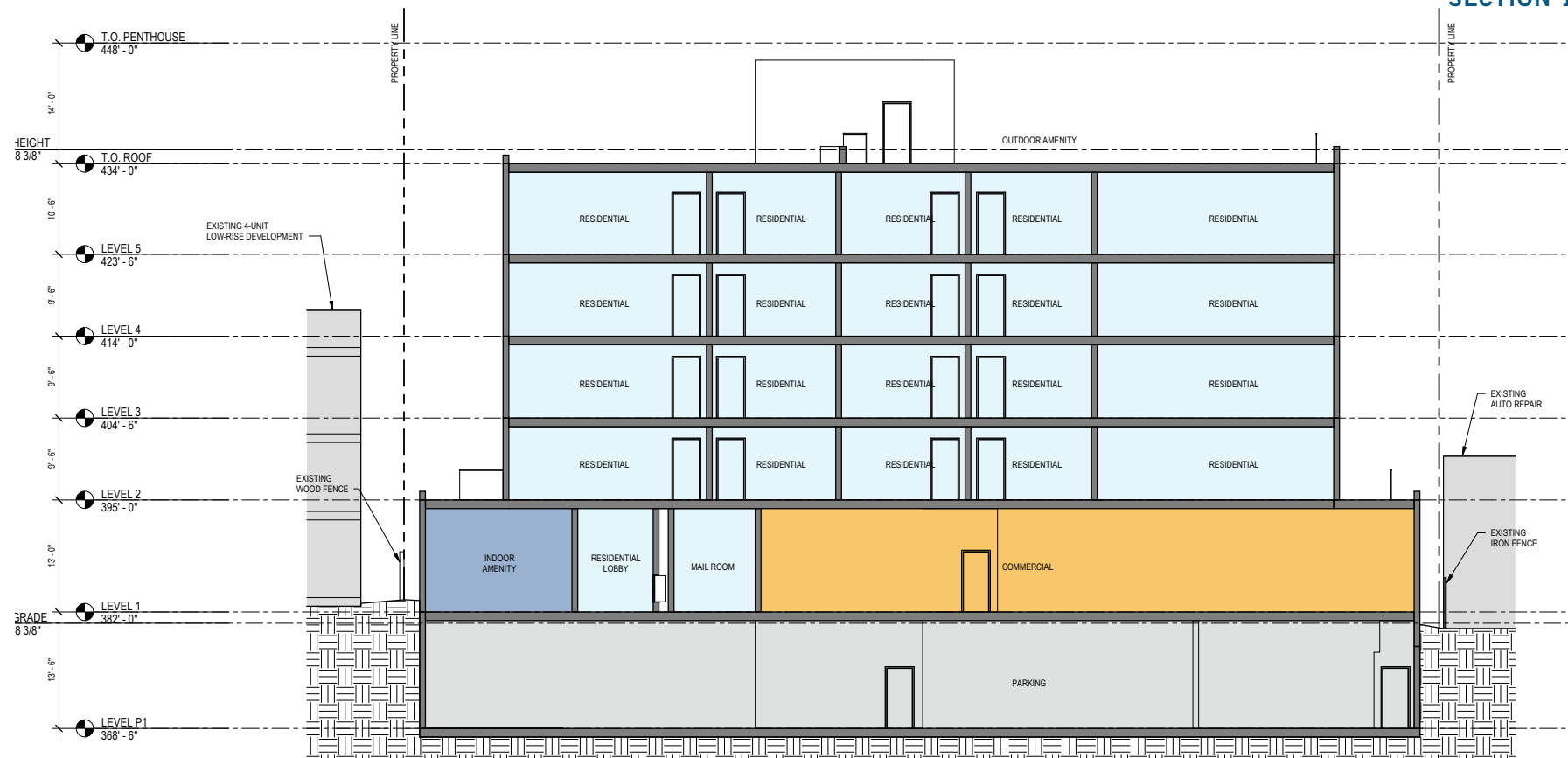

SECTION 2

KEY

- Commercial
- Residential
- Utility/BOH
- Circulation
- Parking

8.0 OPTION 5 (PREFERRED) | SHADOW STUDY

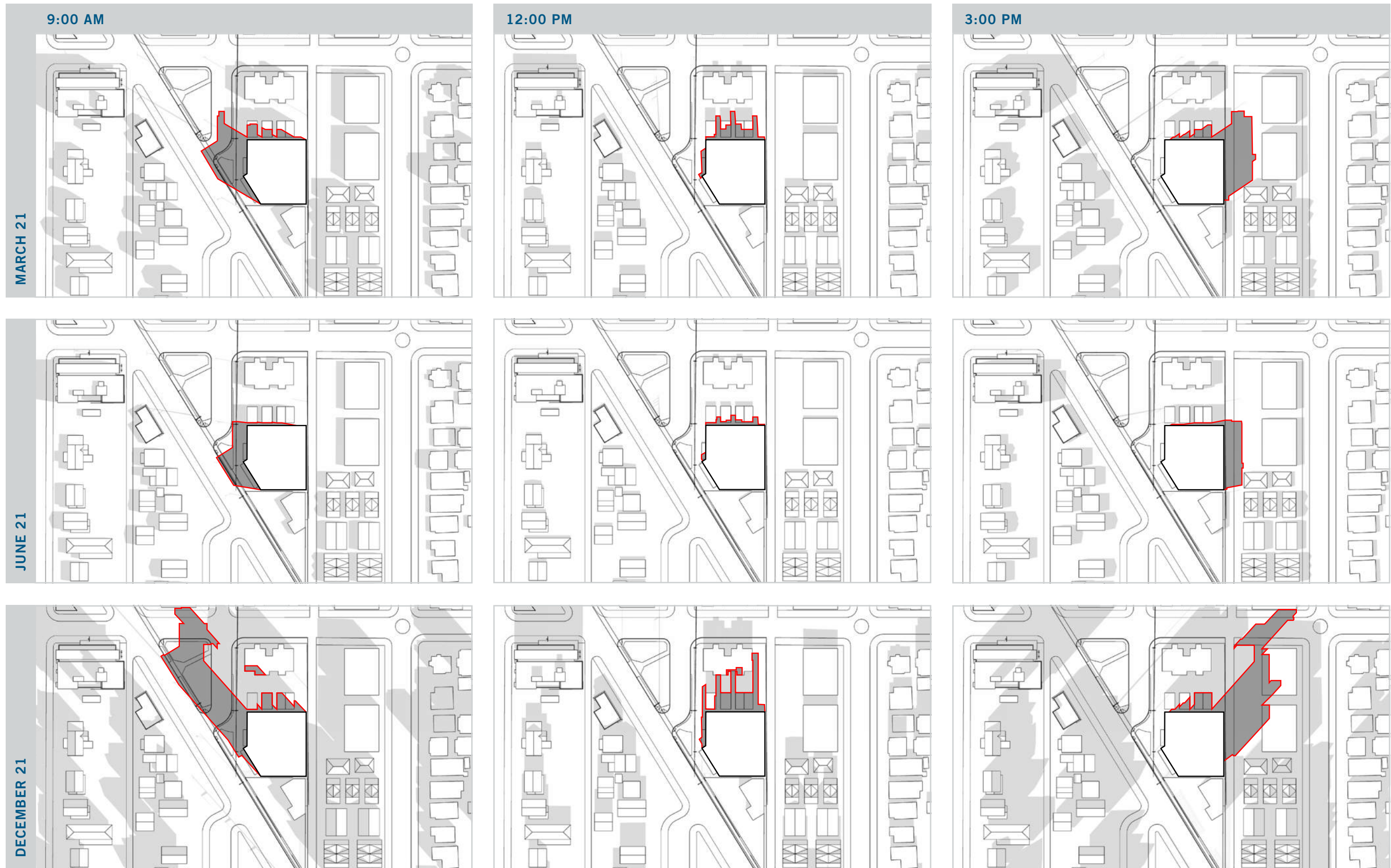

9.0 DEPARTURES

NO DEPARTURES ARE REQUESTED

Appendix 1: Additional Studies

APPENDIX 1 | ADDITIONAL STUDIES

ISSUE 1: STRONG URBAN EDGE ON DELRIDGE, STRONG CORNER OF DELRIDGE & 18TH

ISSUE 2: SIMPLIFY MASSING, REDUCE DECORATION



STUDY 1

Pro: Hierarchy is placed on facade facing Delridge and facade along 18th is pulled back suggesting that Delridge is more significant of the 2 streets while reinforcing the grid intersection.

Con: Facades facing 18th and south are unconsidered.



STUDY 2

Pro: Strong presence on Delridge and is differentiated from facade on 18th and south facade. Facade pulled back from 18th suggests that Delridge is more significant of the 2 streets while reinforcing the grid intersection.

Con:



STUDY 3

Pro: Strong urban edge on Delridge and 18th. Reinforces the grid being "broken".

Con: One "facade" along Delridge and 18th may appear monolithic.



STUDY 4

Pro: Strong urban edge on Delridge and 18th.

Con: One "facade" along Delridge and 18th may appear monolithic.



STUDY 5

Pro: Hierarchy is placed on facade facing Delridge while creating a strong urban edge on 18th as well.

Con:



STUDY 6

Pro: Simple design acknowledges odd shape of site and Delridge frontage.

Con: Emphasis is placed on first floor commercial along Delridge, which the board previously did not like.

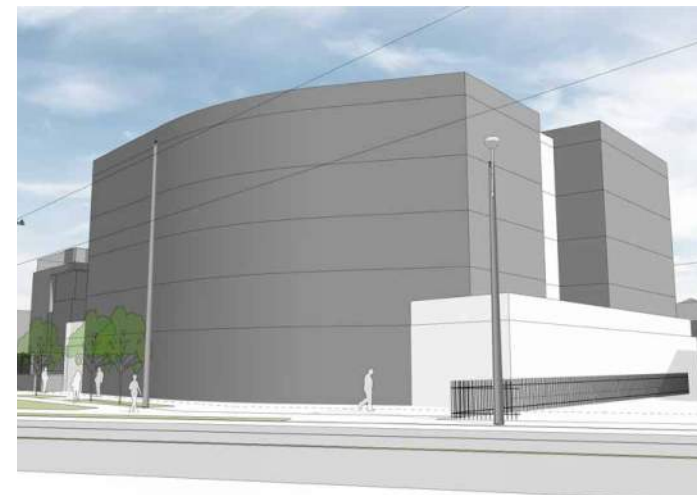

STUDY 7

Pro: Combines facades along 18th and Delridge to create a curve, which could be interesting.

Con: Hierarchy is not placed on Delridge.



STUDY 8

Pro: Simple design acknowledges odd shape of site and Delridge frontage.

Con: Emphasis is placed on first floor commercial along Delridge, which the board previously did not like.

APPENDIX 1 | ADDITIONAL STUDIES

ISSUE 3: EMBRACE THE FUTURE CONTEXT OF DELRIDGE



STUDY 1



STUDY 2



STUDY 3



STUDY 4

Because all the schemes are acknowledging the odd shape of the lot, I feel they are all embracing the future context of Delridge. The lot directly to the south is hard to imagine because of its odd shape, but if it were to be built out, any of these schemes would “embrace” that.



STUDY 5



STUDY 6



STUDY 7



STUDY 8

LR ZONE NC ZONE NC ZONE - TRIANGLE LOT (LESS LIKELY TO BE DEVELOPED)

APPENDIX 1 | ADDITIONAL STUDIES

ISSUE 4: PRIVACY (WINDOW STUDY, SHOW FENESTRATION)

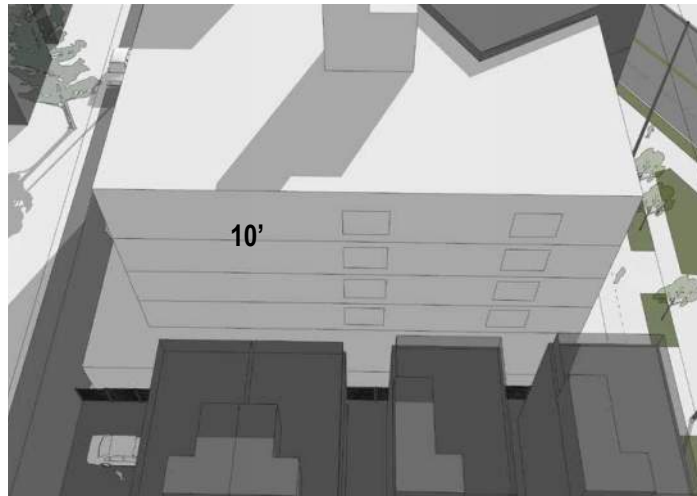

STUDY 1

Pro: Only 2 windows on north side and they could potentially line up with spaces between houses. Uniform 10' setback from side lot line.

Con: Uniform facade appears monolithic from townhouses.

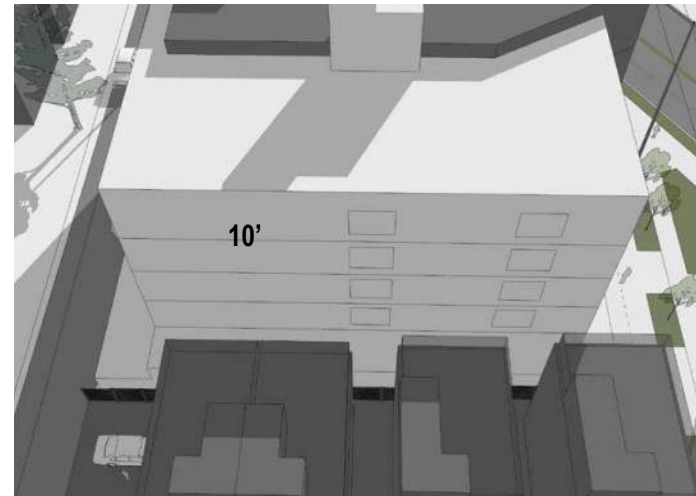

STUDY 2

Pro: Only 2 windows on north side and they could potentially line up with spaces between houses. Uniform 10' setback from side lot line.

Con: Uniform facade appears monolithic from townhouses.

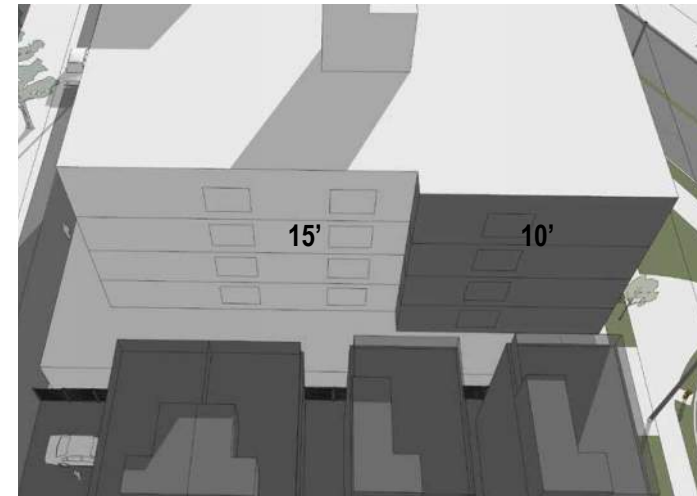

STUDY 3

Pro: Portion of facade set back at 10' and portion of facade set back at 15' allows for division of facade and 5' of extra space for 2 townhouses toward alley.

Con: 3 windows on each level adds to lack of privacy on this facade, but could be dealt with by minimizing size of window and carefully locating them.

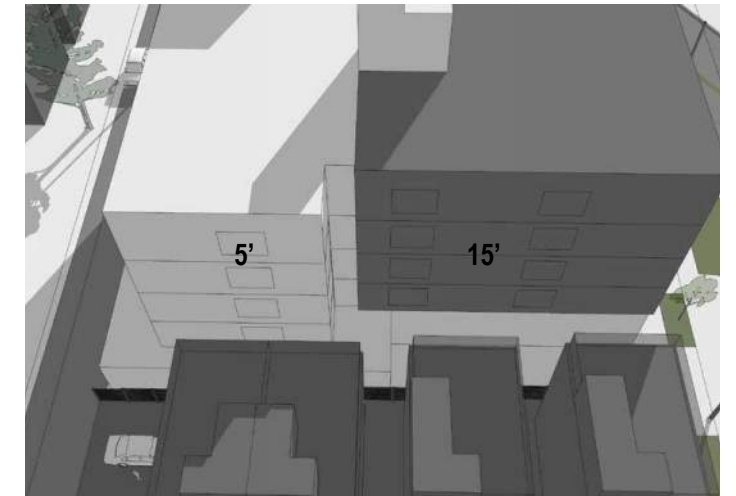

STUDY 4

Pro: Portion of facade set back at 5' and portion of facade set back at 15' allows for division of facade and 10' of extra space for 2 townhouses toward 18th Ave.

Con: 3 windows on each level adds to lack of privacy on this facade, but could be dealt with by minimizing size of window and carefully locating them. Only 5' of space for TH 3 and 4, but that space is minimized along the length.

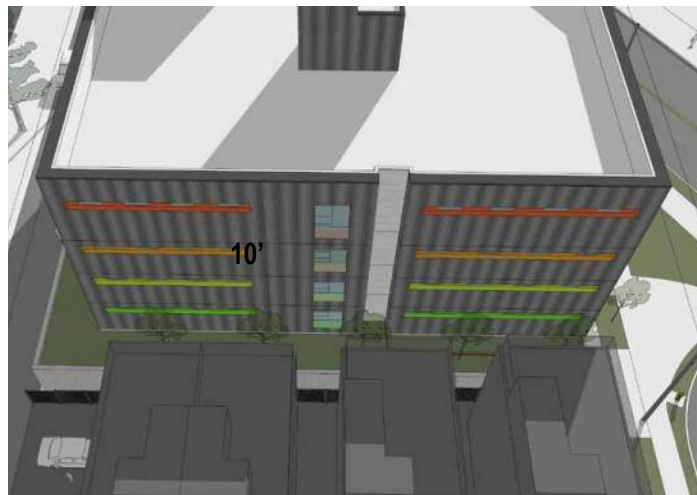

STUDY 5

Pro: Only full sized window on north facade is located in space between townhouses. Uniform 10' setback from property line.

Con: Some, but not much, articulation of north facade.

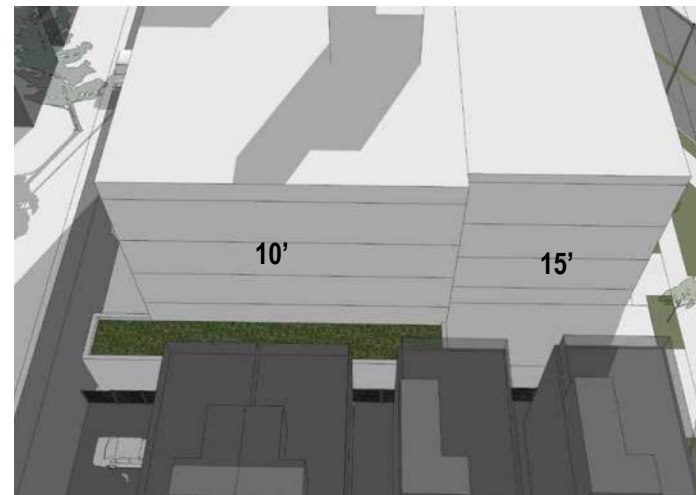

STUDY 6

Pro: Similar to Study 4

Con:

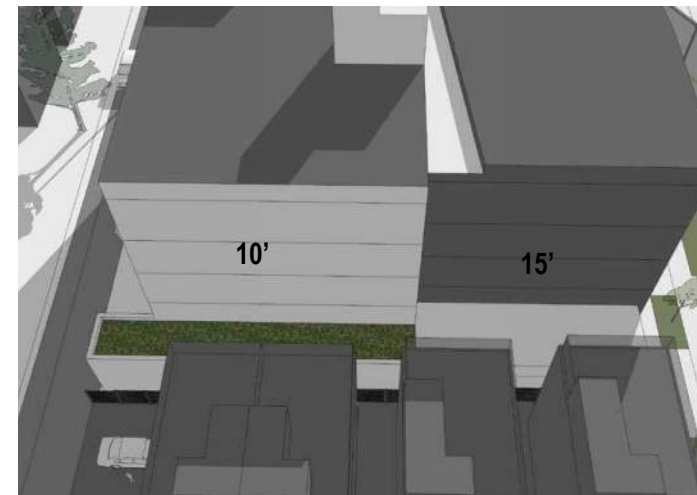

STUDY 7

Pro: Similar to Study 4

Con:

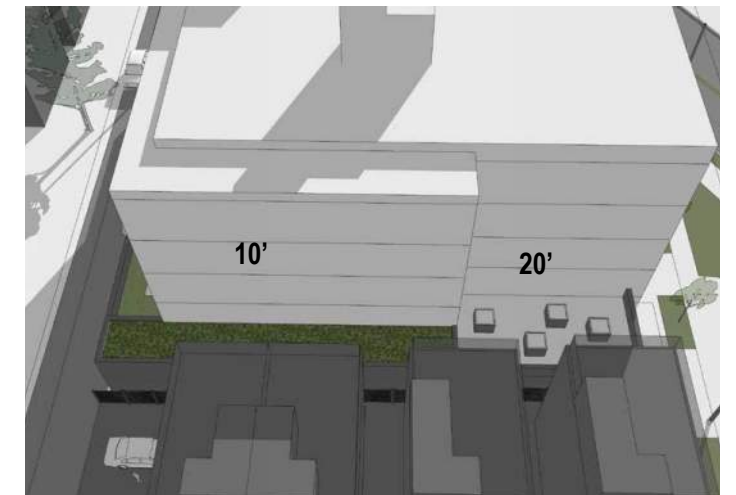

STUDY 8

Pro: Similar to Study 4

Con:

APPENDIX 1 | ADDITIONAL STUDIES

ISSUE 5: BLANK WALL



STUDY 1

Pro: No Blank Wall

Con:



STUDY 2

Pro: Minimizes units facing south lot line.

Con: Blank Wall takes up about half of south facade



STUDY 3

Pro: Blank Facade is only 23' x 40' and is same material as facade facing Delridge so it doesn't draw too much attention.

Con: Blank Facade



STUDY 4

Pro: Blank Facade is only 23' x 40' and is same material as facade facing Delridge so it doesn't draw too much attention.

Con: Blank Facade



STUDY 5

Pro: No Blank Wall

Con:



STUDY 6

Pro: Minimizes units facing south lot line.

Con: Blank Wall takes up about half of south facade (towards alley)



STUDY 7

Pro: Minimizes units facing south lot line.

Con: Blank Wall takes up about half of south facade (towards alley)



STUDY 8

Pro: No Blank Wall

Con: No differentiation or articulation along south wall.

APPENDIX 1 | ADDITIONAL STUDIES

ISSUE 5: BLANK WALL



STUDY 1

Pro: No Blank Wall

Con:



STUDY 2

Pro: Minimizes units facing south lot line.

Con: Blank Wall takes up about half of south facade



STUDY 3

Pro: Blank Facade is only 23' x 40' and is same material as facade facing Delridge so it doesn't draw too much attention.

Con: Blank Facade



STUDY 4

Pro: Blank Facade is only 23' x 40' and is same material as facade facing Delridge so it doesn't draw too much attention.

Con: Blank Facade



STUDY 5

Pro: No Blank Wall

Con:



STUDY 6

Pro: Minimizes units facing south lot line.

Con: Blank Wall takes up about half of south facade (towards alley)



STUDY 7

Pro: Minimizes units facing south lot line.

Con: Blank Wall takes up about half of south facade (towards alley)



STUDY 8

Pro: No Blank Wall

Con: No differentiation or articulation along south wall.

APPENDIX 1 | ADDITIONAL STUDIES

ISSUE 6: SOLAR EXPOSURE

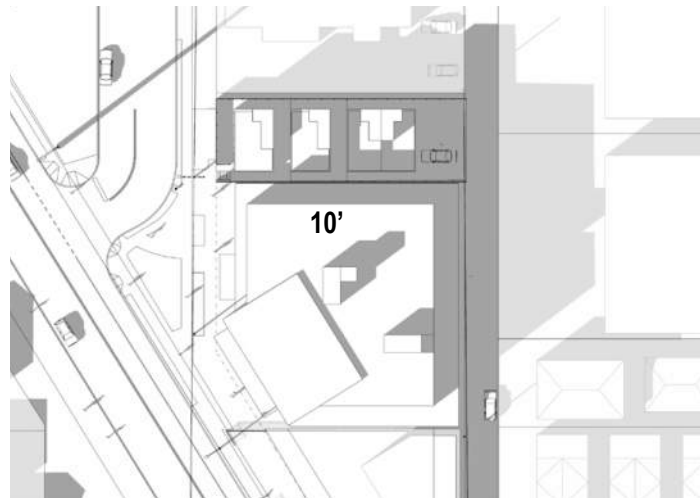

STUDY 1

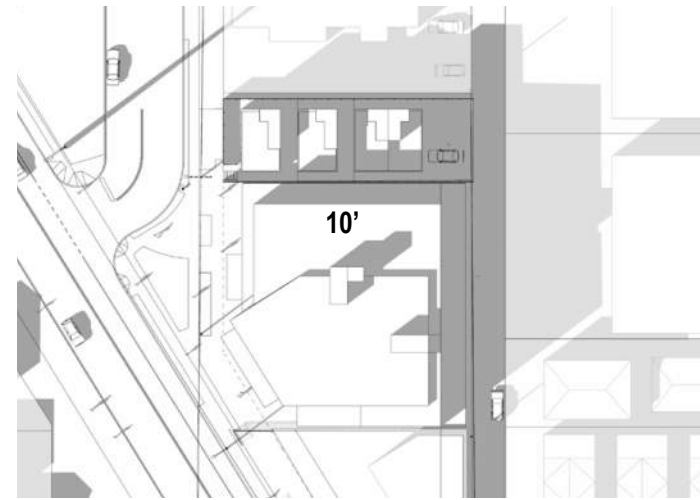

STUDY 2

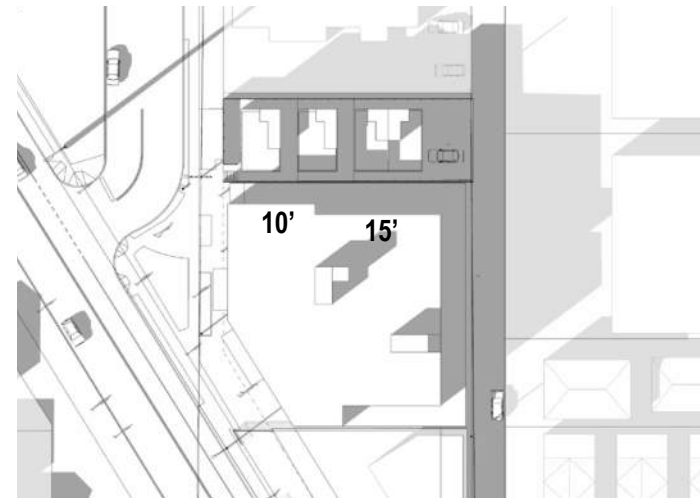

STUDY 3

Slightly better than Study 1 and 2 for TH 4

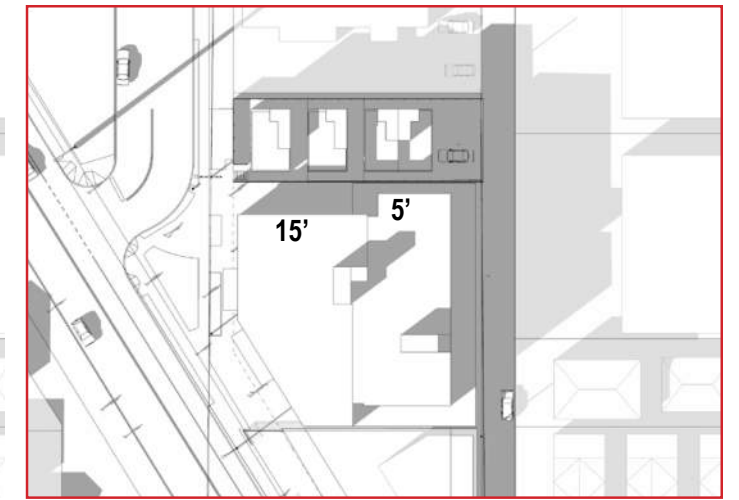

STUDY 4

The best option of the 8.

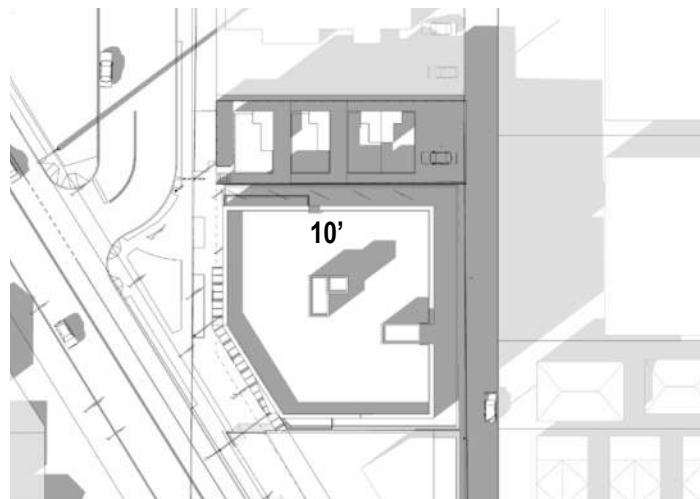

STUDY 5

Similar to Study 1 and 2

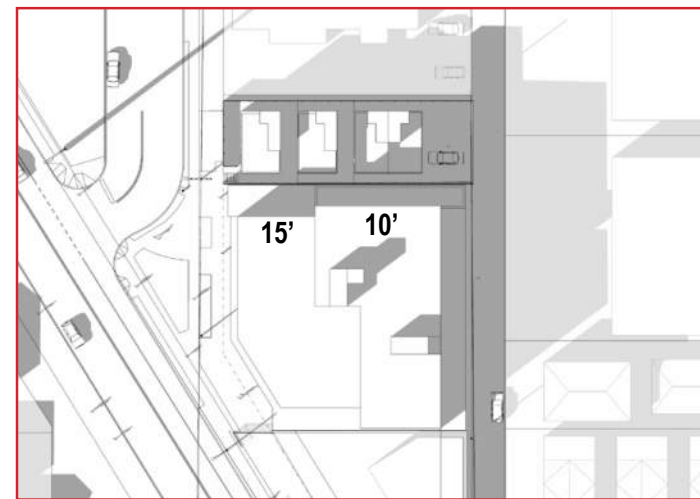

STUDY 6

Better for TH 2.

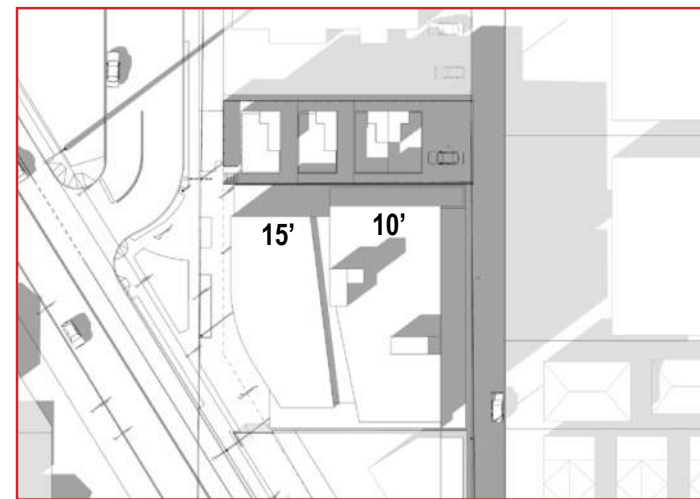

STUDY 7

Better for TH 2.

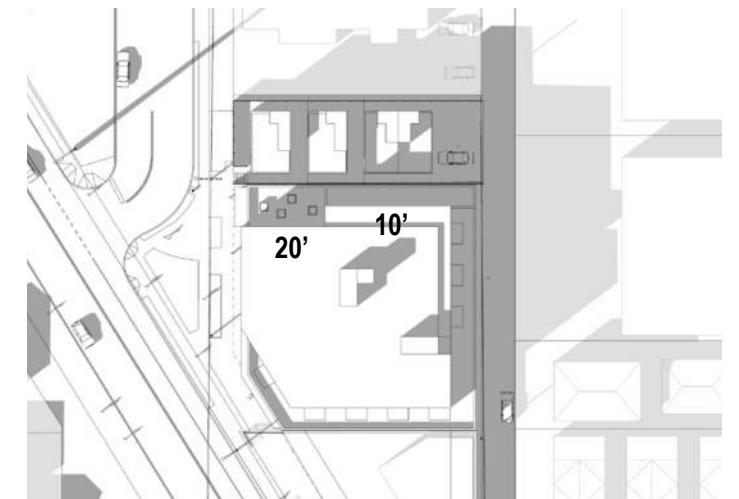

STUDY 8

Setting back 20' from property line doesn't appear to help significantly.

APPENDIX 1 | ADDITIONAL STUDIES

ISSUE 7 & 8: FLEXIBLE GROUND LEVEL PLAN THAT RETAINS STRONG CONNECTION TO THE PUBLIC REALM & STREETScape PEDESTRIAN CONNECTIVITY ATMOSPHERE, SPILLOVER ACTIVITY



STUDY 1

Pro: Commercial facade is naturally divided into 2 smaller sections that would be conducive for smaller commercial.

Con: Less flexibility of commercial frontage



STUDY 2

Pro: Commercial facade is naturally divided into 2 smaller sections that would be conducive for smaller commercial.

Con: Less flexibility of commercial frontage



STUDY 3

Pro: Commercial facade is continuous which could lend itself to flexible space.

Con: No hierarchy along commercial frontage. Residential entry is very large



STUDY 4

Pro: Commercial facade is continuous which could lend itself to flexible space. Residential entrance is more in scale with the size of the building and is pulled away from TH to north

Con: No hierarchy along commercial frontage. Is the space between TH and Residential entry a dead space??



STUDY 5

Pro: Commercial facade is continuous which could lend itself to flexible space.

Con: No hierarchy along commercial frontage.



STUDY 6

Pro: Commercial facade is continuous which could lend itself to flexible space.

Con: Residential entry looks small and squashed between Commercial frontage and TH to north.



STUDY 7

Pro: Commercial facade is continuous which could lend itself to flexible space.

Con: Residential entry looks small and squashed between Commercial frontage and TH to north.



STUDY 8

Pro: Commercial facade is naturally divided into 2 smaller sections that would be conducive for smaller commercial. Residential entry is a nice scale and differentiated from Commercial frontage.

Con: "Middle" Commercial frontage seems large and may be hard to subdivide.

Appendix 2:
EDG 1 Materials

6.0 ZONING DATA

ZONE: NC3-55

URBAN VILLAGE: WESTWOOD-HIGHLAND PARK RESIDENTIAL

APPLICABLE ZONING	SMC-SECTION	SUB-SECTION	REQUIREMENT	OPTION 1	OPTION 2	OPTION 3 (PREFERRED)
Uses Permitted	23.47A.004	Table A	Eating and Drinking Establishments, Office, Sales and Service, Live Work Units, Residential Uses, Lodging: Permitted	√	√	√
Street-Level Uses	23.47A.005	C.1 & D.1	The site is located at the edge of the designate 'pedestrian-designated zone' immediately to the south. Eating & Drinking, entertainment, hotels, offices, parks, retail, & sales, are allowed. Residential is also allowed.	√	√	√
Street-Level Development Standards	23.47A.008	A.1	Applies for structures in NC-zones	√	√	√
		A.2.b	Blank street facing facades between 2 feet & 8 feet shall not be more than 20 feet in length	√	√	√
		A.2.c	Total blank facades shall not exceed 40% of the width of the street facing facade of the structure	√	√	√
		A.3	Street level, street facing facades shall be within 10 of the street property line, unless wider sidewalks, plazas, or other approved spaces are provided.	√	√	√
		B.2.a	60% of street facing facades between 2 feet & 8 feet shall be transparent	√	√	√
		B.3.a	Non-residential uses > 600 SF shall extend an average depth of at least 30 feet and a minimum depth of 15 feet from the street-level stree-facing facade	√	√	√
		B.4	Non-residential uses at street level shall have a floor-to-floor height of at least 13 feet	√	√	√
E.2	Each live-work unit must have a pedestrian entry on the street-facing facade that is designed to be visually prominent and provide direct access to the non-residential portions of the unit.	√	√	√		
Structure Height	23.47A.012	A	55 feet	√	√	√
Floor Area Ratio	23.47A.013	Table A	FAR limit outside Station Area Overlay District: 3.75	√	√	√
Landscaping	23.47A.016	A.2	Green factor of 0.3 required	√	√	√
		B.1	Street Trees are required	√	√	√
Light and Glare Standards	23.47A.022	A	Exterior lighting must be shielded and directed away from adjacent uses	√	√	√
		B	Interior lighting in parking garages must be shielded to minimize nighttime glare affecting nearby uses	√	√	√
Amenity Area	23.47A.024	A	Amenity areas are required in an amount equal to 5 percent of the total gross floor area in residential use, except as otherwise specifically provided in this Chapter 23.47A.	√	√	√
		B	All residents shall have access to at least one common or private amenity area. Amenity areas shall not be enclosed. Common amenity area shall have a minimum horizontal dimension of 10 feet, and be no less than 250 SF. Private balconies and decks shall have a minimum area of 60 SF and no horizontal dimension less than 6 feet.	√	√	√
Required Parking	23.54.015	Table A, K	Non-residential uses in urban villages that are not within an urban center or the Station Area Overlay District, if the non-residential use is located within a frequent transit service area. = No minimum requirement	√	√	√
		Table B, M	All residential uses in commercial, RSL and multifamily zones within urban villages that are not within urban center or the Station Area Overlay District, if the residential use is located within a frequent transit service area. = No minimum requirement	√	√	√
Required Bicycle Parking	23.54.015	Table D, A.1	Eating and drinking establishments: Long-term = 1 per 5,000 sf, Short-term = 1 per 1,000 sf (Required spaces: 1 long-term, 6 short-term; or General Sales: Long Term = 1 per 4,000 sf & 1 per 2,000sf (Required spaces: 2 long-term, 6 short-term; Provided spaces: 1 long-term, 6 short-term) Multi-family structures: Long-term = 1 per dwelling unit, Short-term = 1 per 20 dwelling units (Required spaces: 59 long-term, 4 short-term; Provided spaces: 59 long-term, 4 short-term [Option 3])	√	√	√
Trash Storage	23.54.040	Table A	Residential development: 51-100 dwelling units = Minimum of 375 sf + 4 sf for each additional unit above 50 = 411sf Non-residential development: (5,300SF provided) 5,001-15,000sf = Minimum of 125sf, but 50% = 63sf (see B below) [Total minimum required: 474 sf; Provided: 557 sf (Option 3)]	√	√	√
		B	Mixed use development that contains both residential and non-residential uses shall meet the storage space requirements shown in Table A for 23.54.040 for residential development, plus 50 percent of the requirement for non-residential development. In mixed use developments, storage space for garbage may be shared between residential and non-residential uses, but separate spaces for recycling shall be provided.	√	√	√
		E	Trash storage shall not be between building and the street	√	√	√

APPENDIX 2 | EDG 1 OPTION 1

DESIGN PART I - ORIENT TO DELRIDGE

The building's mass can be thought as two intersecting volumes: the larger one sits toward the alley and the smaller one aligns with Delridge Way SW. This helps to create more articulation of the mass toward 18th Ave SW and a strong urban edge on Delridge where future development is expected to occur. Further setbacks of the larger mass and variations in roofline reinforce the smaller mass's significance along Delridge.

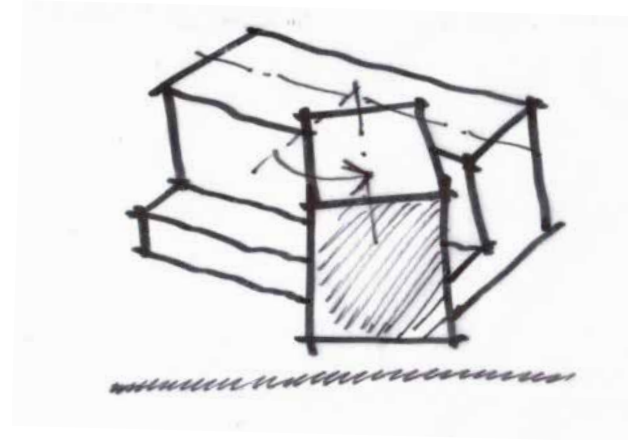

DESIGN PROCESS

STEP 1: BUILD TO ZONING ENVELOPE

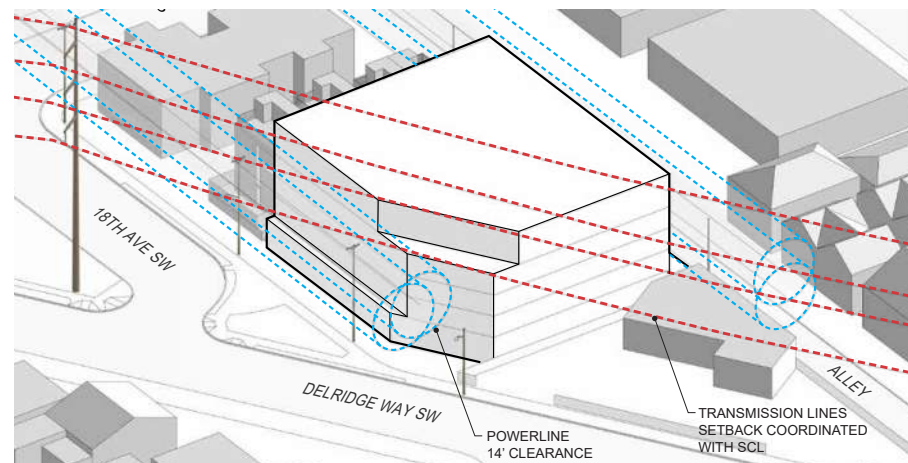

STEP 4: CREATE RECESSES TO RELATE TO TOWNHOME SCALE

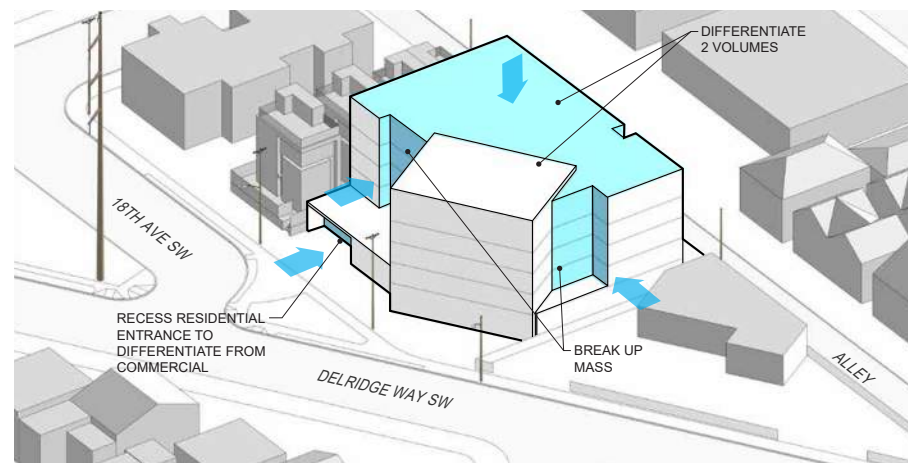

STEP 2: CREATE GENERAL MASSING RELIEF

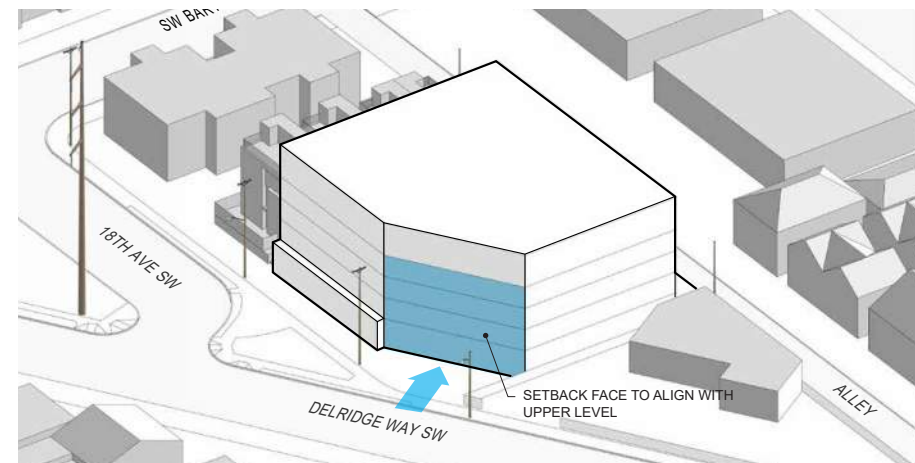

STEP 5: FURTHER ARTICULATION

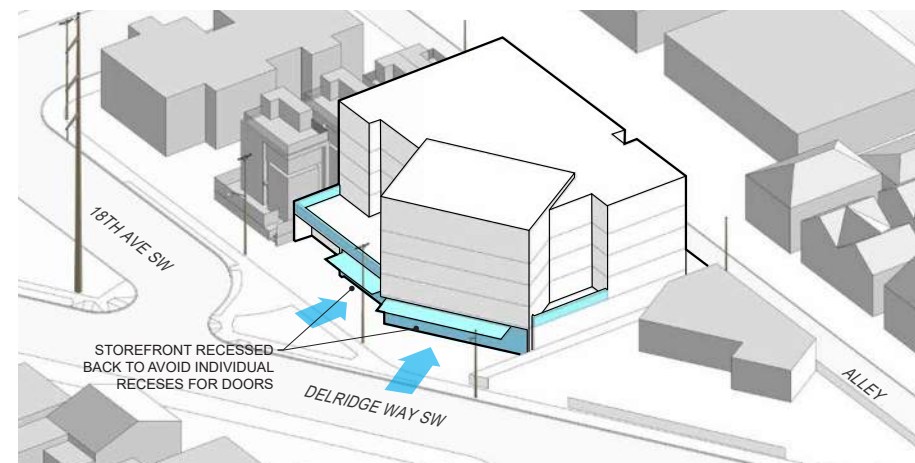

STEP 3: FURTHER MASSING REFINEMENT

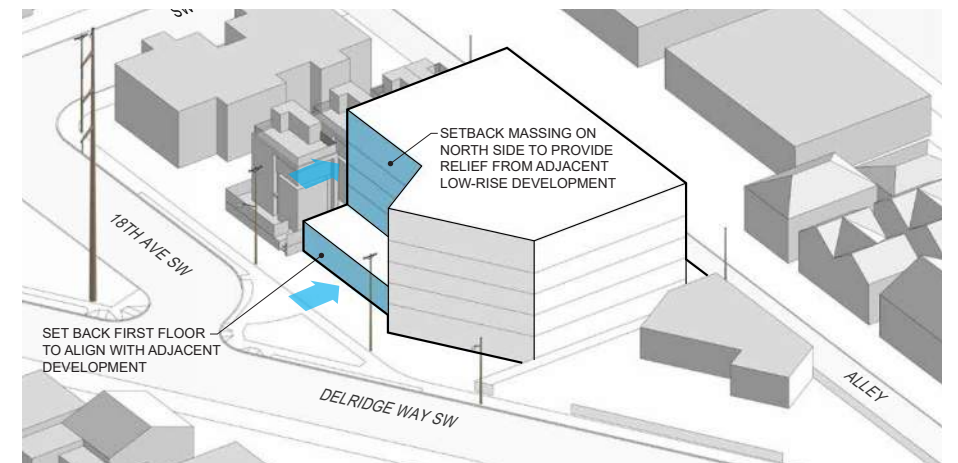

APPENDIX 2 | EDG 1 OPTION 1

DESIGN INSPIRATION



①

DC2.A: MASSING

5-stories without any setbacks is oriented to create a strong urban frontage. It can be expressed with varying reveals and window placement for visual interest. It does not respond to the scale of the neighborhood, however.



②



③

PL1.C: OUTDOOR USES AND ACTIVITIES

Glazing, weather protection, and outdoor elements helps transform this sidewalk into an active pedestrian space.

FINAL CONCEPT MASSING

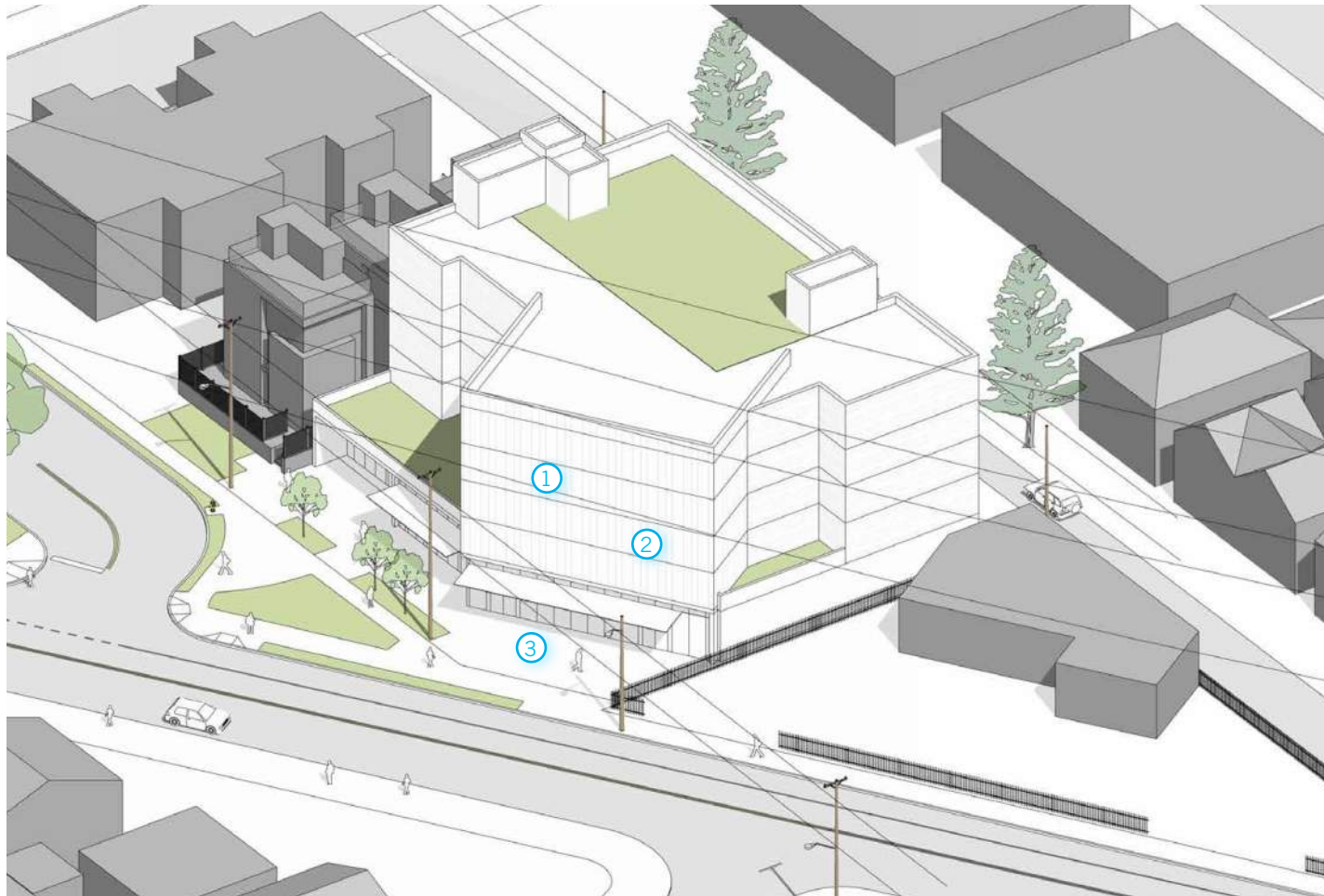

AXONOMETRIC VIGNETTE FROM SOUTHWEST

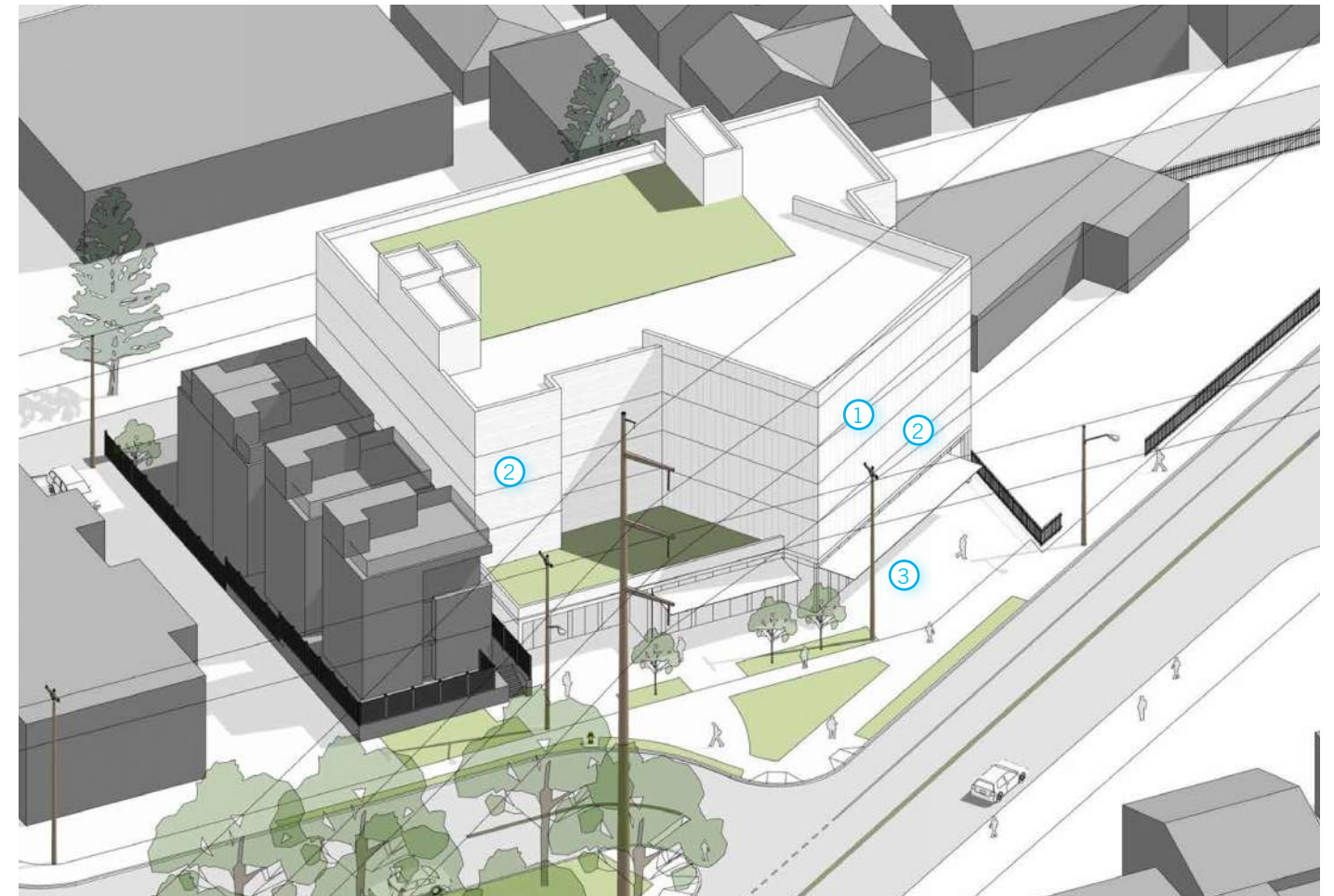

AXONOMETRIC VIGNETTE FROM NORTHWEST

APPENDIX 2 | EDG 1 OPTION 1

DESIGN ANALYSIS

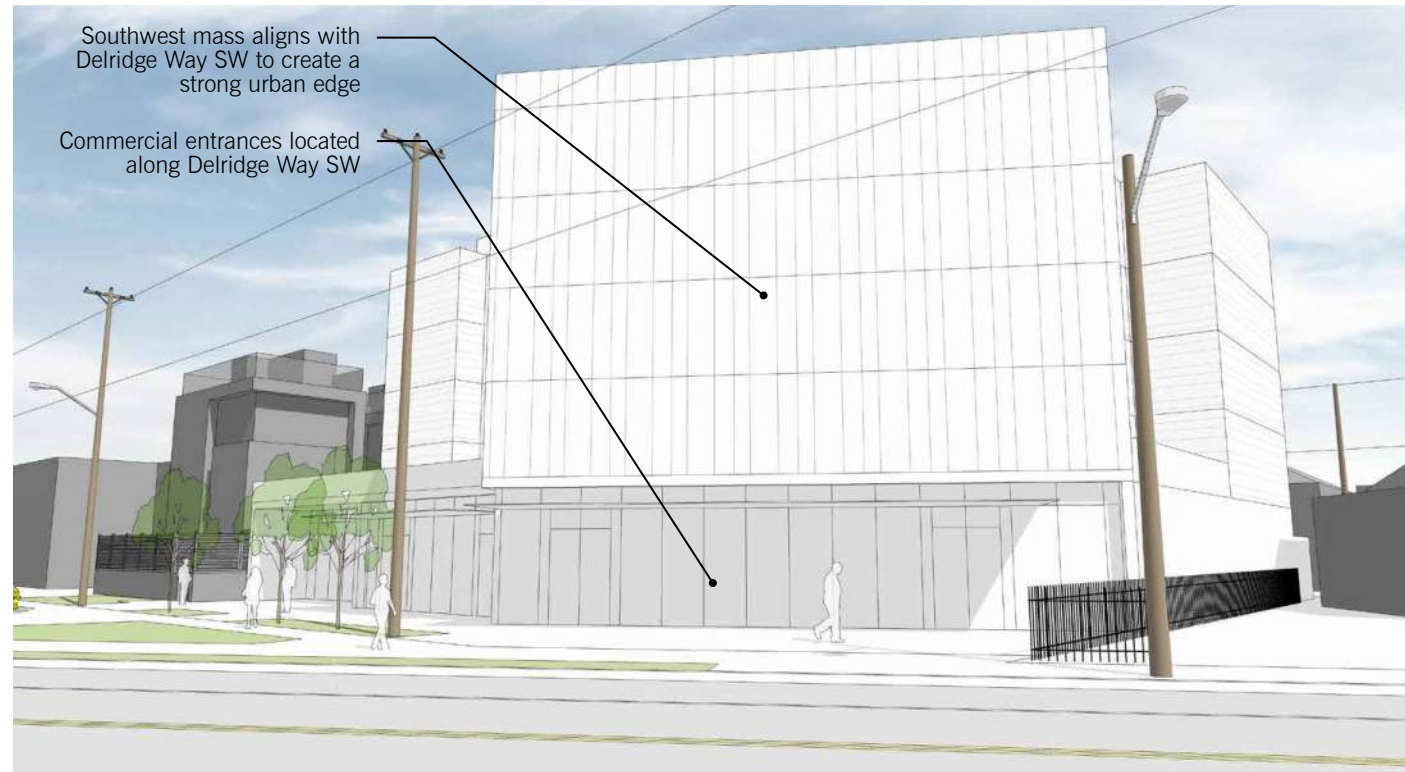

VIEW FROM DELRIDGE WAY SW

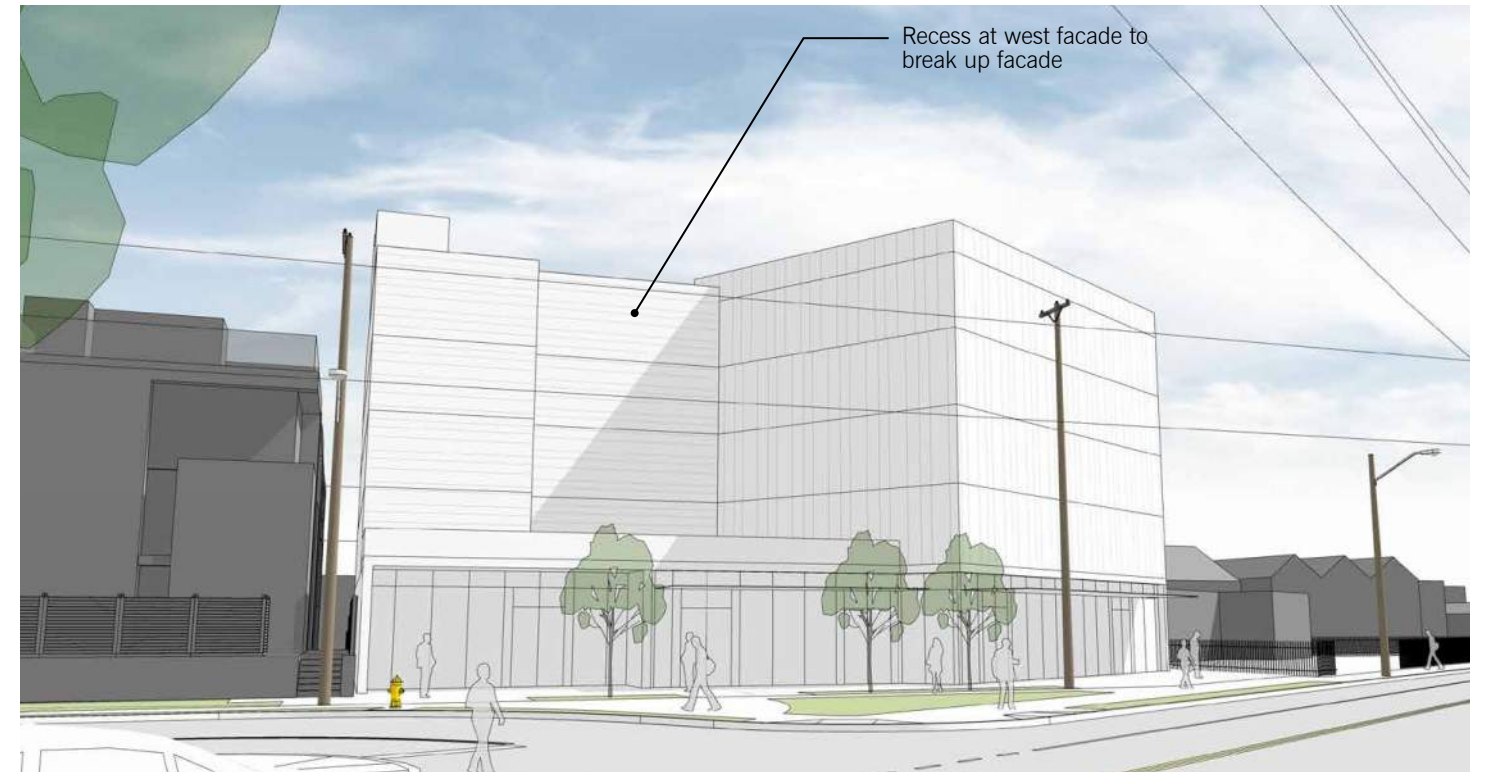

VIEW FROM DELRIDGE WAY SW AND 18TH AVE SW

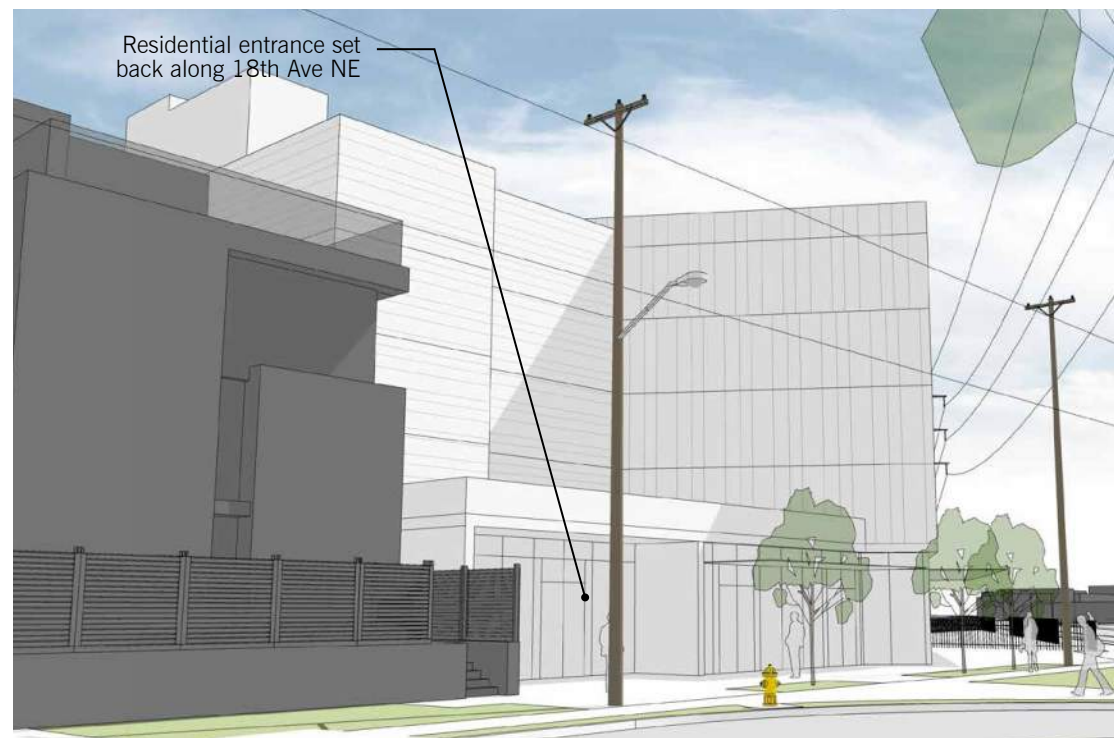

VIEW FROM 18TH AVE SW

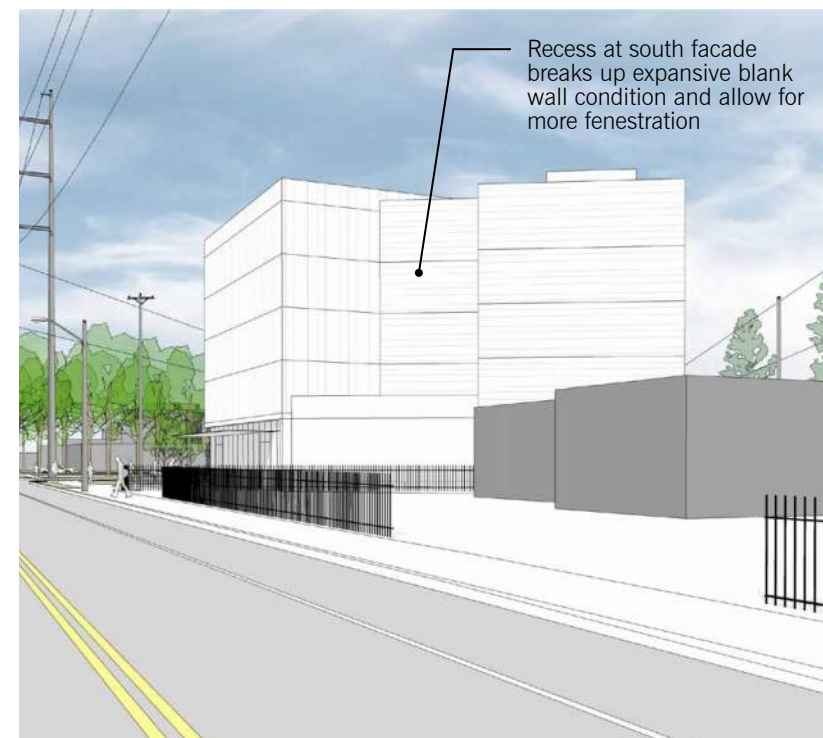

VIEW FROM DELRIDGE WAY SW LOOKING NORTH

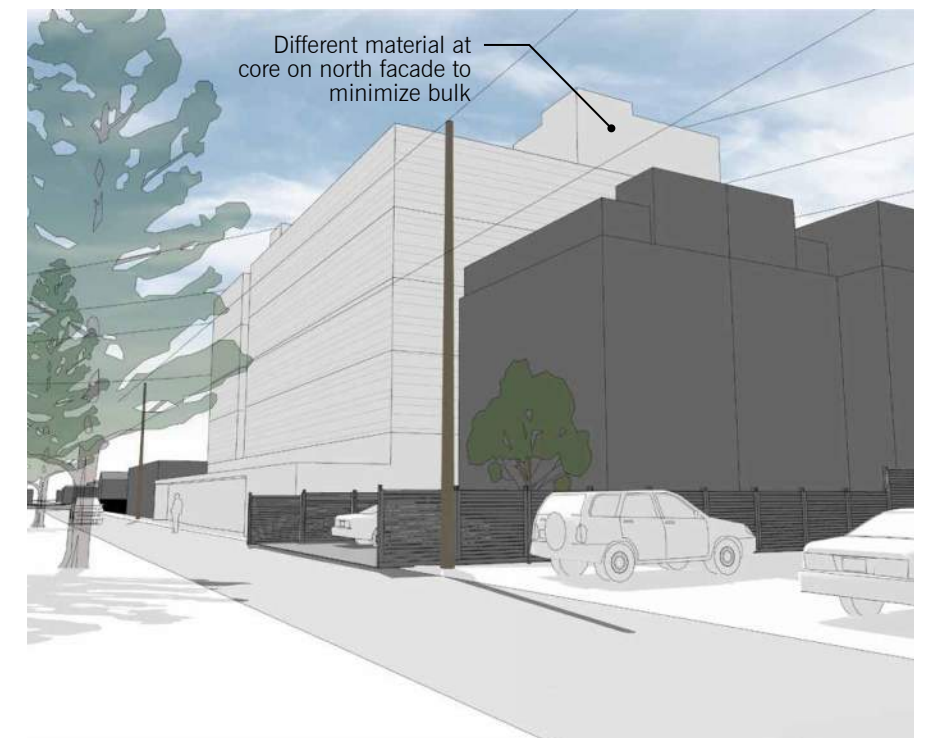

VIEW FROM ALLEY LOOKING SOUTH

APPENDIX 2 | EDG 1 OPTION 1



AERIAL VIEW FROM SOUTHWEST

APPENDIX 2 | EDG 1 OPTION 1



AERIAL VIEW FROM NORTHWEST

APPENDIX 2 | EDG 1 OPTION 1

KEY

- Commercial
- Planting Strip
- Residential
- Residential Amenity
- Utility/BOH
- Parking/Garage
- Circulation
- Balcony

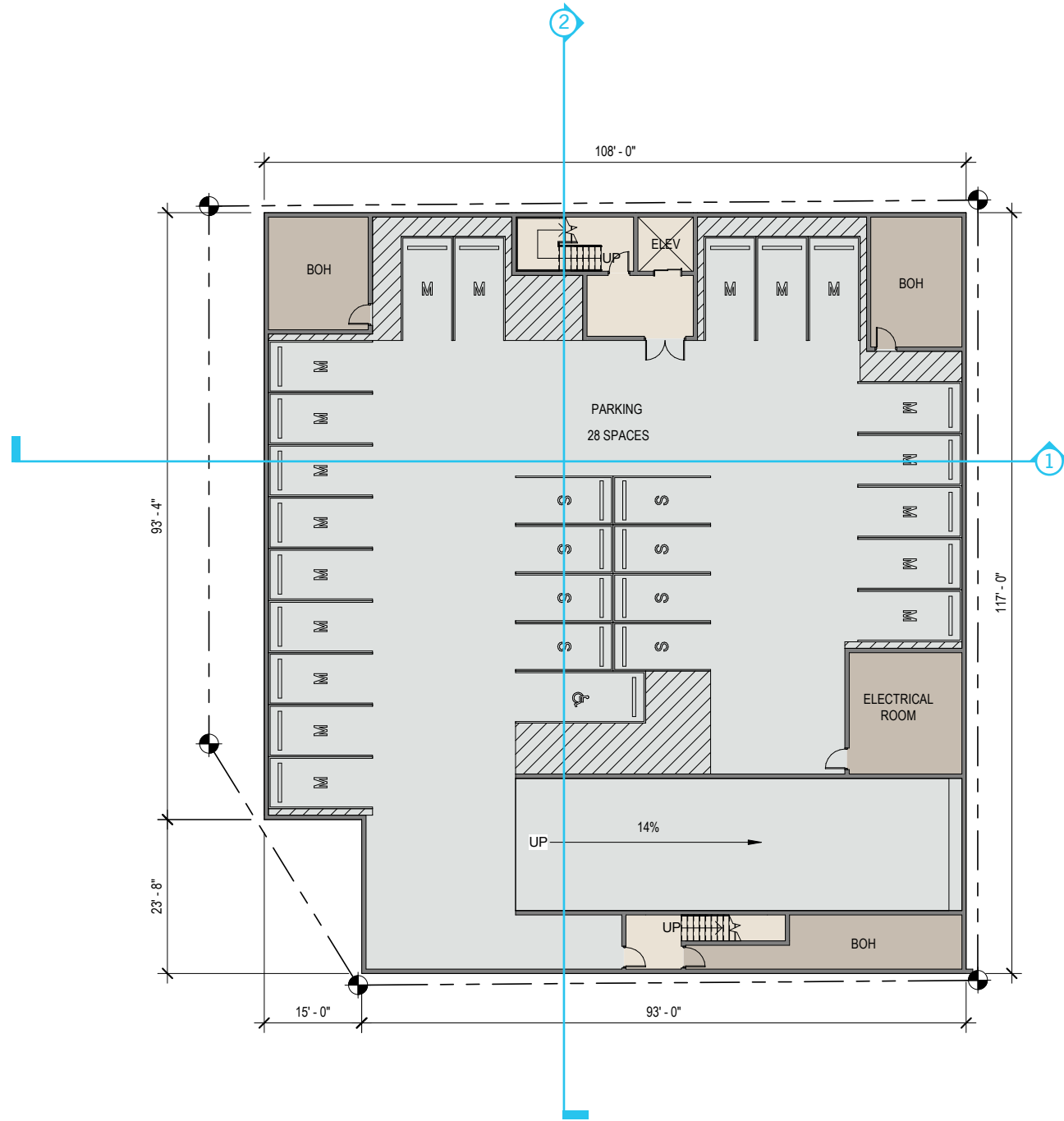

LEVEL P1

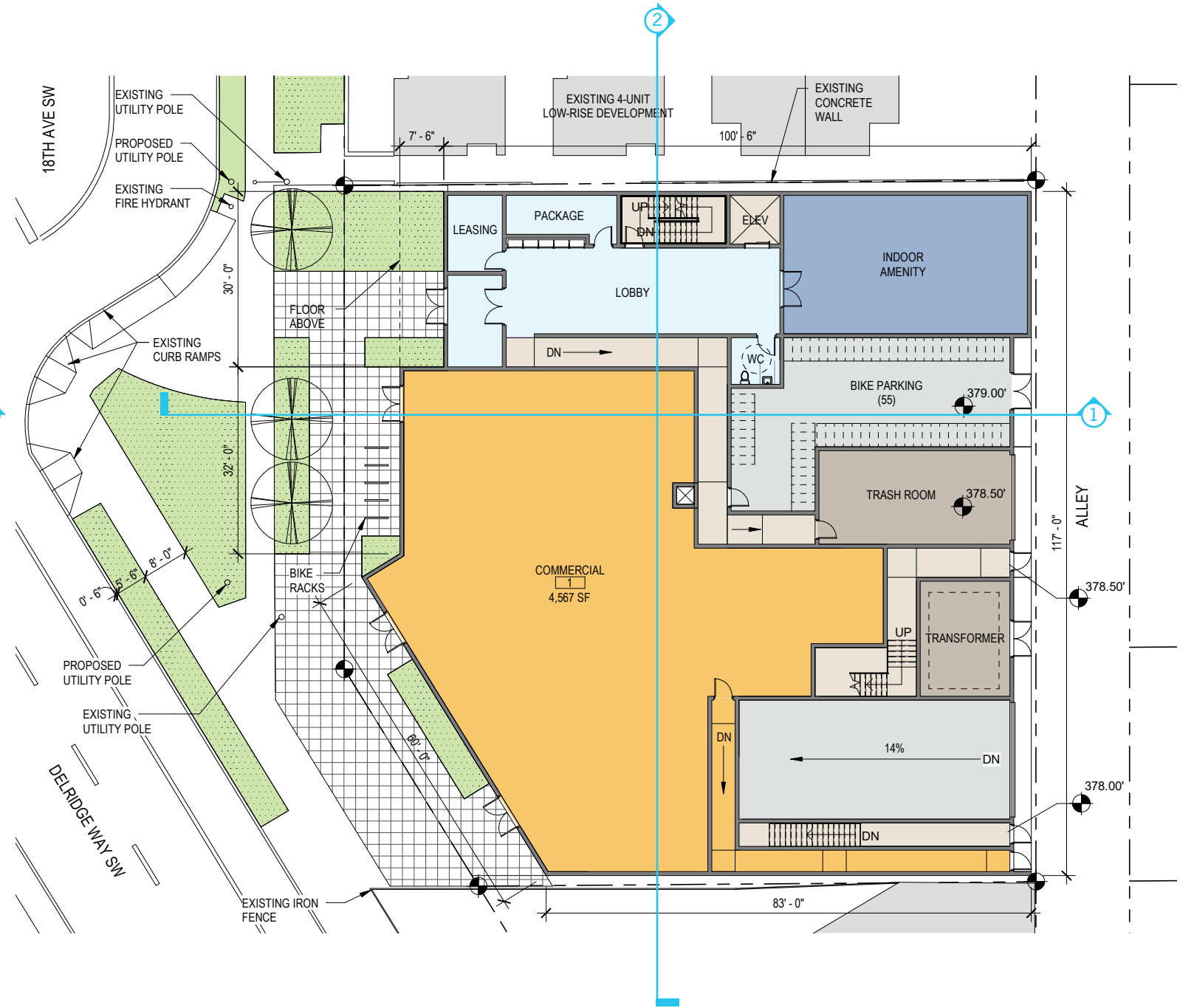

LEVEL 1



APPENDIX 2 | EDG 1 OPTION 1

KEY

- Commercial
- Planting Strip
- Residential
- Residential Amenity
- Utility/BOH
- Parking/Garage
- Circulation
- Balcony

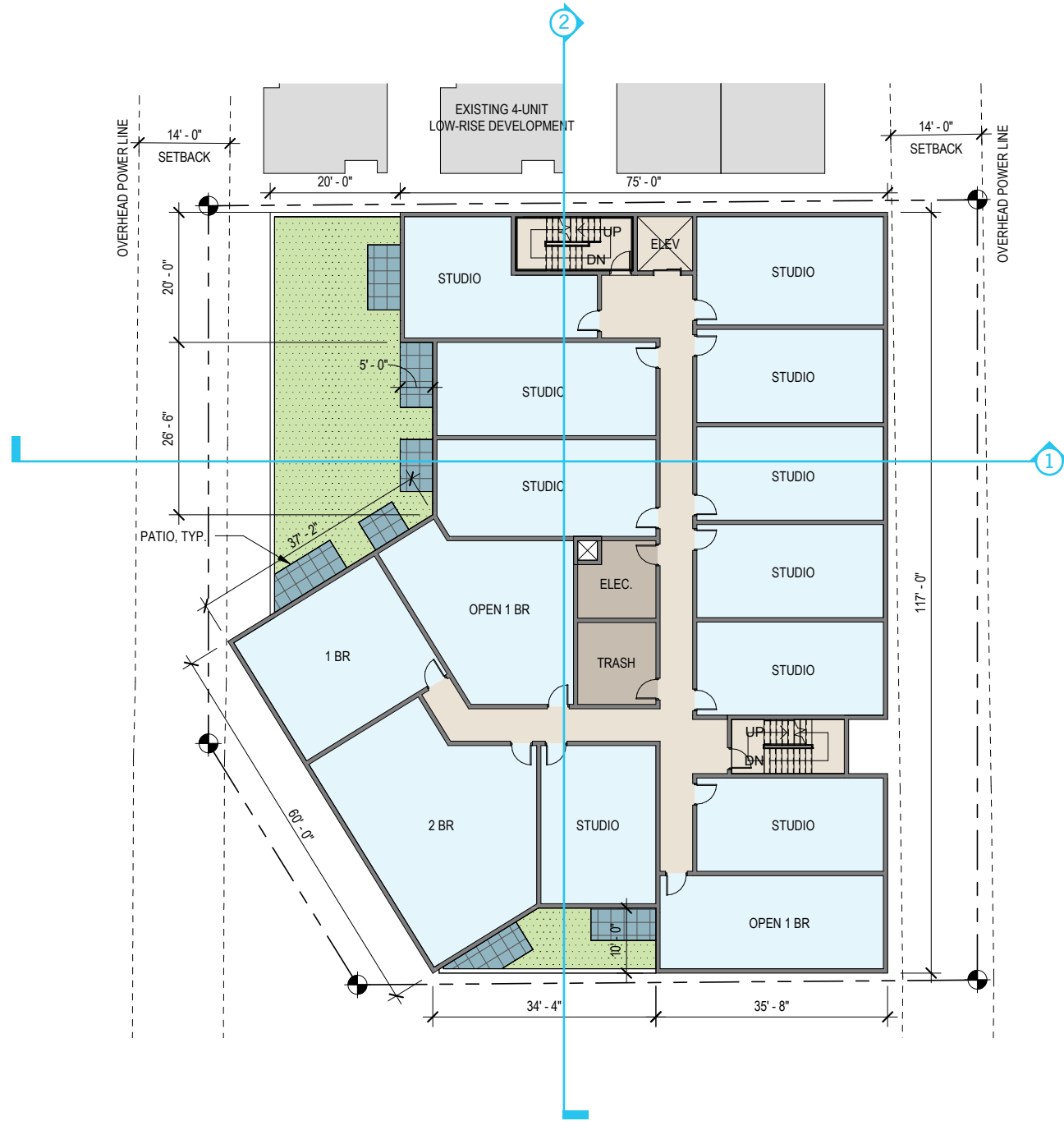

LEVEL 2

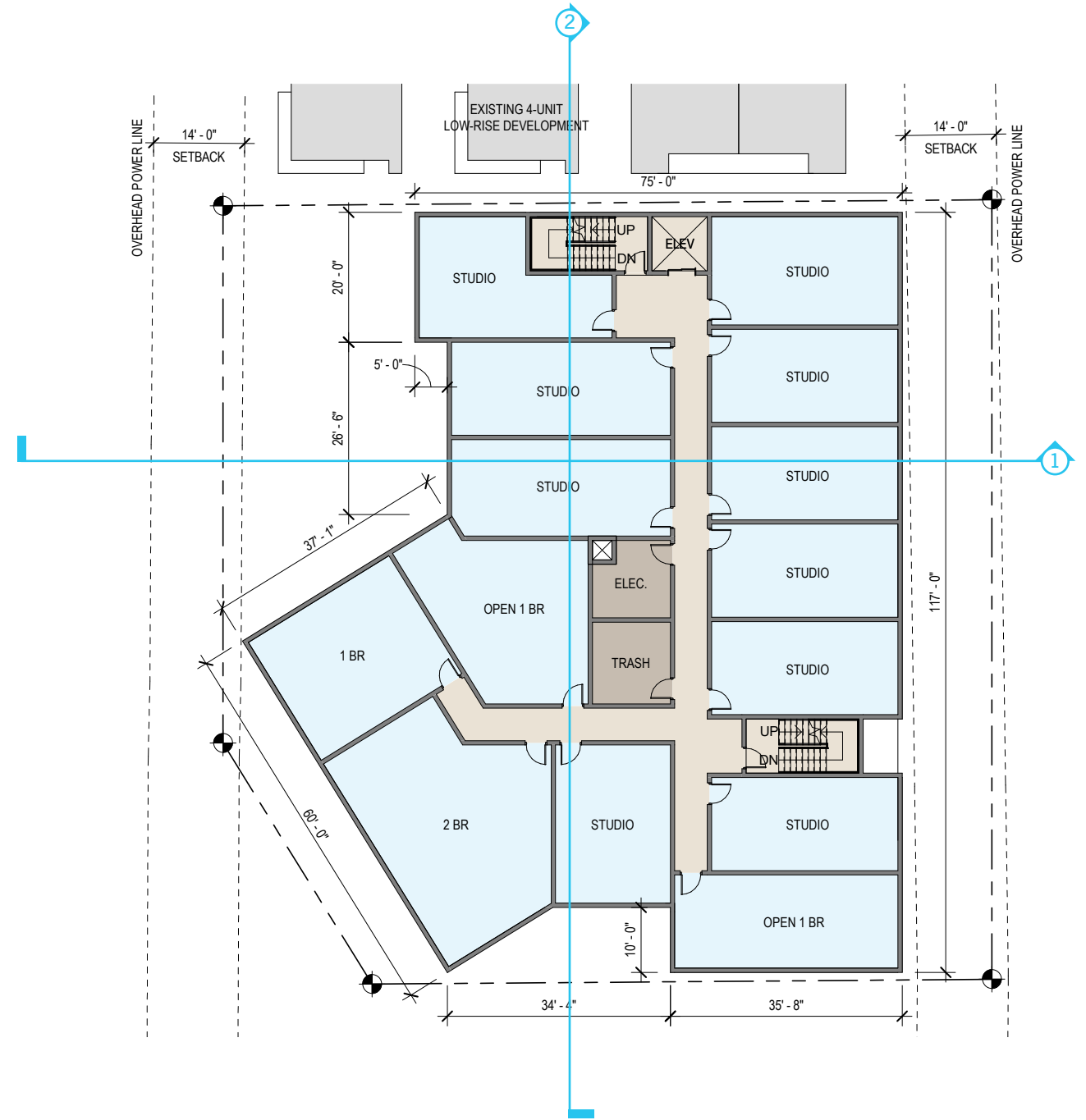

LEVEL 3-4



APPENDIX 2 | EDG 1 OPTION 1

KEY

- Commercial
- Planting Strip
- Residential
- Residential Amenity
- Utility/BOH
- Parking/Garage
- Circulation
- Balcony

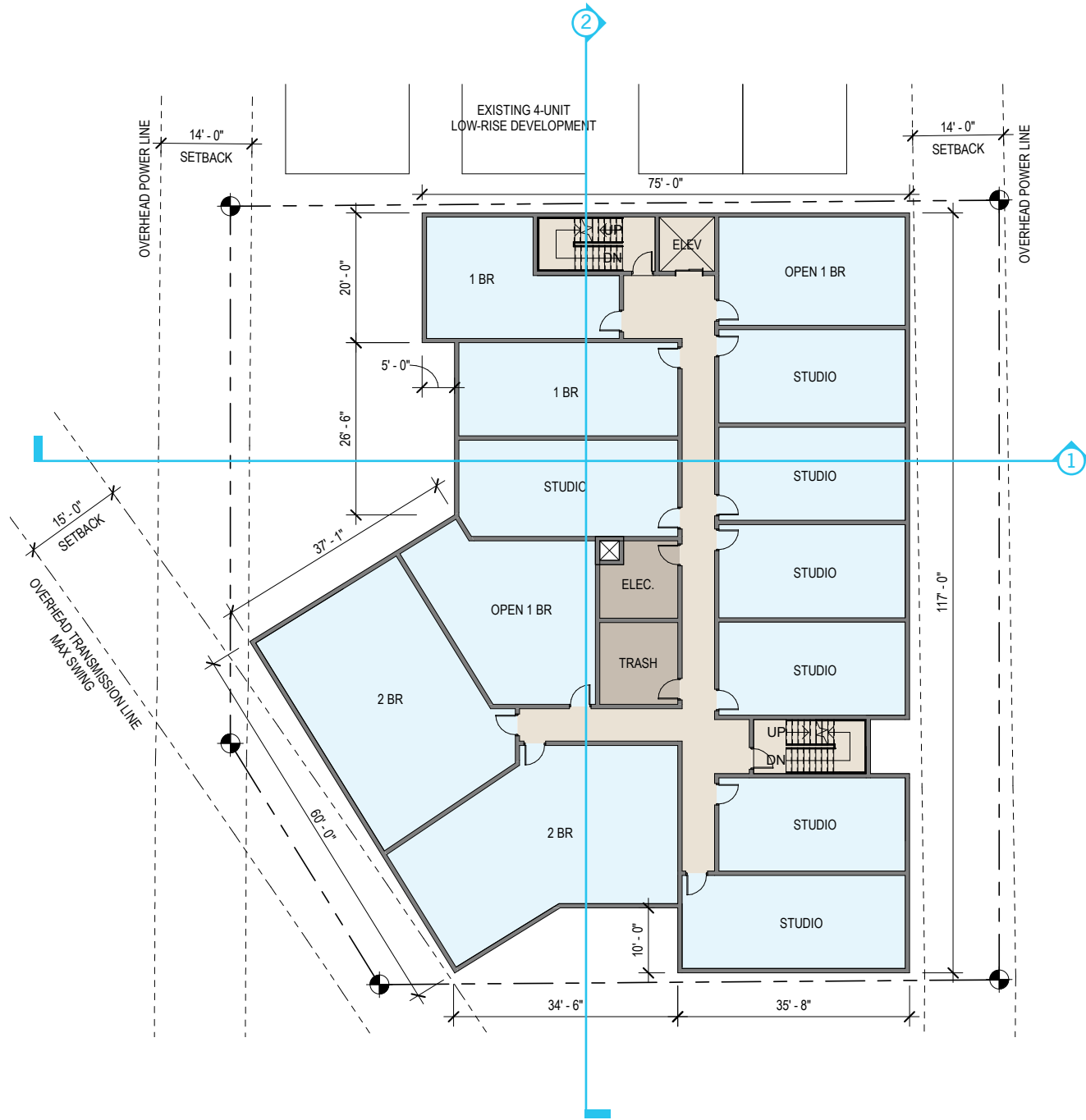

LEVEL 5

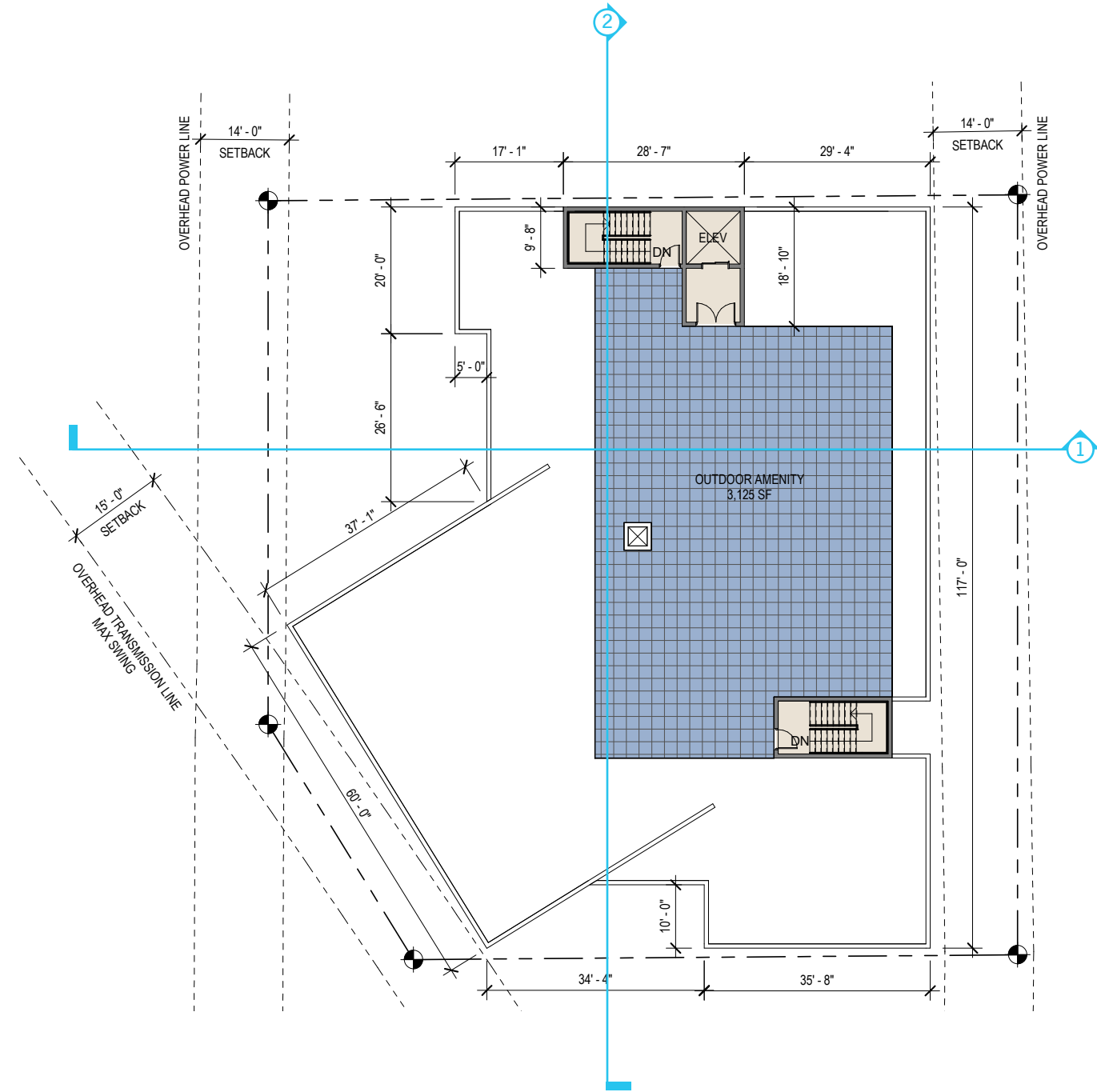

ROOF



APPENDIX 2 | EDG 1 OPTION 1

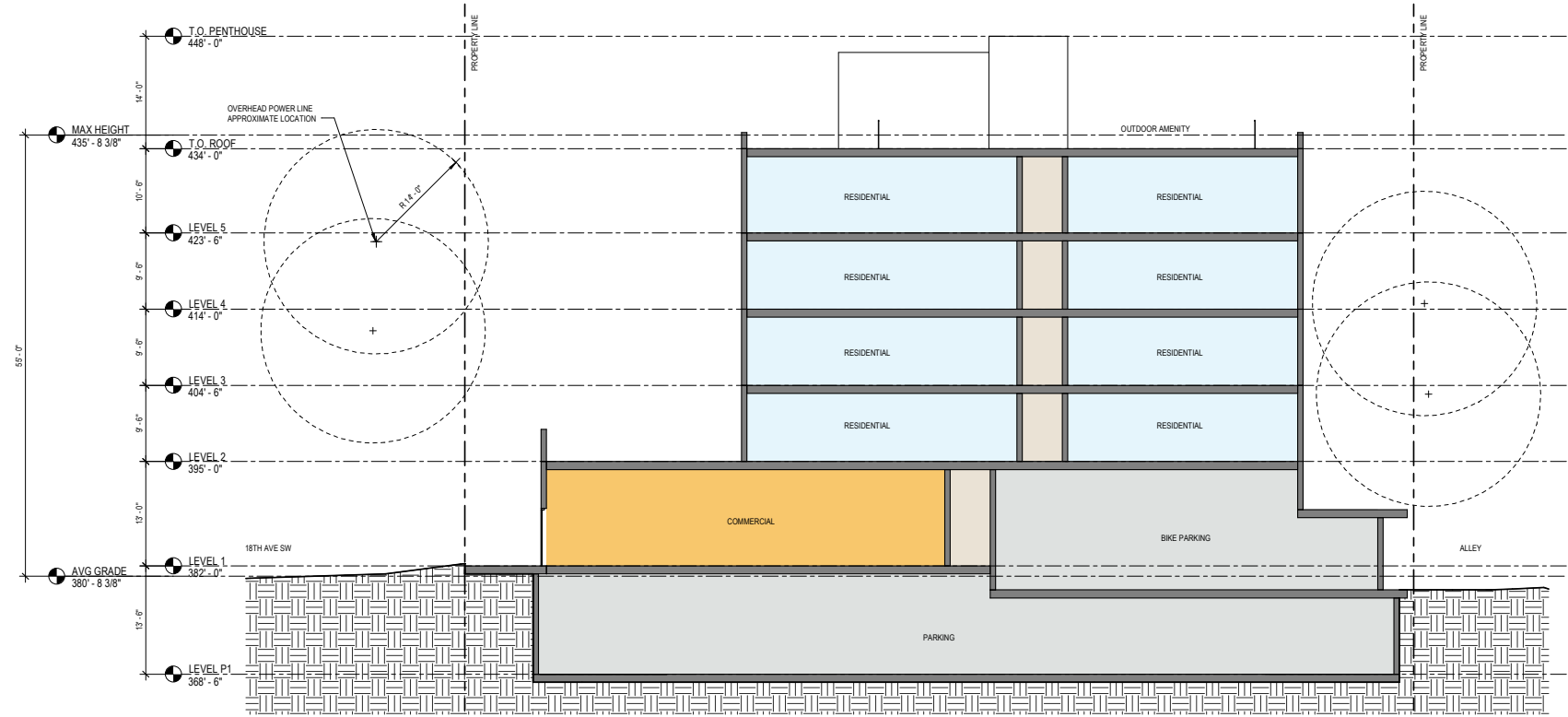

SECTION 1

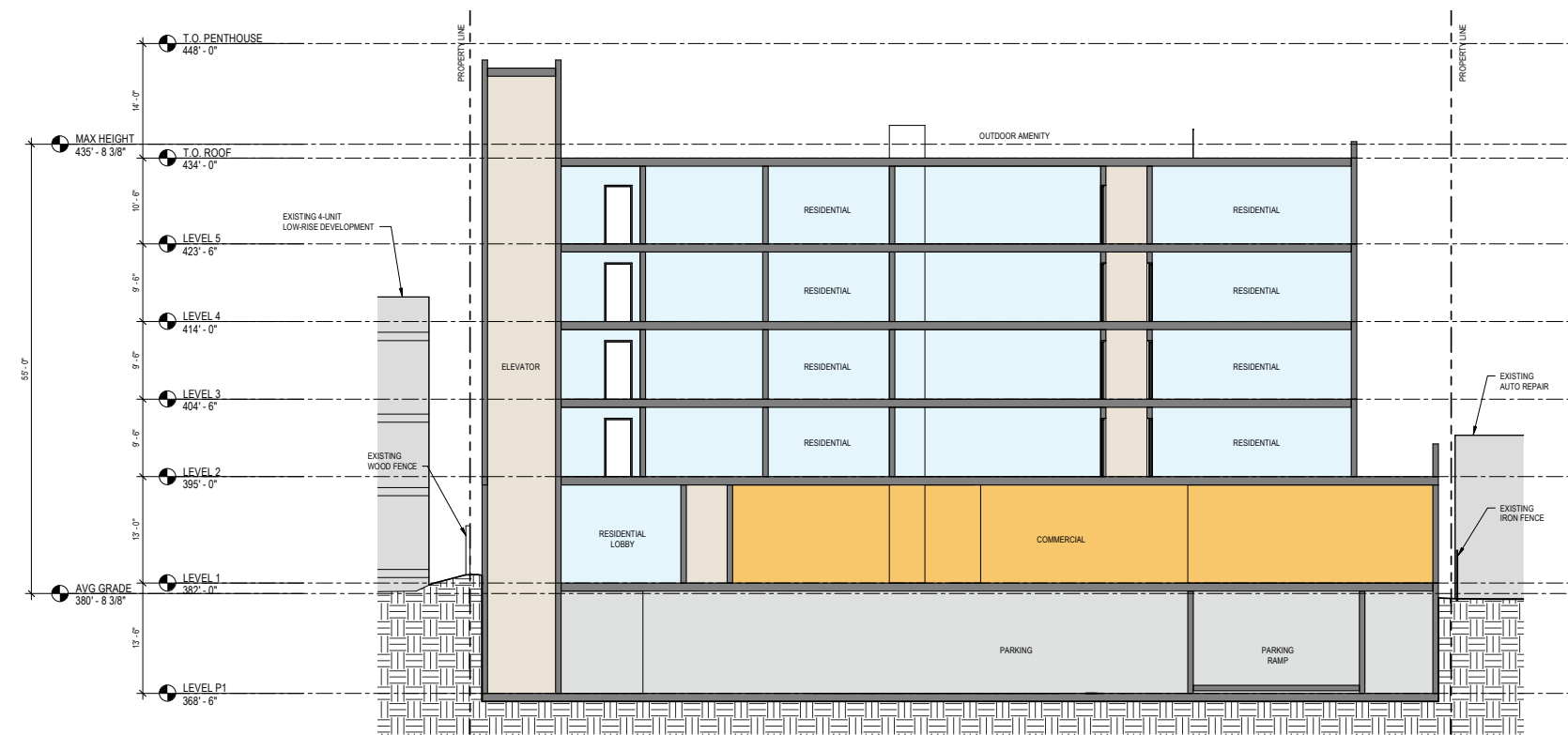

SECTION 2

- KEY**
- Commercial
 - Residential
 - Utility/BOH
 - Circulation
 - Parking

APPENDIX 2 | EDG 1 OPTION 1

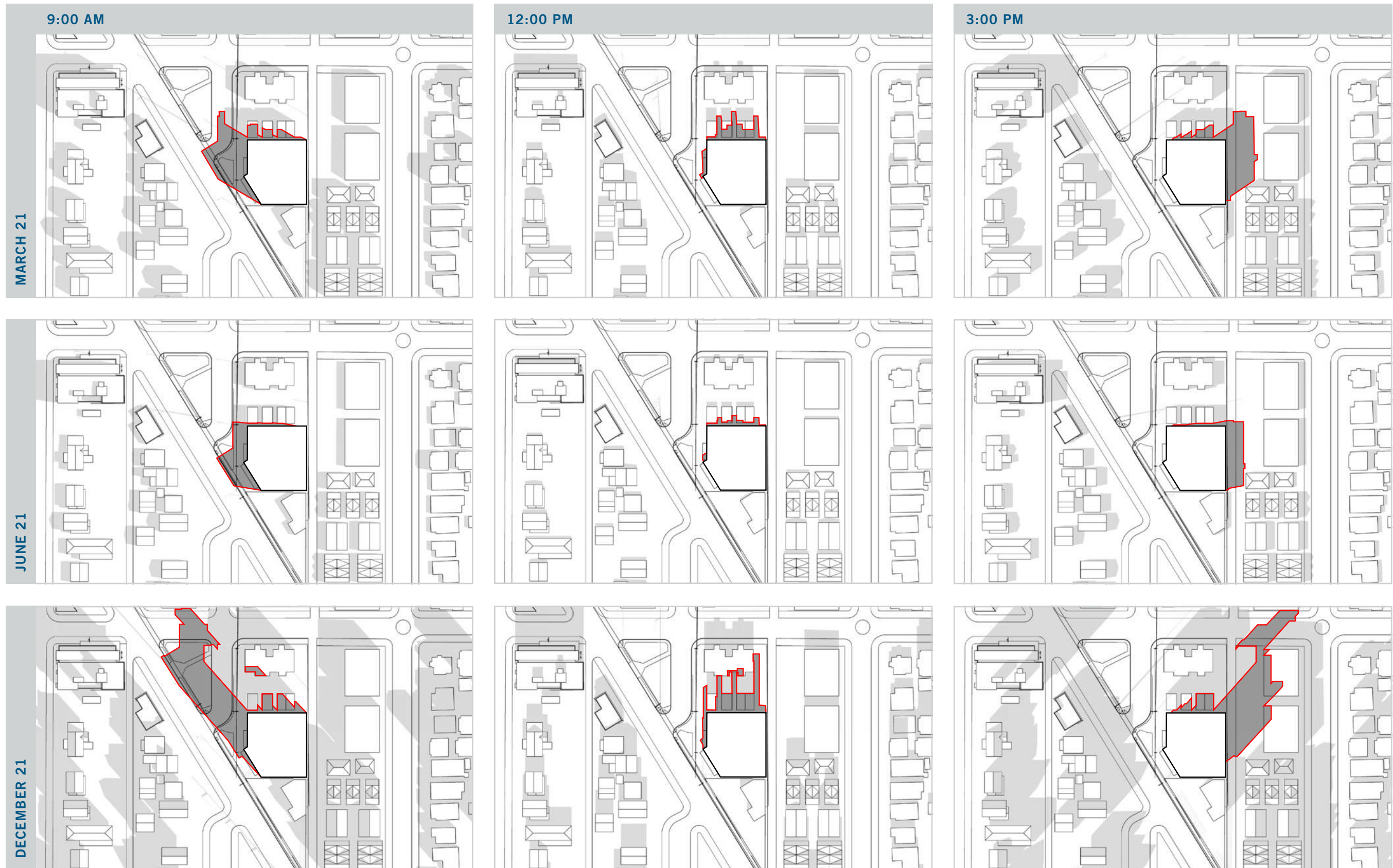

DESIGN PART I - INTERSECTING BOXES

The building's mass can be thought as two intersecting volumes: the larger one sits toward the alley and the smaller one intersects it at a right angle to create a "T" scheme. This helps to create more articulation of the mass toward 18th Ave SW and an open corner at both the northwest and southeast corners of the site. Variations in roofline reinforce the intersecting masses while creating a simple massing.

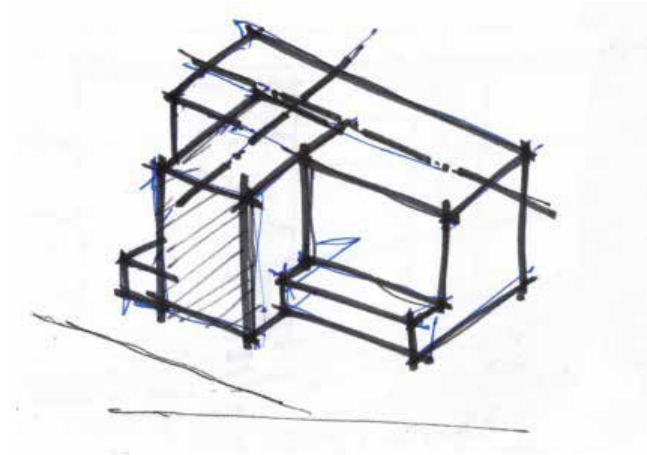

DESIGN PROCESS

STEP 1: BUILD TO ZONING ENVELOPE

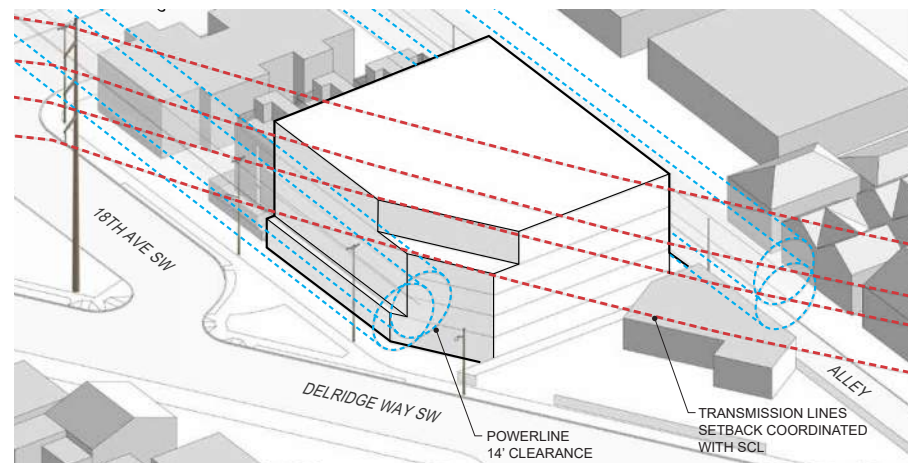

STEP 4: CREATE RECESSES TO RELATE TO TOWNHOME SCALE

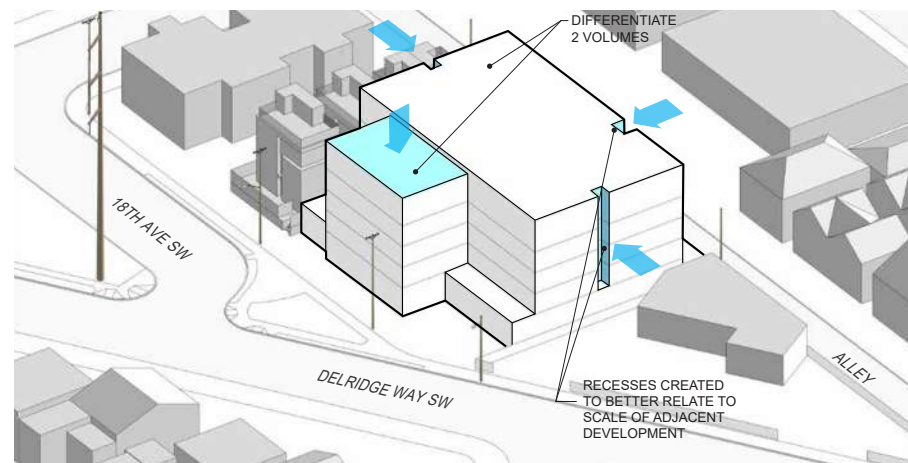

STEP 2: CREATE GENERAL MASSING RELIEF

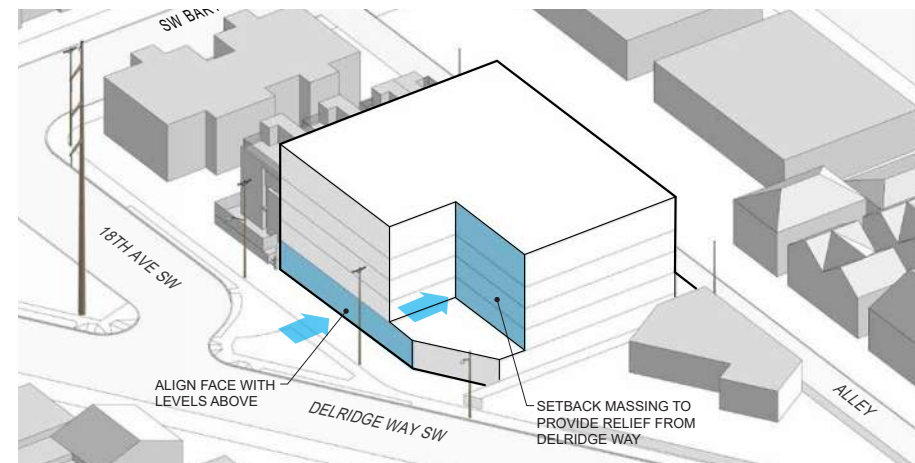

STEP 5: FURTHER ARTICULATION

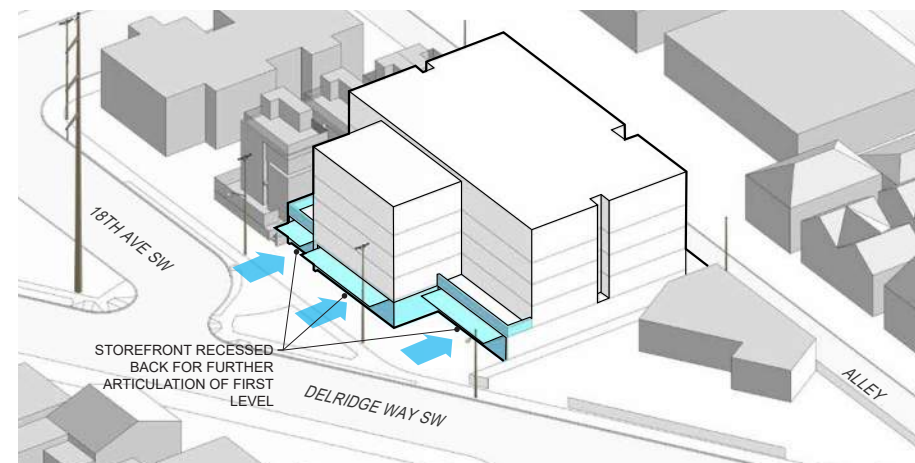

STEP 3: FURTHER MASSING REFINEMENT

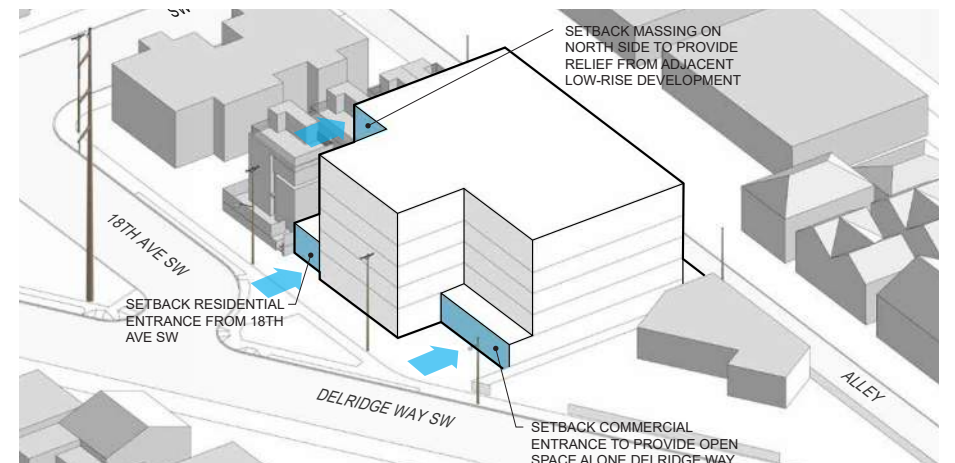

APPENDIX 2 | EDG 1 OPTION 2

DESIGN INSPIRATION



① DC2.A: MASSING

Intersecting masses add visual interest to the facade without over-complicating its geometries.



② CS2.D: HEIGHT, BULK, AND SCALE

Contrasting materials between masses add visual interest and breaks down mass while not overcomplicating geometry.



③ PL1.C: OUTDOOR USES AND ACTIVITIES

Glazing, weather protection, and outdoor elements helps transform this sidewalk into an active pedestrian space.

FINAL CONCEPT MASSING

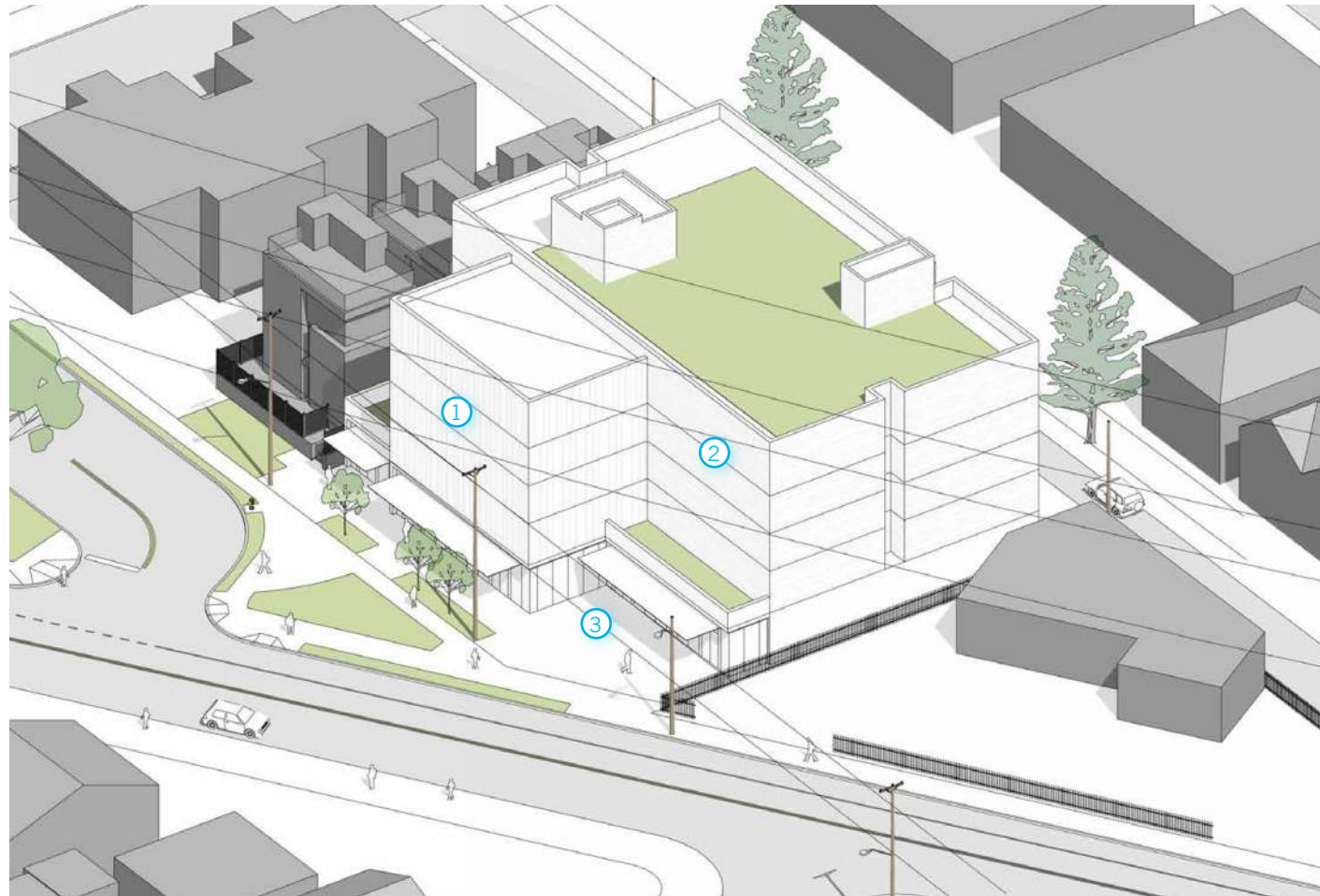

AXONOMETRIC VIGNETTE FROM SOUTHWEST

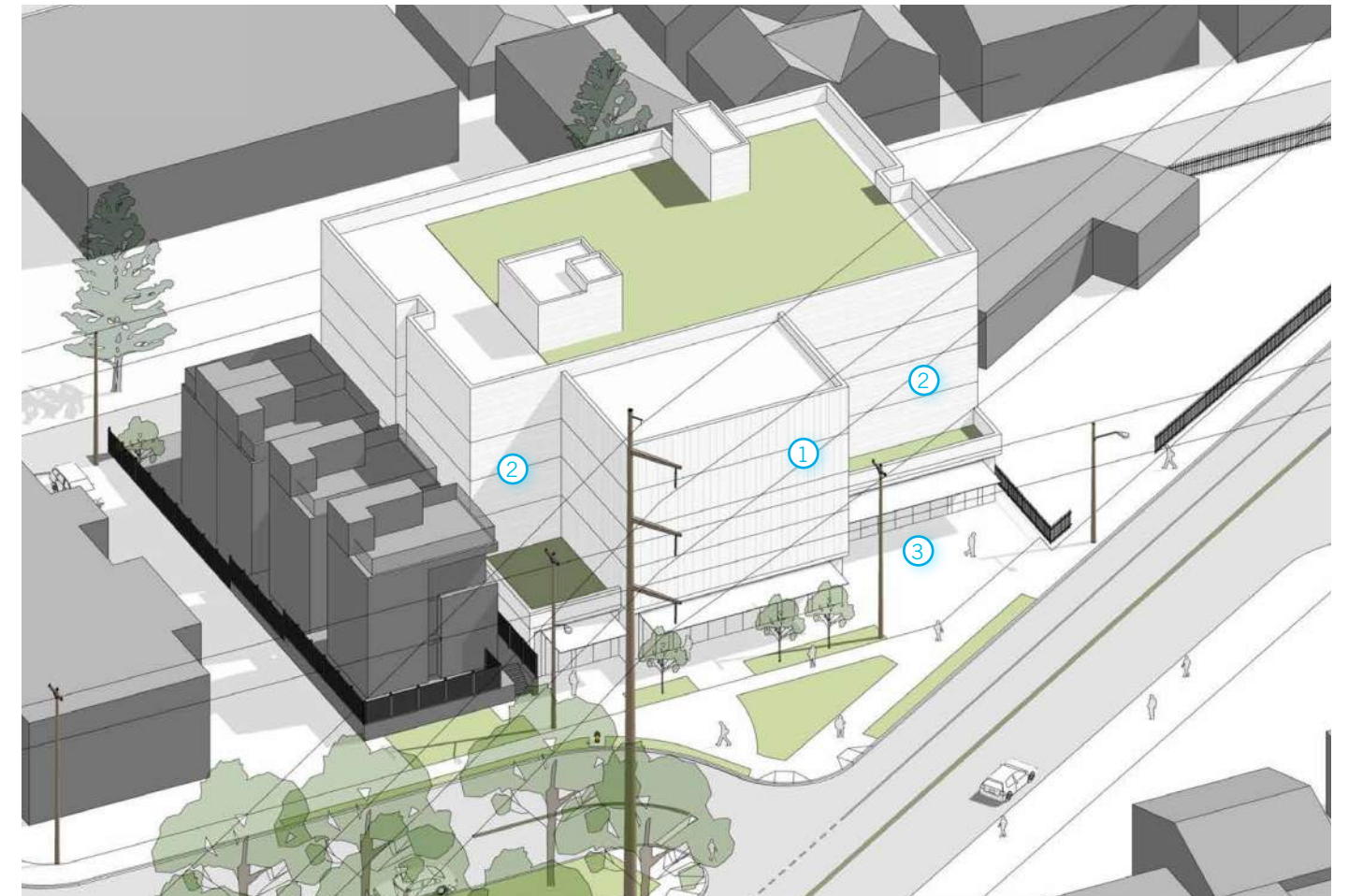

AXONOMETRIC VIGNETTE FROM NORTHWEST

APPENDIX 2 | EDG 1 OPTION 2

DESIGN ANALYSIS



VIEW FROM DELRIDGE WAY SW

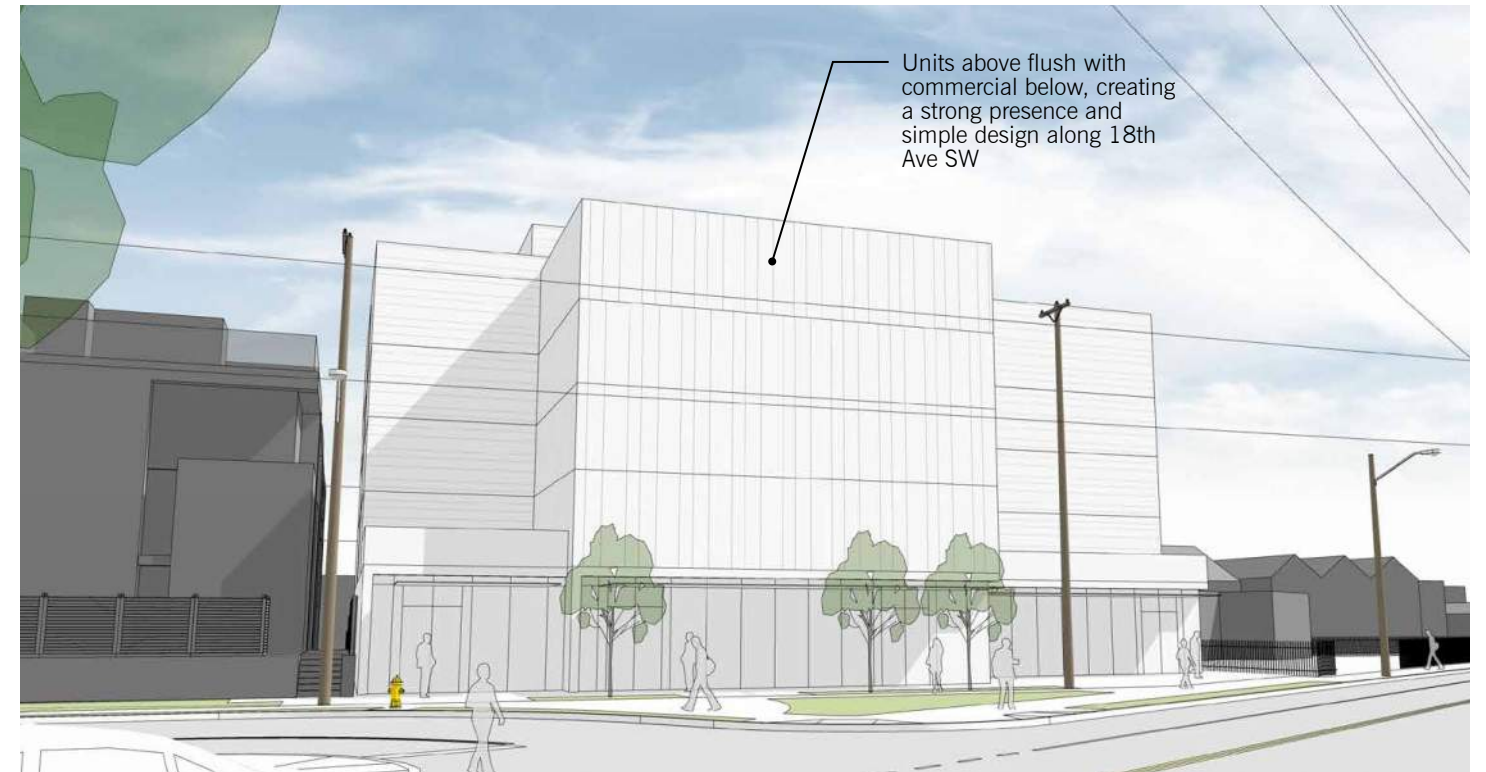

VIEW FROM DELRIDGE WAY SW AND 18TH AVE SW

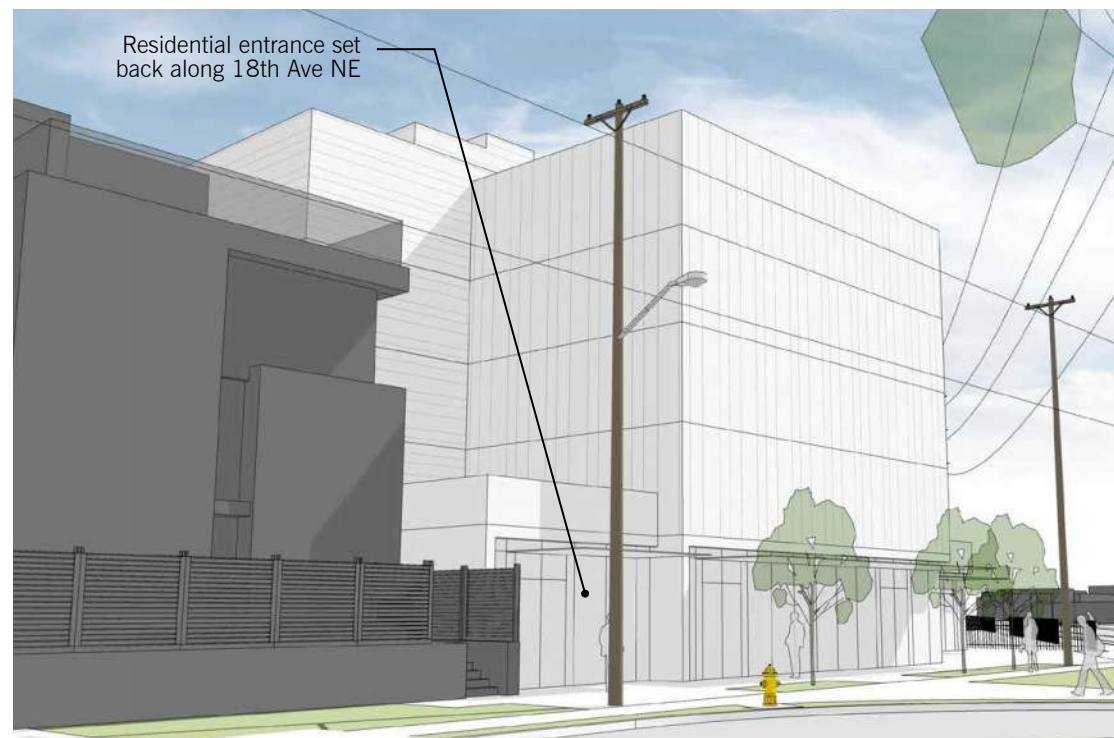

VIEW FROM 18TH AVE SW



VIEW FROM DELRIDGE WAY SW LOOKING NORTH

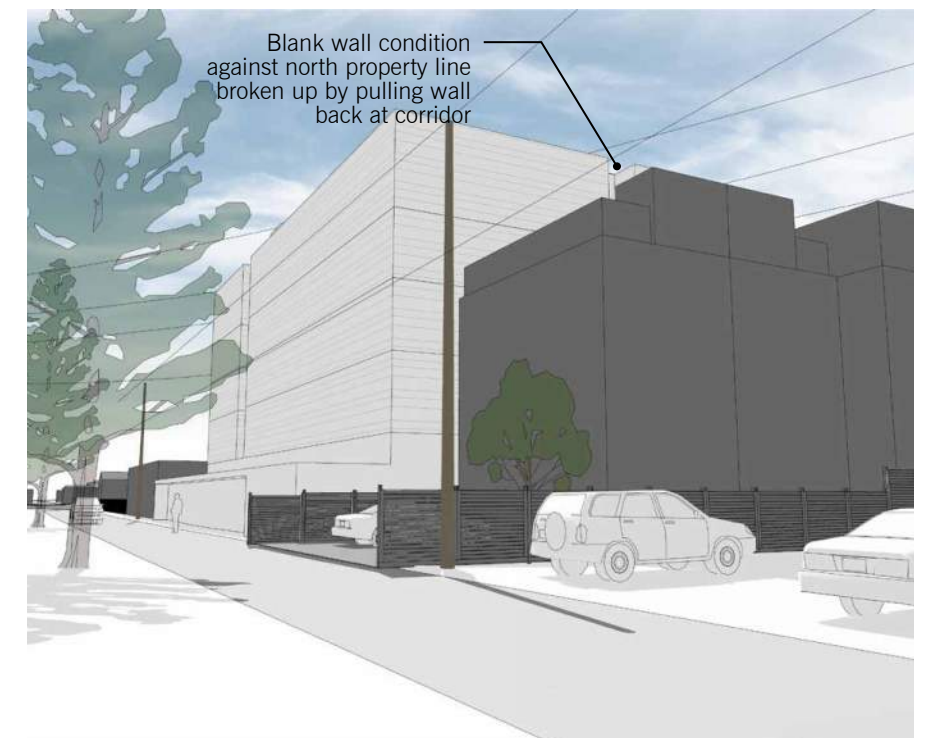

VIEW FROM ALLEY LOOKING SOUTH

APPENDIX 2 | EDG 1 OPTION 2



AERIAL VIEW FROM SOUTHWEST

APPENDIX 2 | EDG 1 OPTION 2



Canyon-like effect
between north
facade and adjacent
development

AERIAL VIEW FROM NORTHWEST

APPENDIX 2 | EDG 1 OPTION 2

KEY

- Commercial
- Residential
- Utility/BOH
- Circulation
- Planting Strip
- Residential Amenity
- Parking/Garage
- Balcony

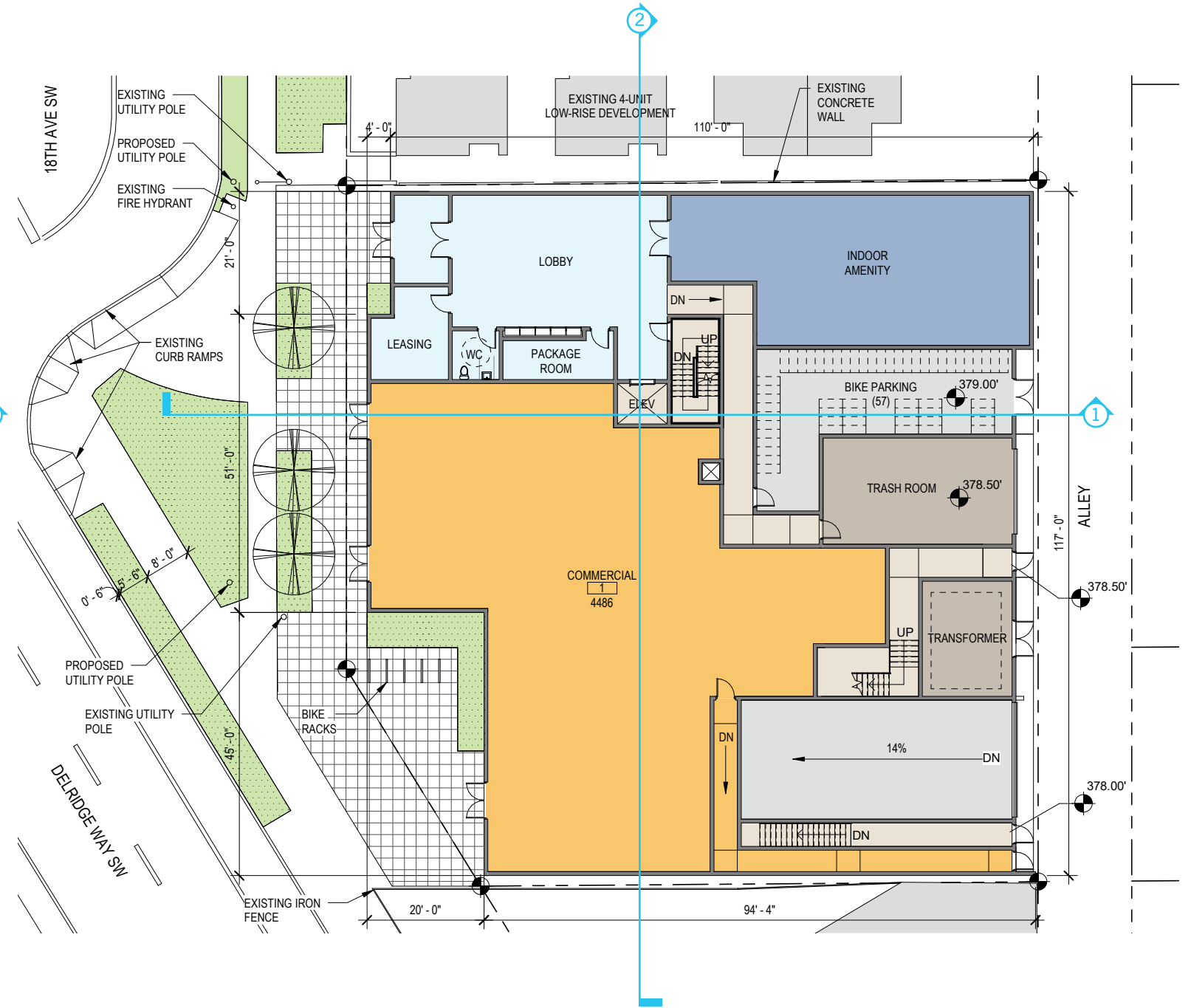
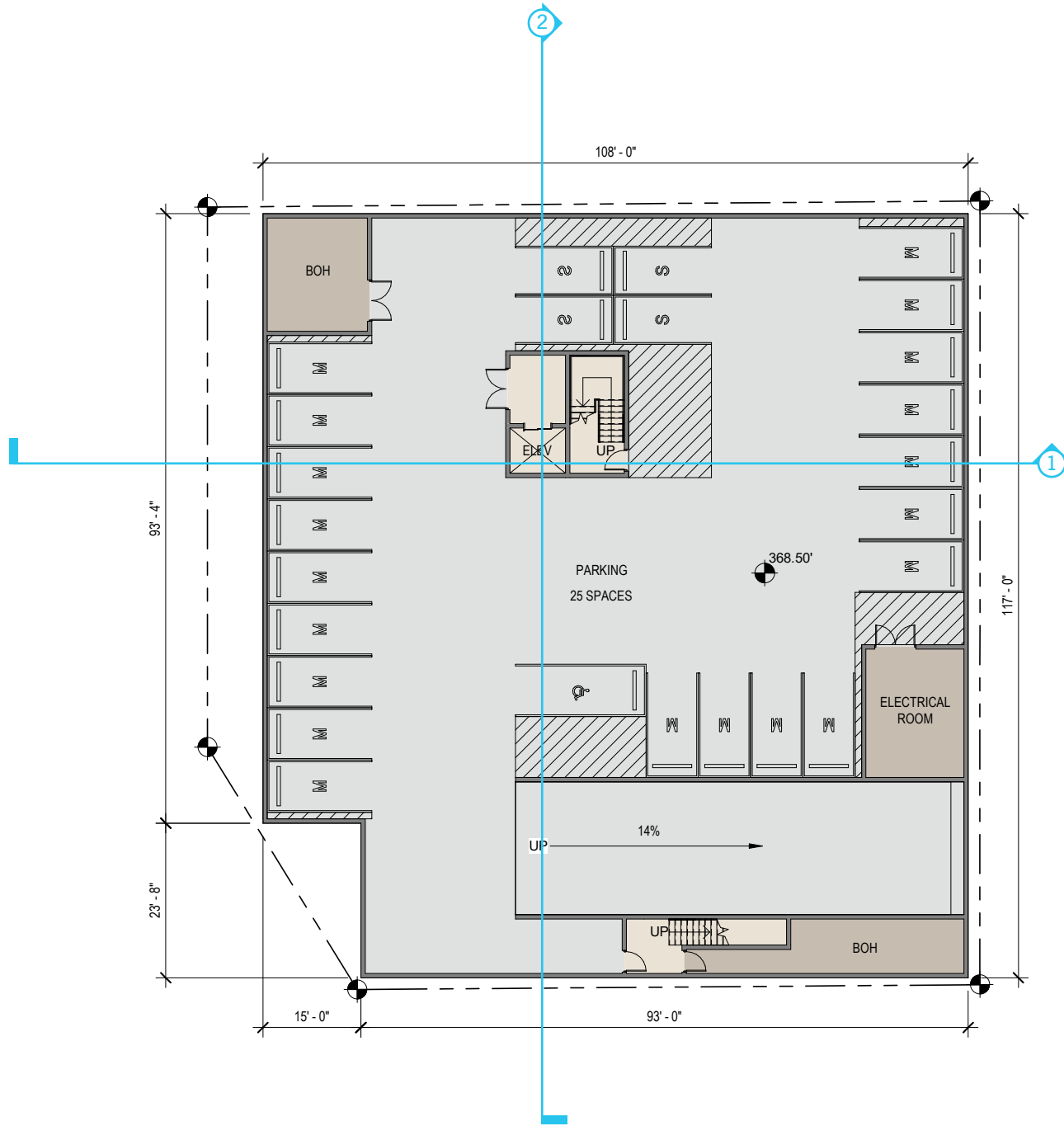

APPENDIX 2 | EDG 1 OPTION 2

KEY

- Commercial
- Planting Strip
- Residential
- Residential Amenity
- Utility/BOH
- Parking/Garage
- Circulation
- Balcony

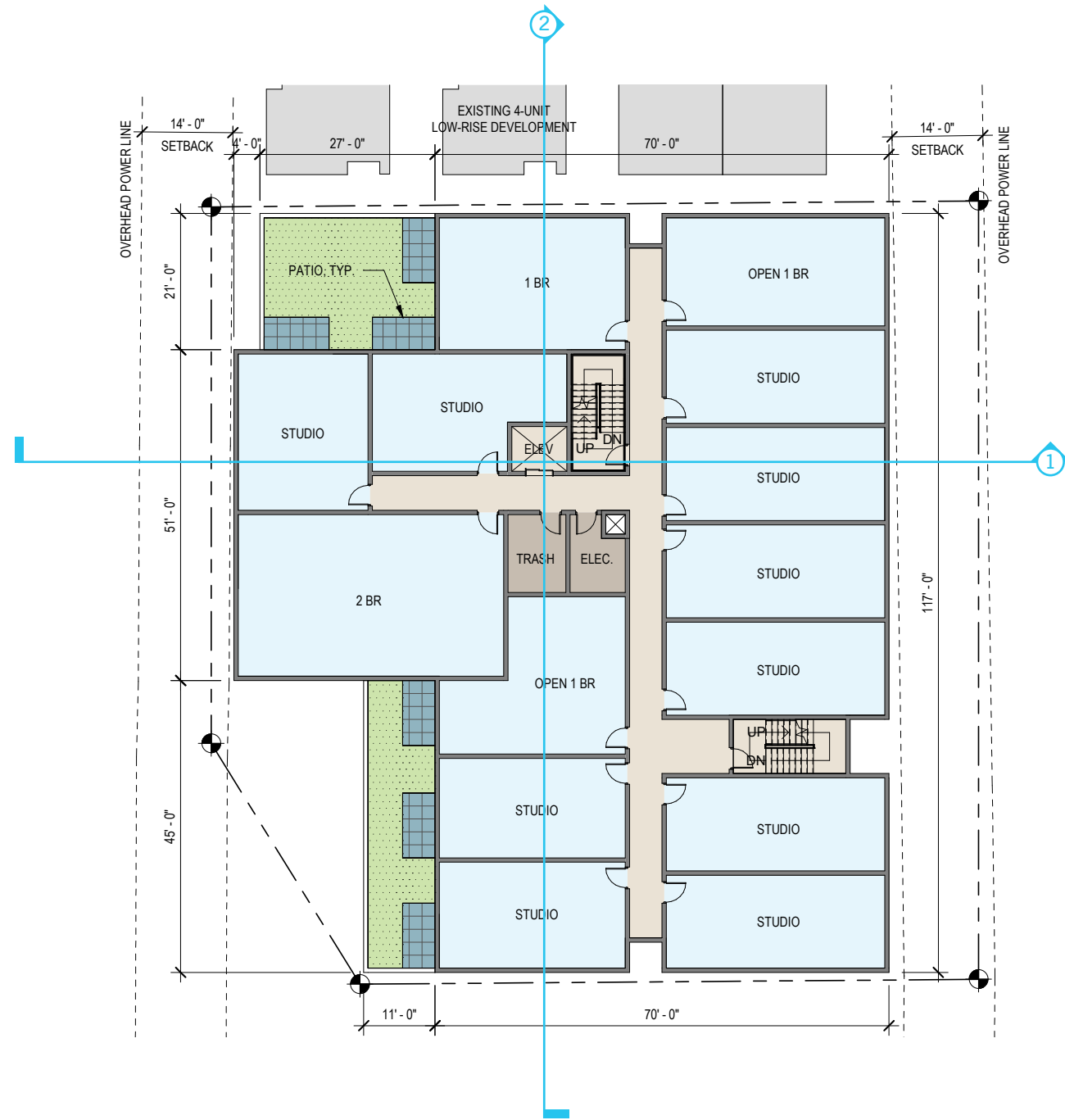

LEVEL 2

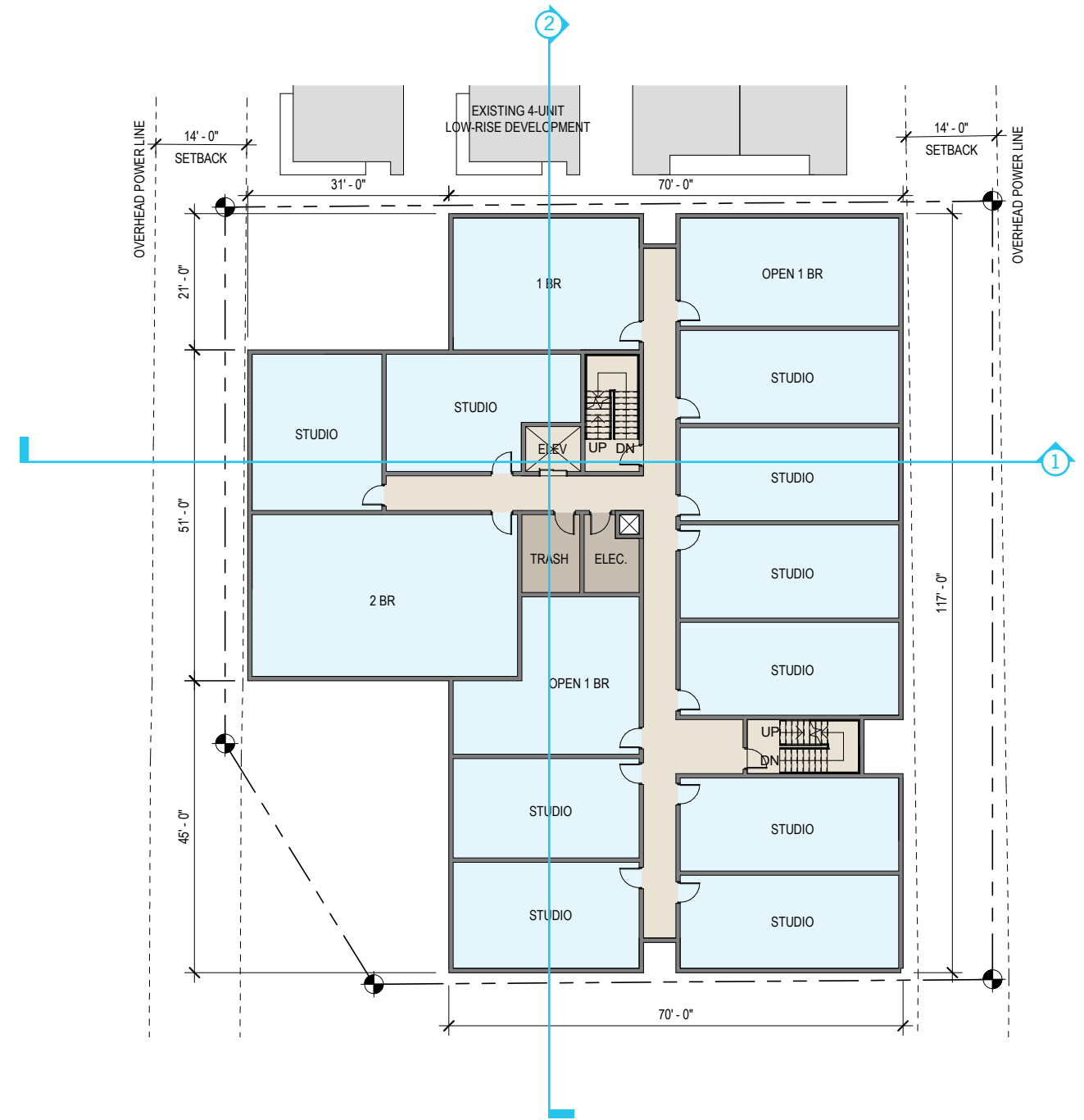

LEVEL 3-4



APPENDIX 2 | EDG 1 OPTION 2

KEY

- Commercial
- Planting Strip
- Residential
- Residential Amenity
- Utility/BOH
- Parking/Garage
- Circulation
- Balcony

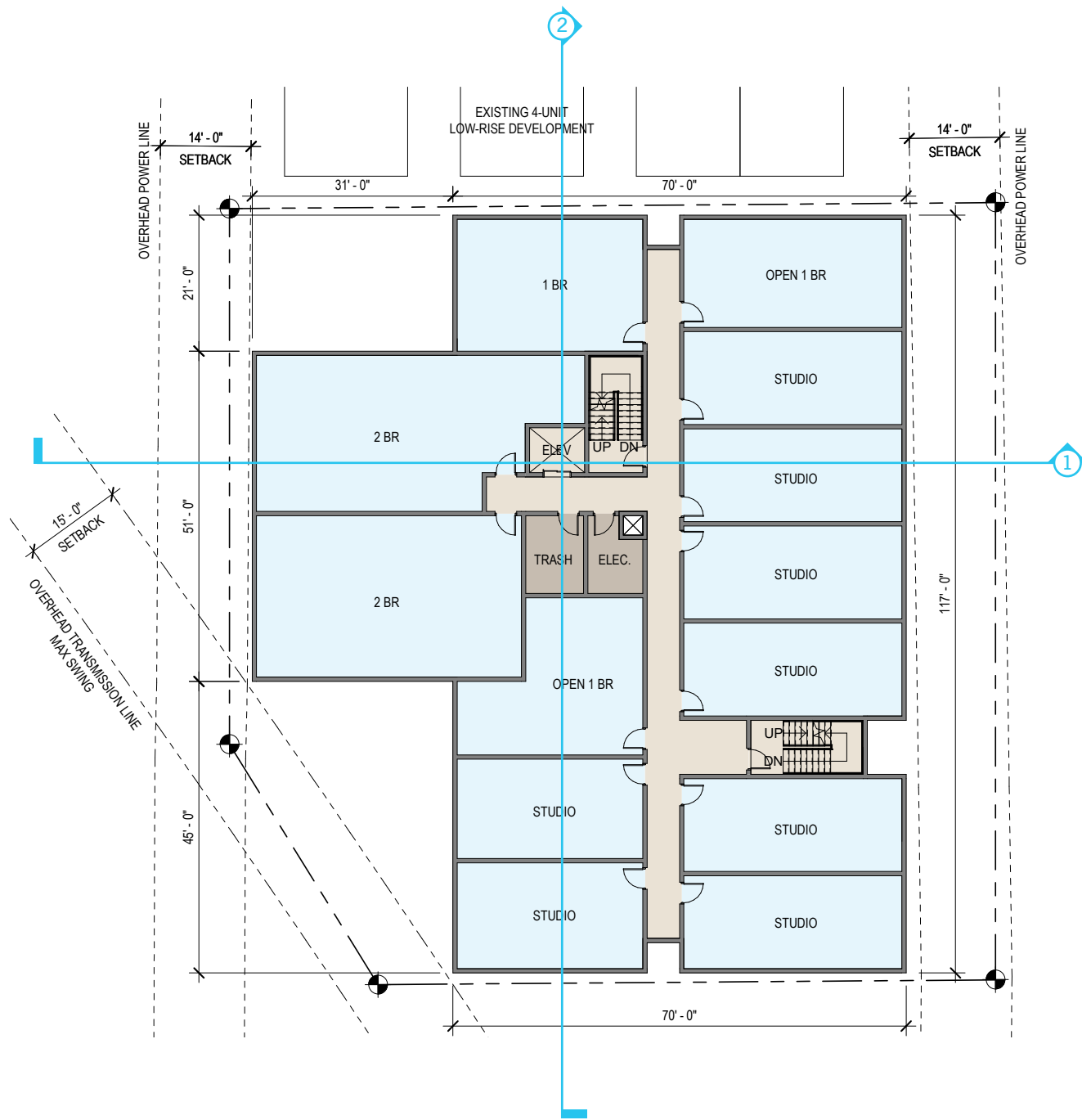

LEVEL 5

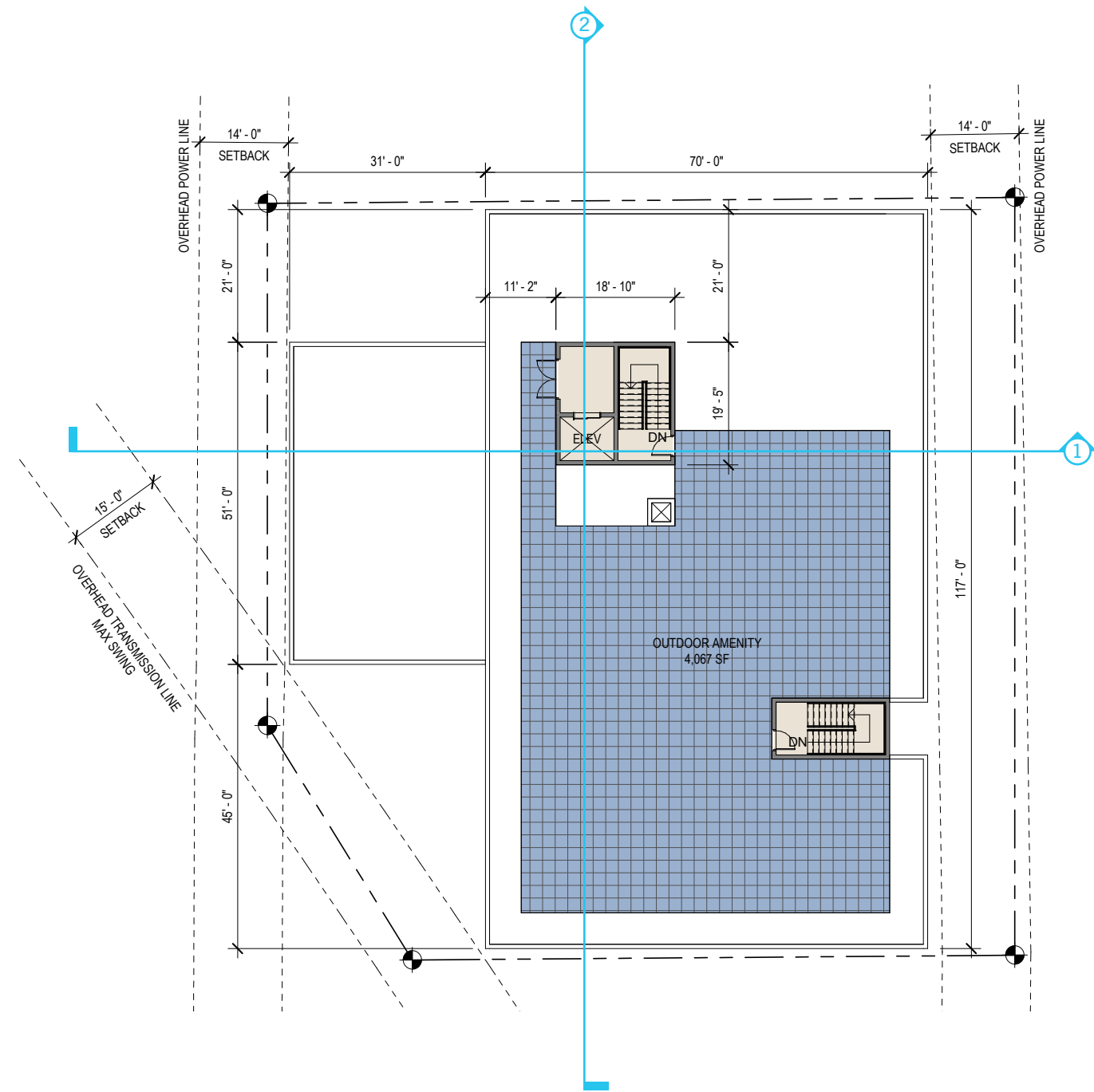

ROOF



APPENDIX 2 | EDG 1 OPTION 2

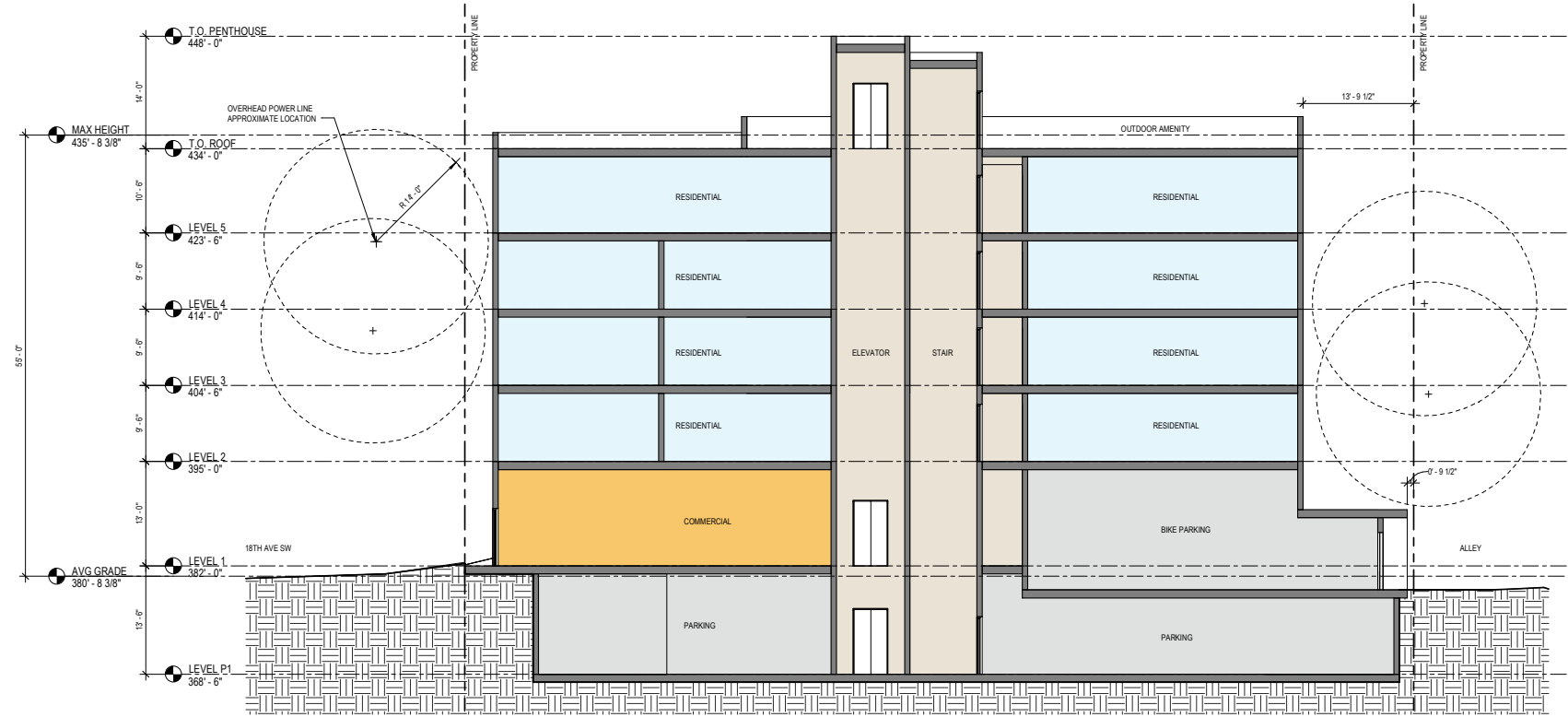

SECTION 1

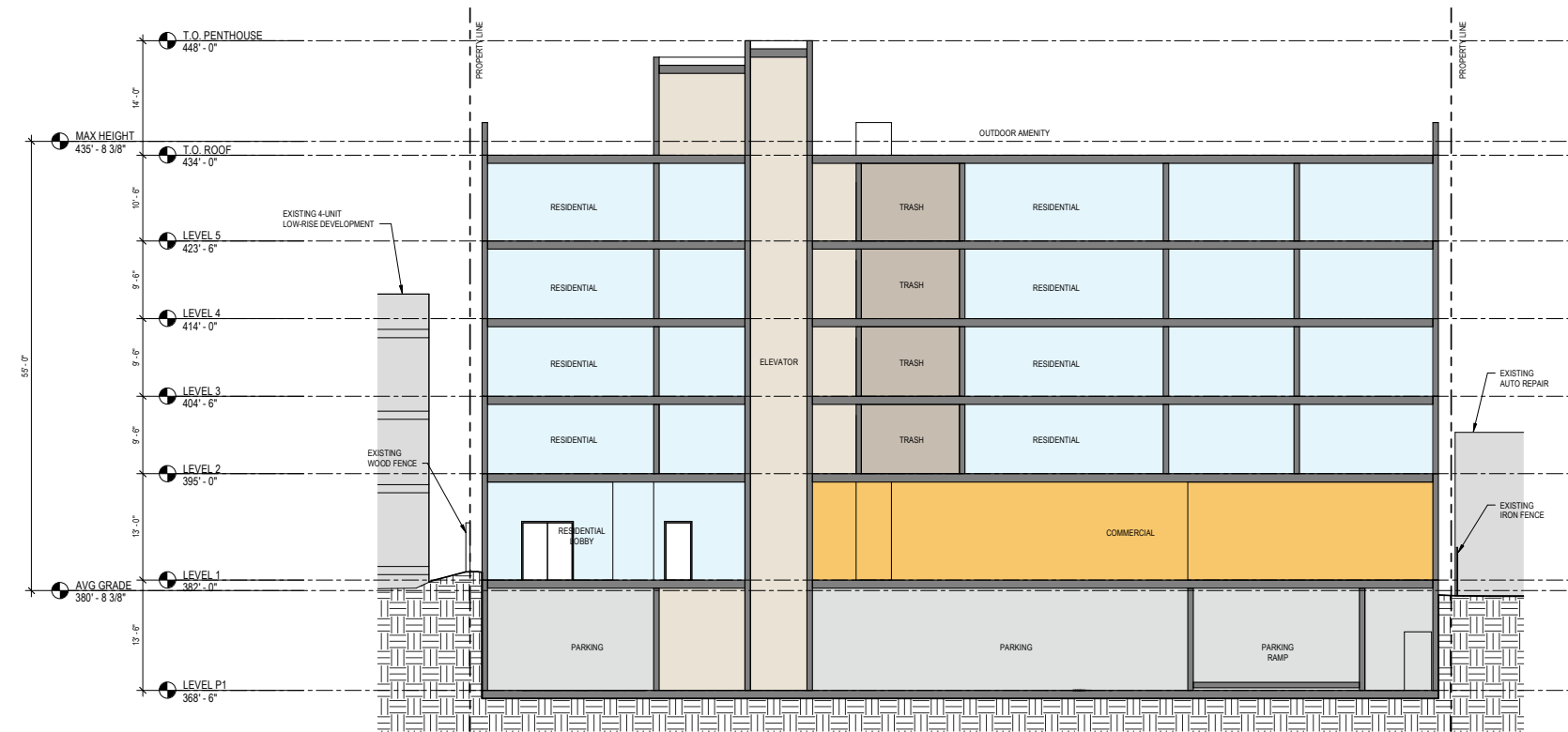

SECTION 2

- KEY**
- Commercial
 - Residential
 - Utility/BOH
 - Circulation
 - Parking

APPENDIX 2 | EDG 1 OPTION 2

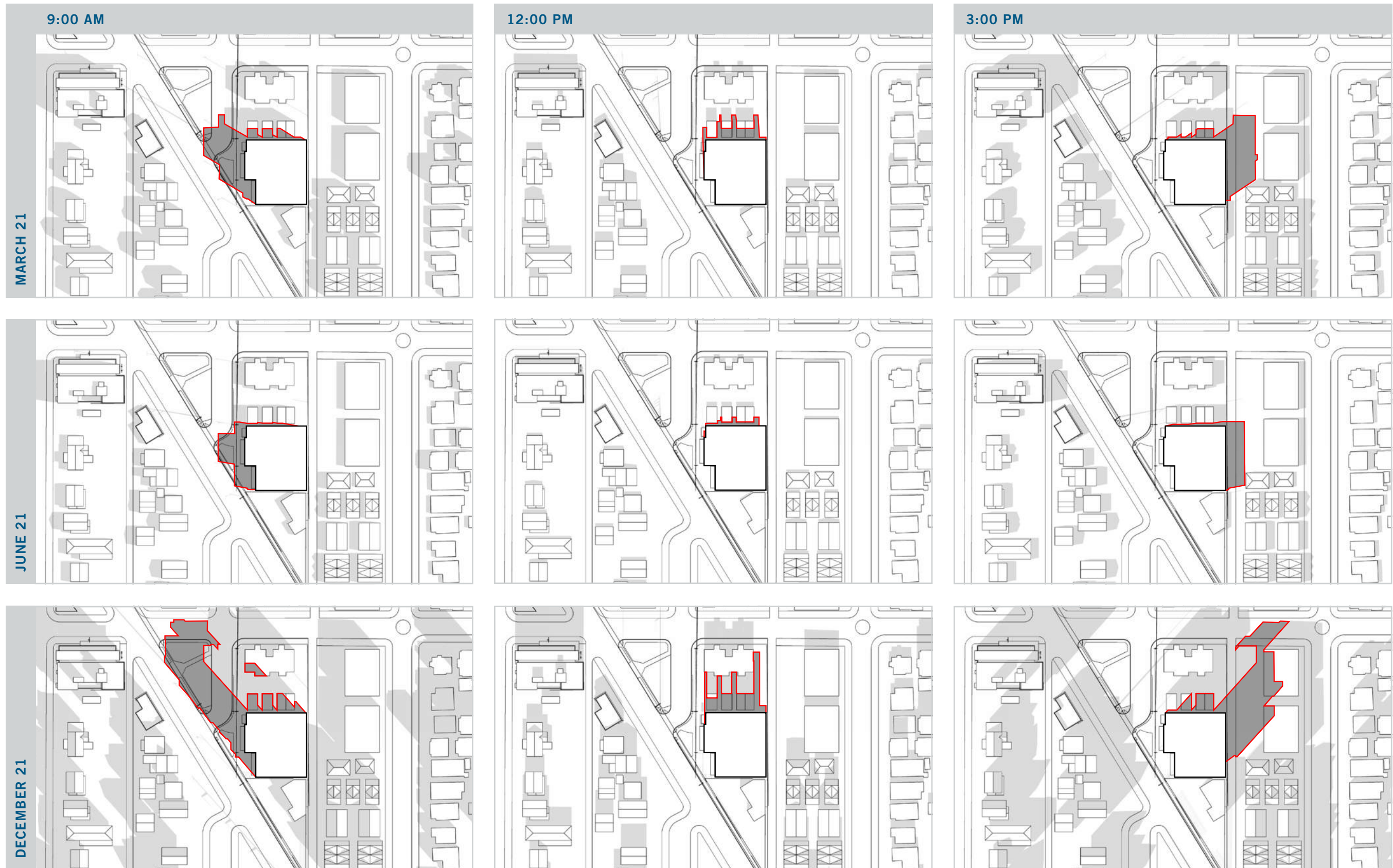

APPENDIX 2 | EDG 1 OPTION 3 (PREFERRED)

DESIGN PART I - SHIFTING FRAMES

The building's mass can be thought as separate smaller volumes relating to the scale of the neighborhood building typologies, but are then contained within frames that slide in relationship to each other. The main massing is subdivided into volumes that relate to the adjacent 3-story townhomes. These are then contained in a frame, and then a frame for the base slides under it. The base contains the retail and retail frontages that recessed separately. This frame at the base is expressed proud of the upper massing to create a distinction of 1-story that relates to the typical 1-story, pedestrian scaled retail in the area. These frames are in a dynamic sliding juxtaposition to add a contemporary expression, and to express a more open southern end to Delridge Way, and a more closed termination towards the more private residential end on 18th Avenue.

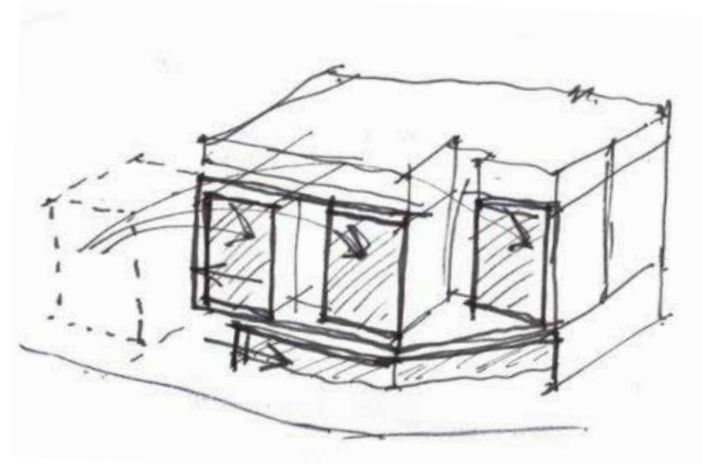

ADJACENT RESIDENTIAL DEVELOPMENT

COPY SCALE



1. CONTEXT SCALE

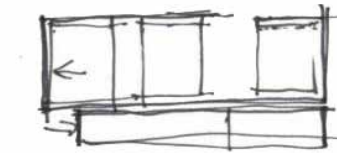

3. CONTAIN & WRAP



2. ADD BASE

SLIDE IN 1-STORY BASE

DESIGN PROCESS

STEP 1: BUILD TO ZONING ENVELOPE

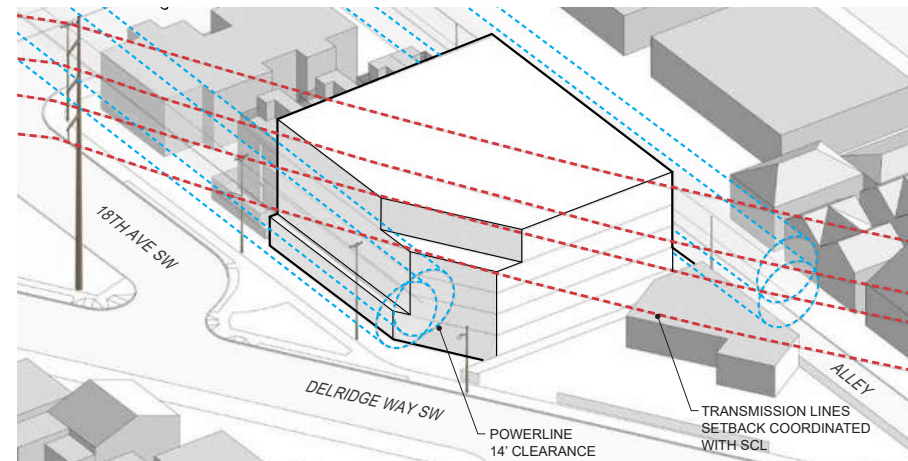

STEP 4: CREATE RECESSES TO RELATE TO TOWNHOME SCALE

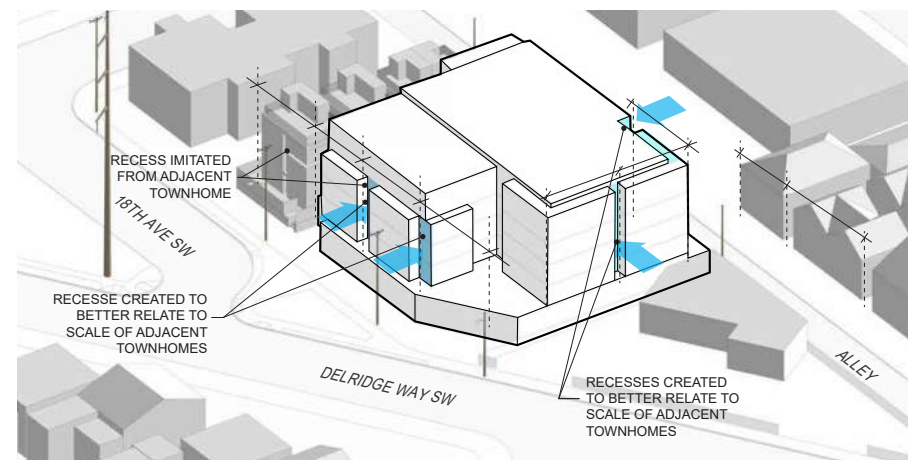

STEP 2: CREATE GENERAL MASSING RELIEF

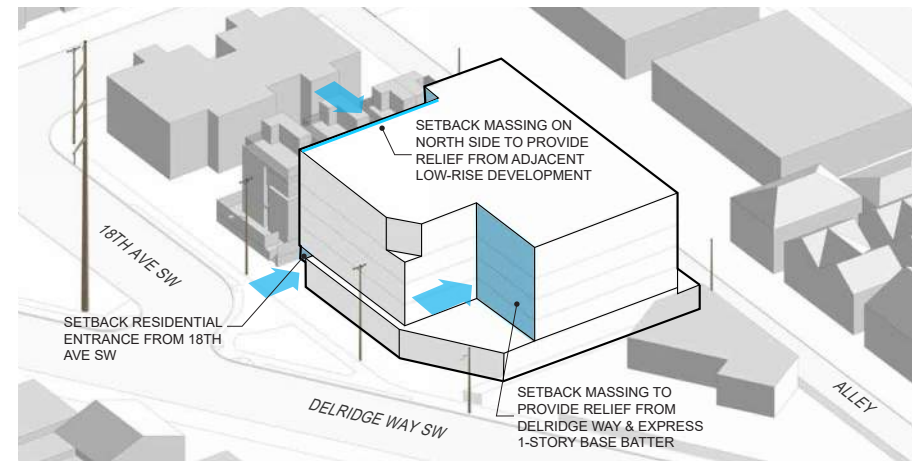

STEP 5: FURTHER ARTICULATION

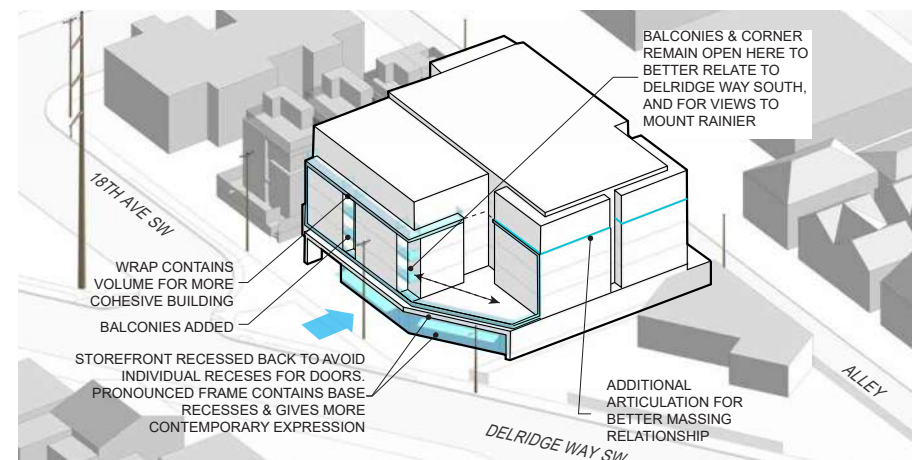

STEP 3: FURTHER MASSING REFINEMENT

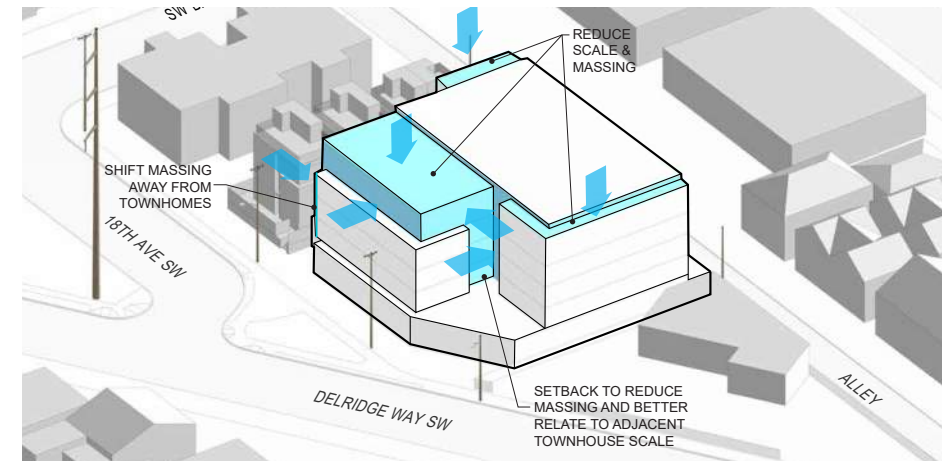

APPENDIX 2 | EDG 1 OPTION 3 (PREFERRED)

DESIGN INSPIRATION



①



②



③



③

DC2.A: MASSING; & CS2.D: HEIGH, BULK, & SCALE

The massing is broken down to relate to the 1-story retail and 3-story townhomes in the area. The base is expressed proud of the upper levels. The upper levels are broken to the scale of the townhomes. Frames help to contain the smaller volumes to make a more cohesive whole.

FINAL CONCEPT MASSING

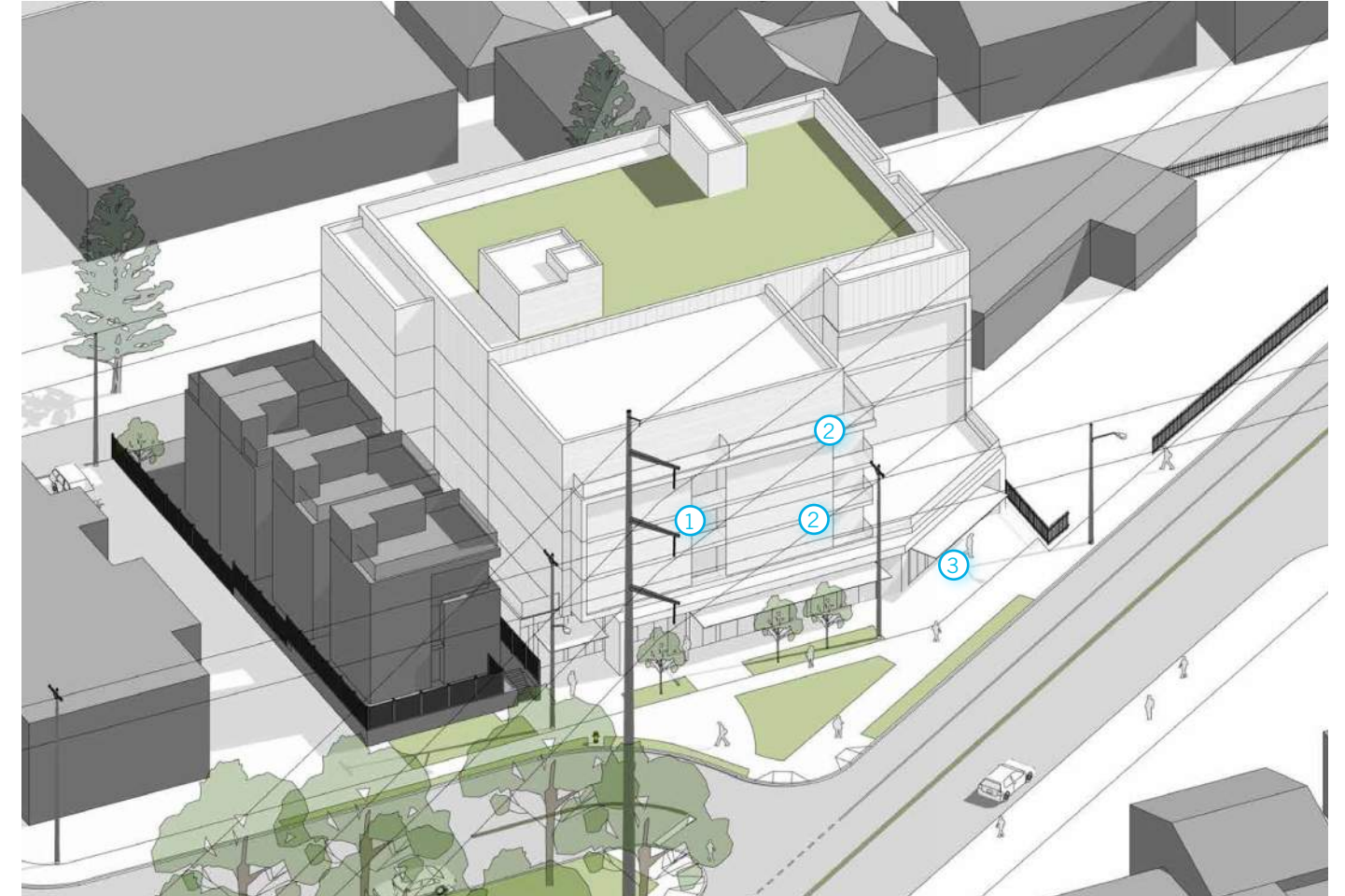
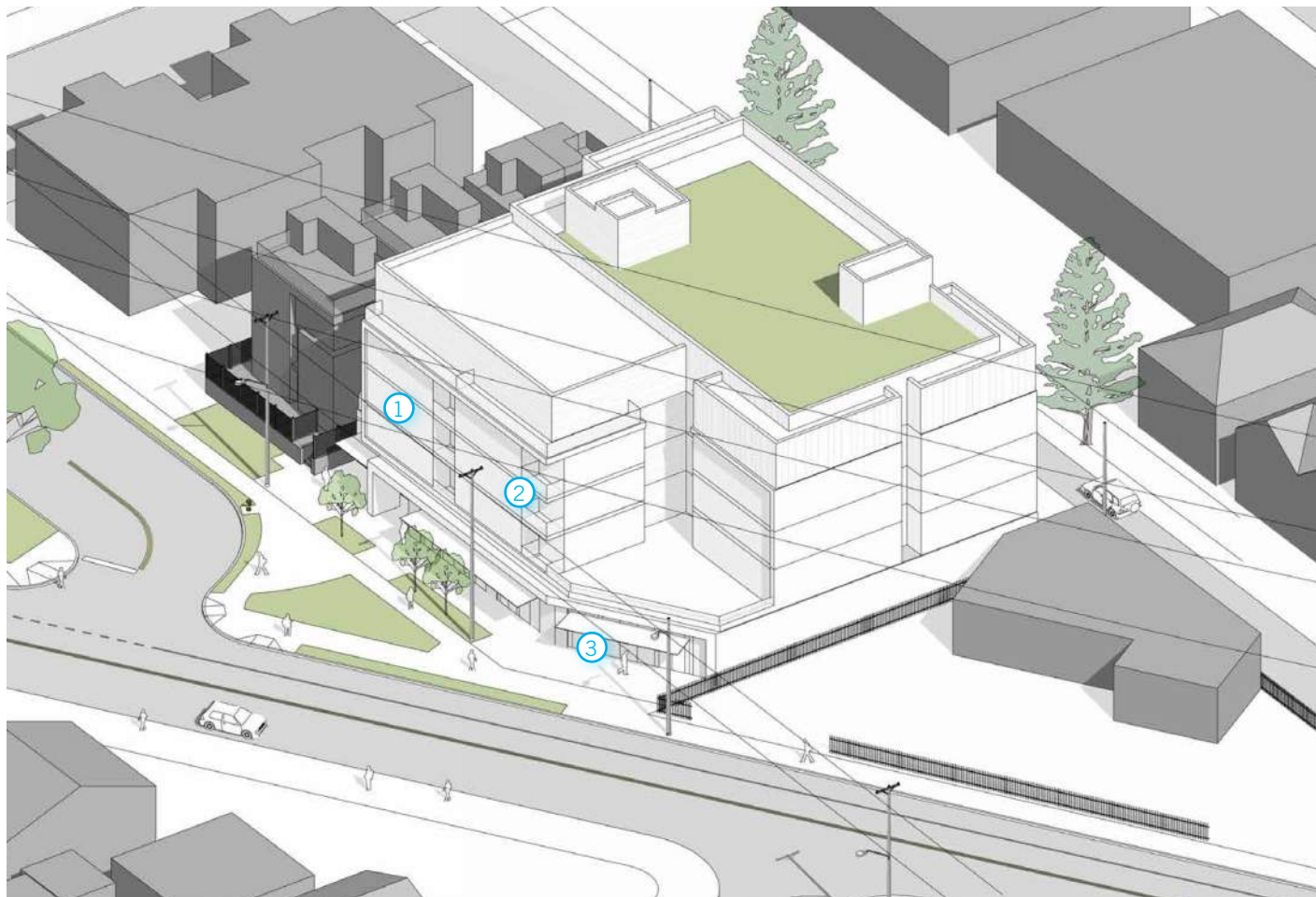

AXONOMETRIC VIGNETTE FROM SOUTHWEST

AXONOMETRIC VIGNETTE FROM NORTHWEST

APPENDIX 2 | EDG 1 OPTION 3 (PREFERRED)

DESIGN ANALYSIS

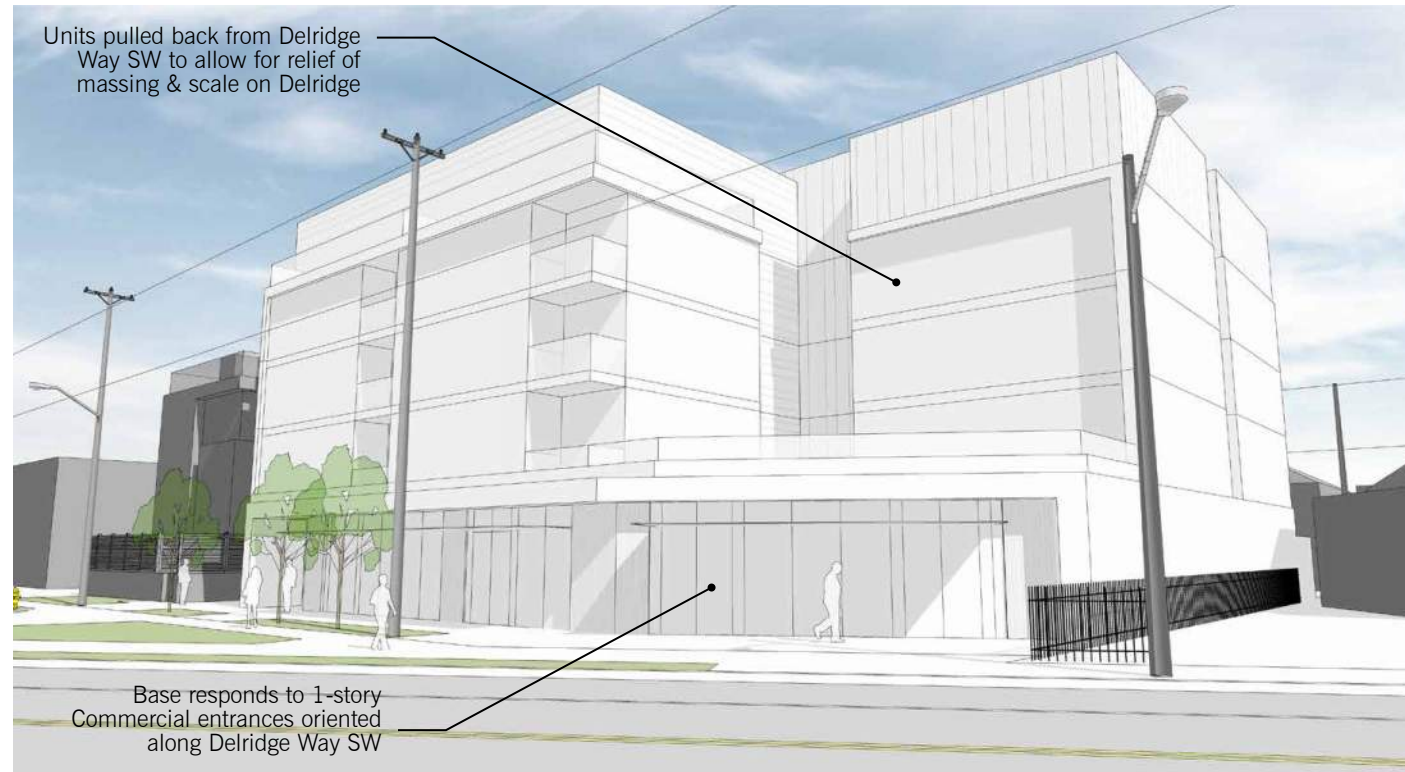

VIEW FROM DELRIDGE WAY SW

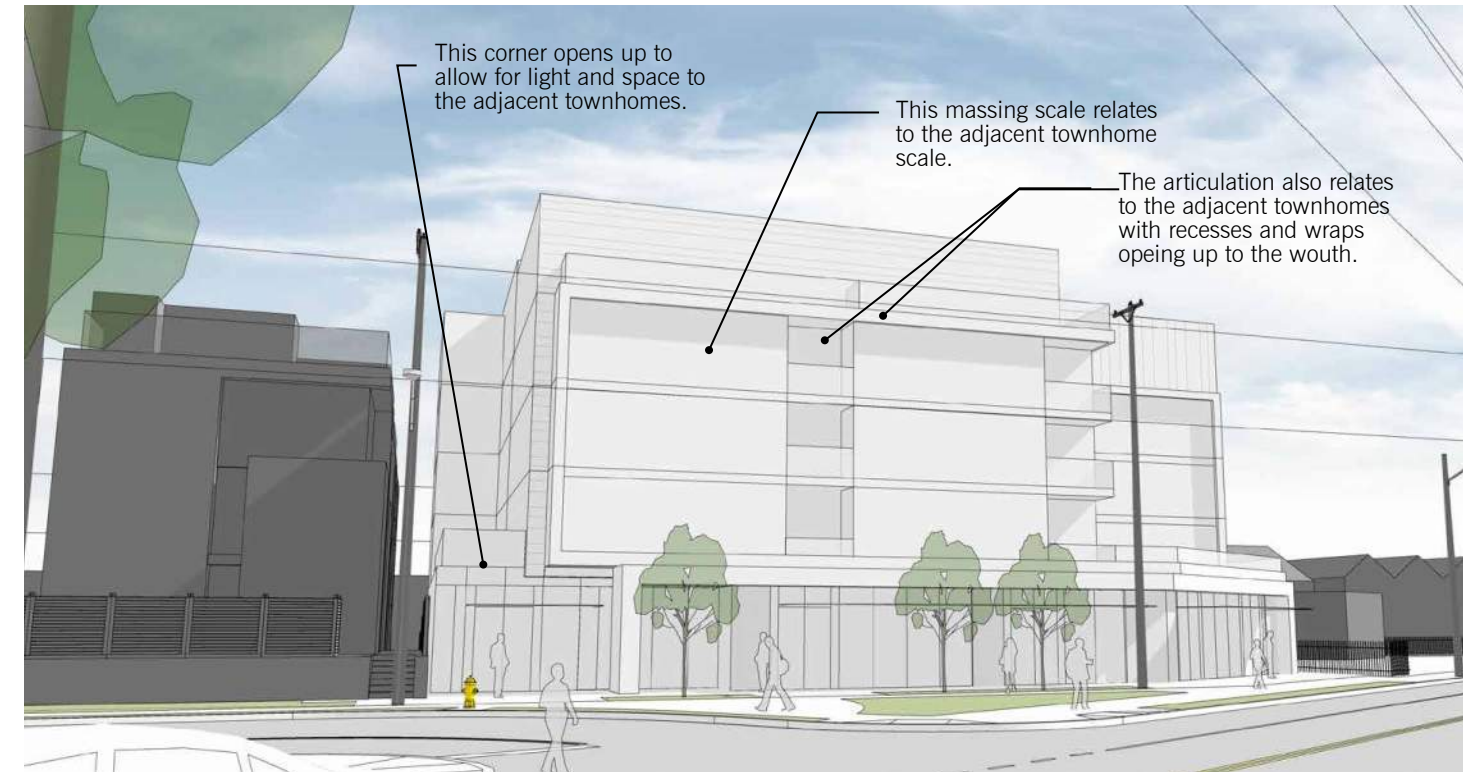

VIEW FROM DELRIDGE WAY SW AND 18TH AVE SW

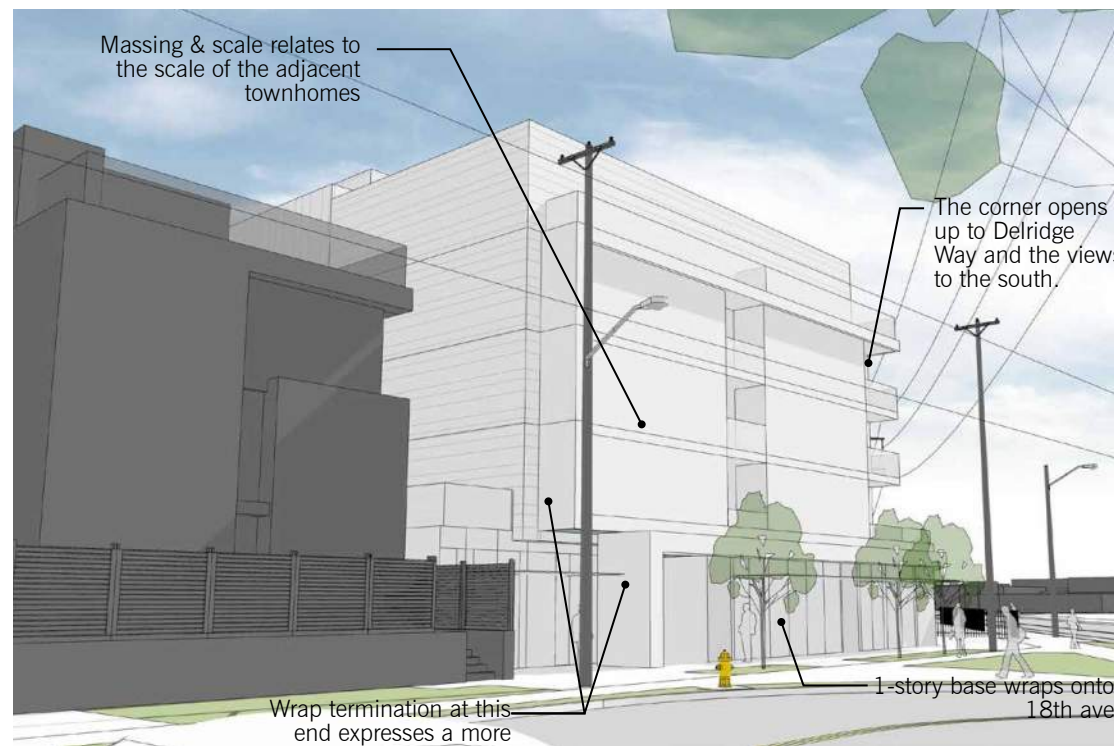

VIEW FROM 18TH AVE SW

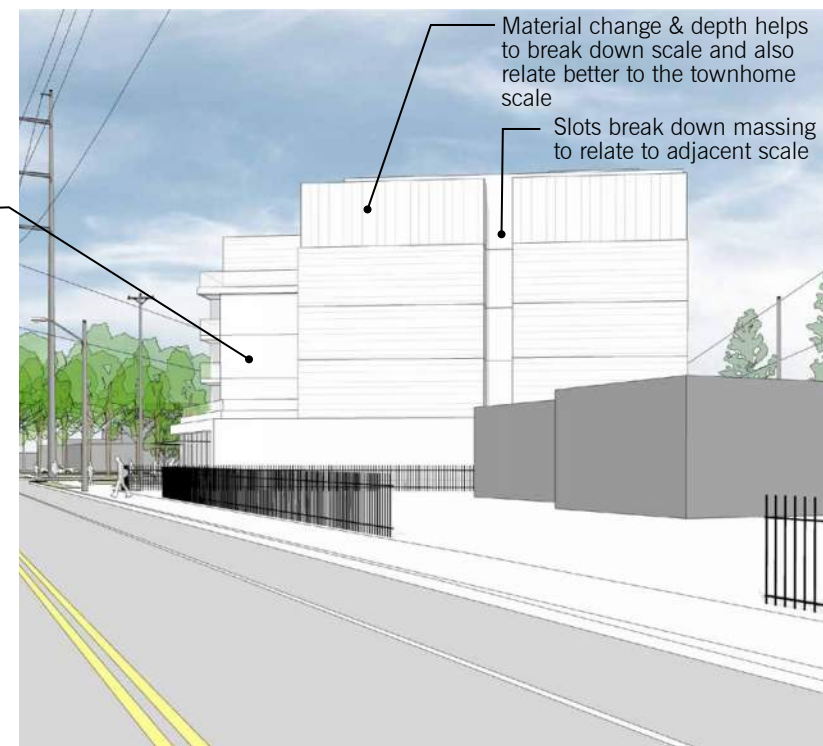

VIEW FROM DELRIDGE WAY SW LOOKING NORTH

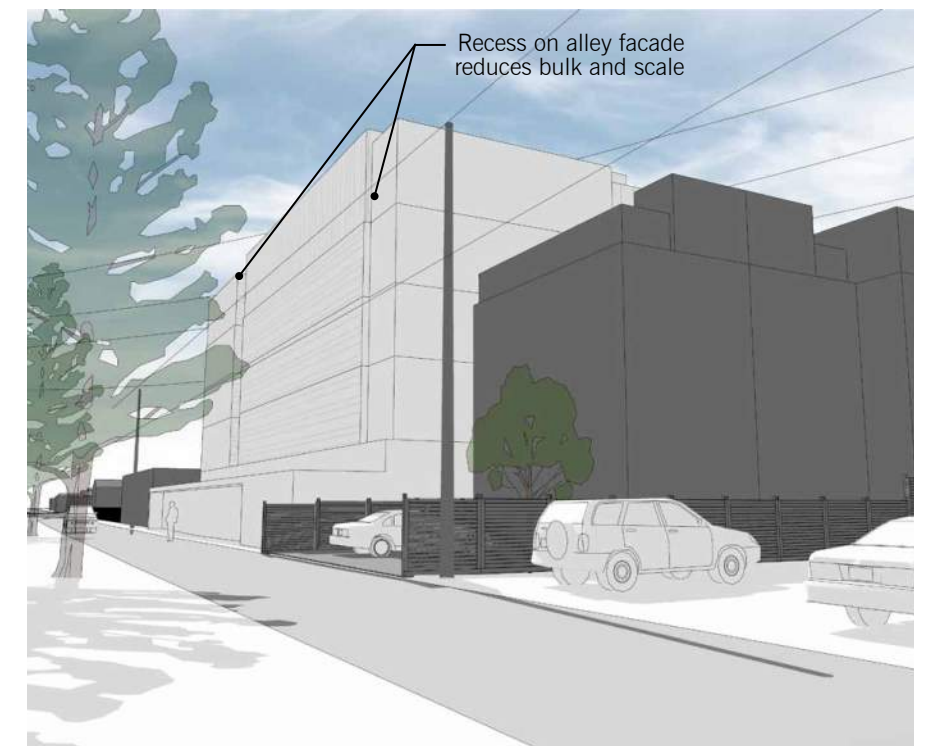

VIEW FROM ALLEY LOOKING SOUTH

APPENDIX 2 | EDG 1 OPTION 3 (PREFERRED)



AERIAL VIEW FROM SOUTHWEST

APPENDIX 2 | EDG 1 OPTION 3 (PREFERRED)



AERIAL VIEW FROM NORTHWEST

APPENDIX 2 | EDG 1 OPTION 3 (PREFERRED)

KEY

- Commercial
- Planting Strip
- Residential
- Residential Amenity
- Utility/BOH
- Parking/Garage
- Circulation
- Balcony

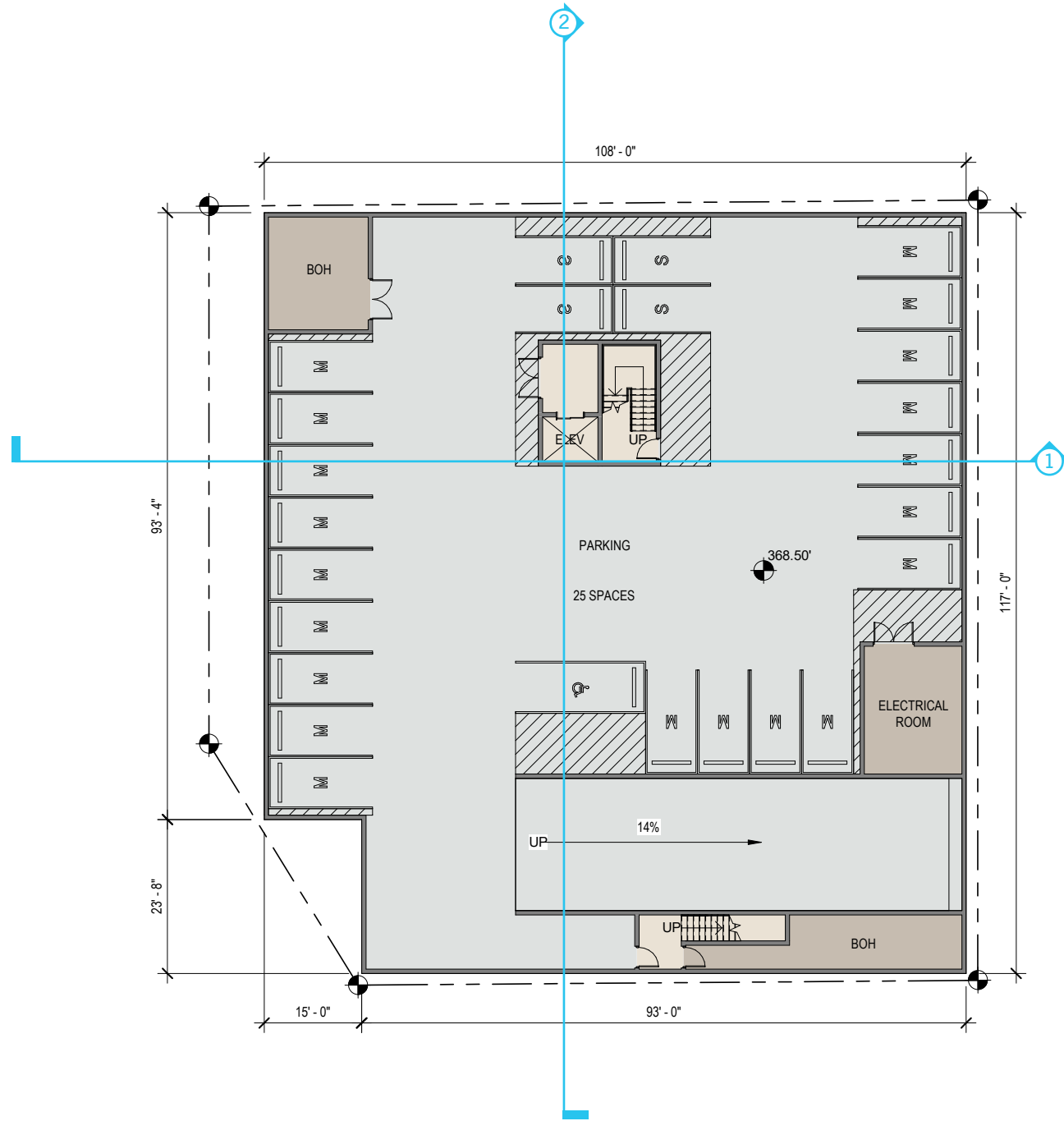

LEVEL P1

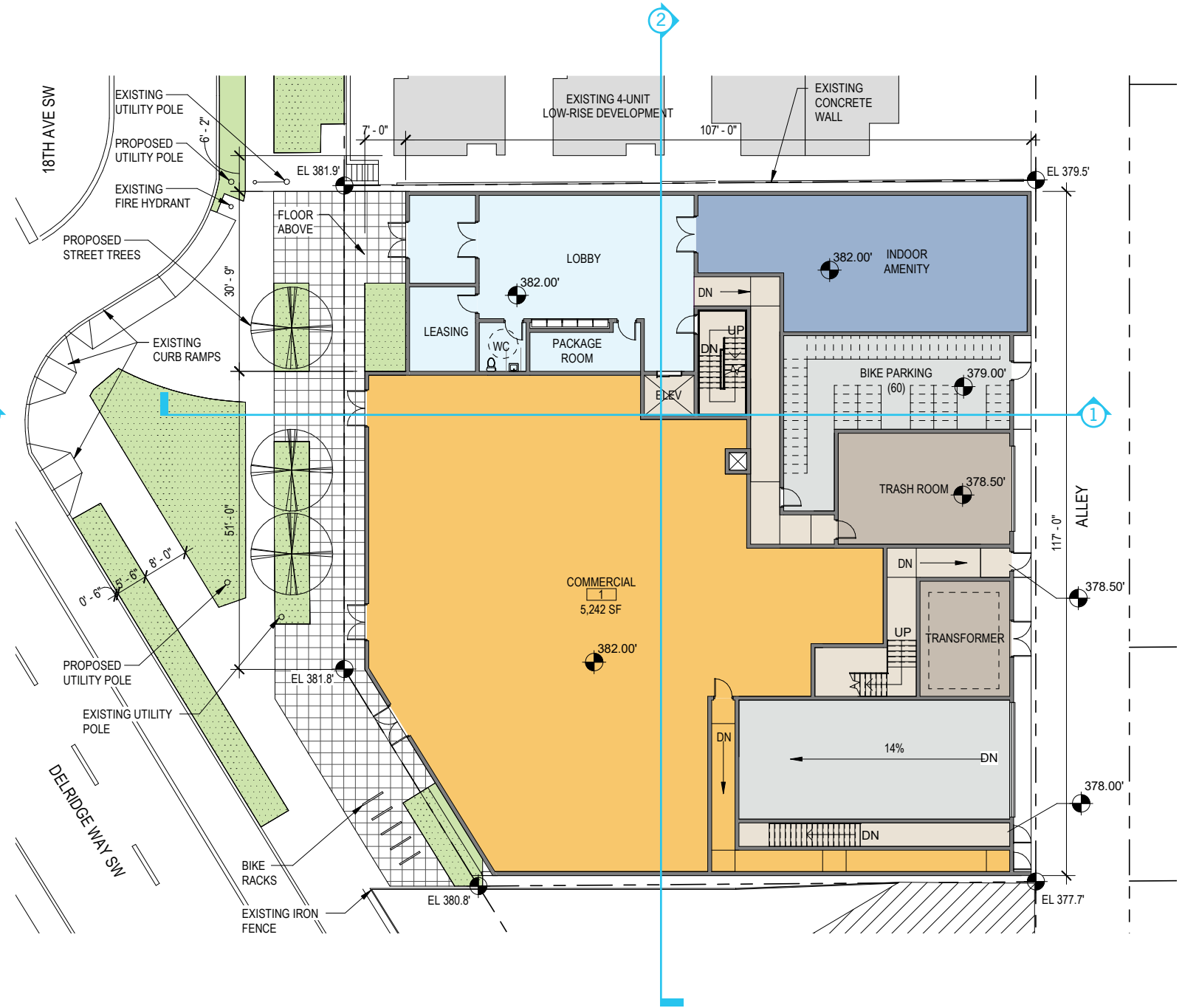

LEVEL 1



APPENDIX 2 | EDG 1 OPTION 3 (PREFERRED)

KEY

- Commercial
- Planting Strip
- Residential
- Residential Amenity
- Utility/BOH
- Parking/Garage
- Circulation
- Balcony



LEVEL 2

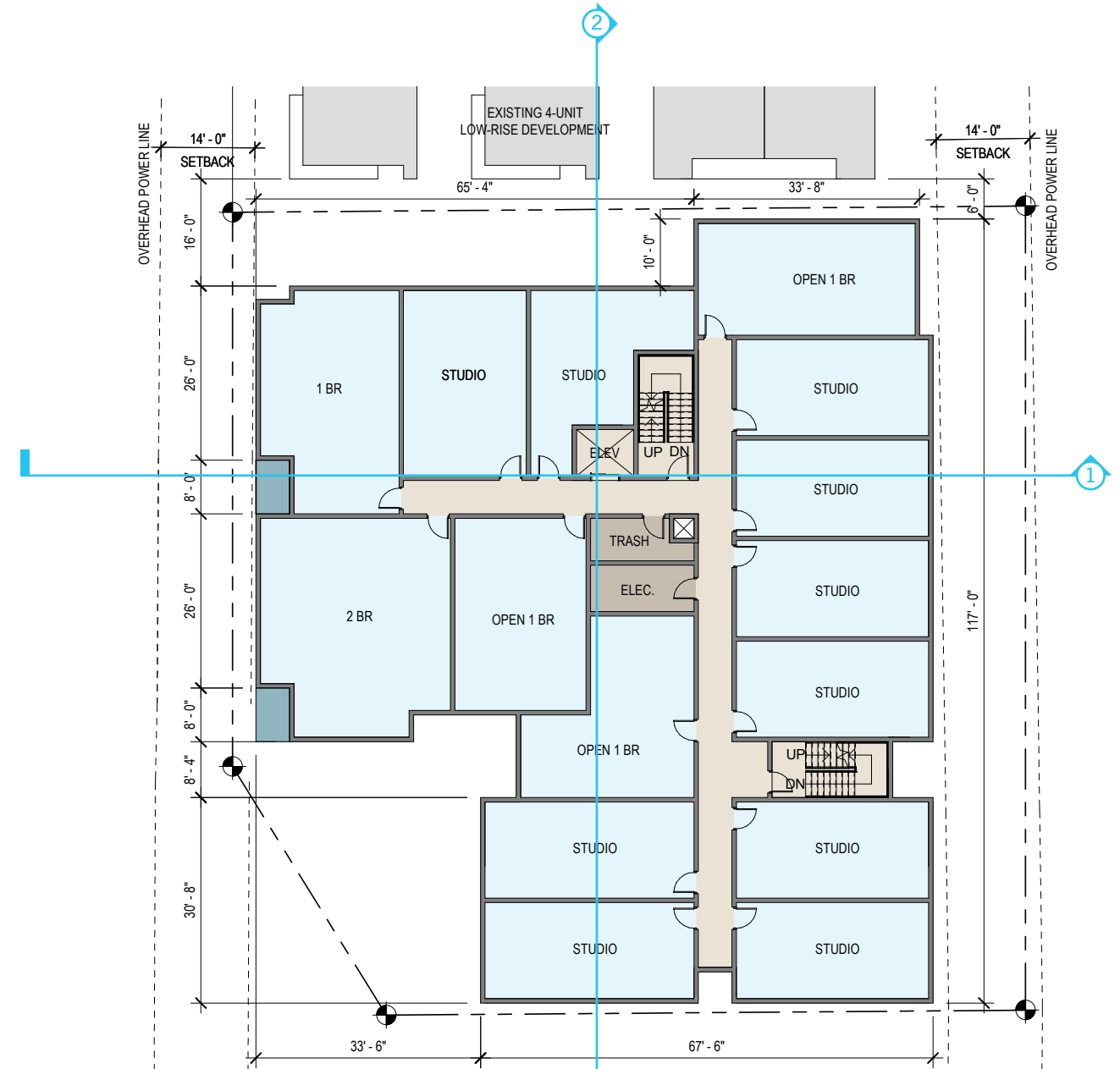

LEVEL 3-4



APPENDIX 2 | EDG 1 OPTION 3 (PREFERRED)

KEY

- Commercial
- Planting Strip
- Residential
- Residential Amenity
- Utility/BOH
- Parking/Garage
- Circulation
- Balcony

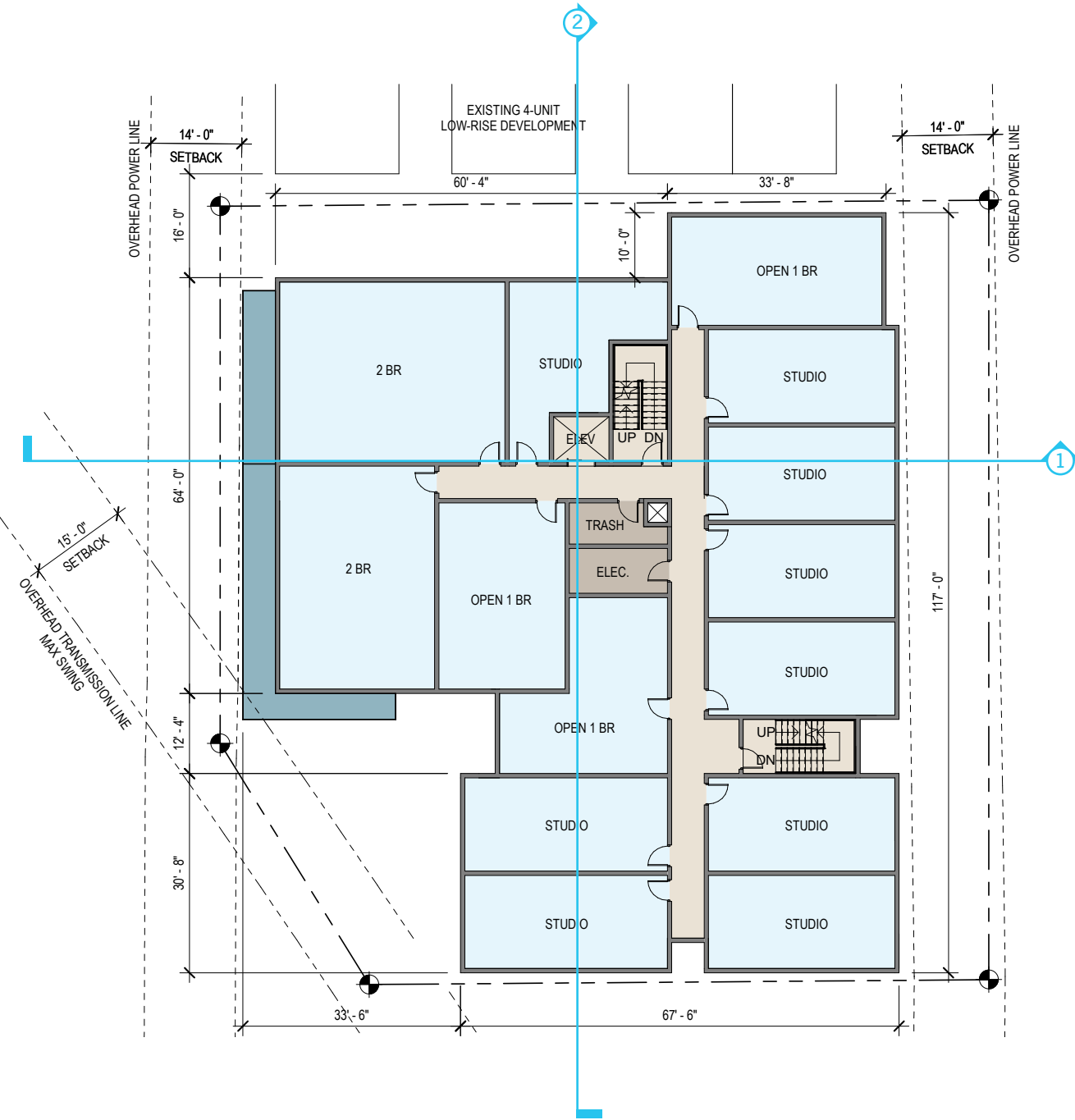

LEVEL 5

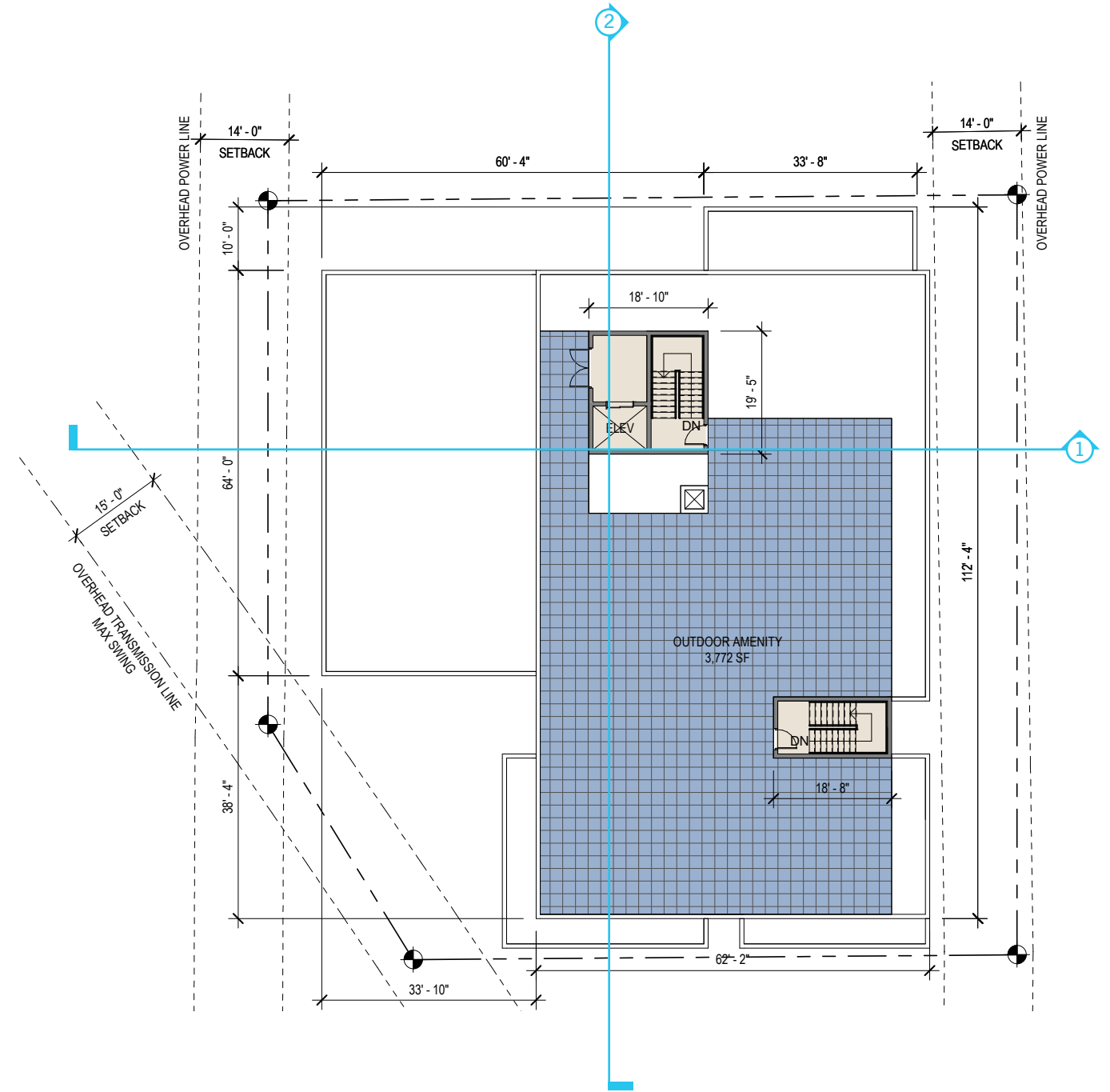

ROOF



APPENDIX 2 | EDG 1 OPTION 3 (PREFERRED)

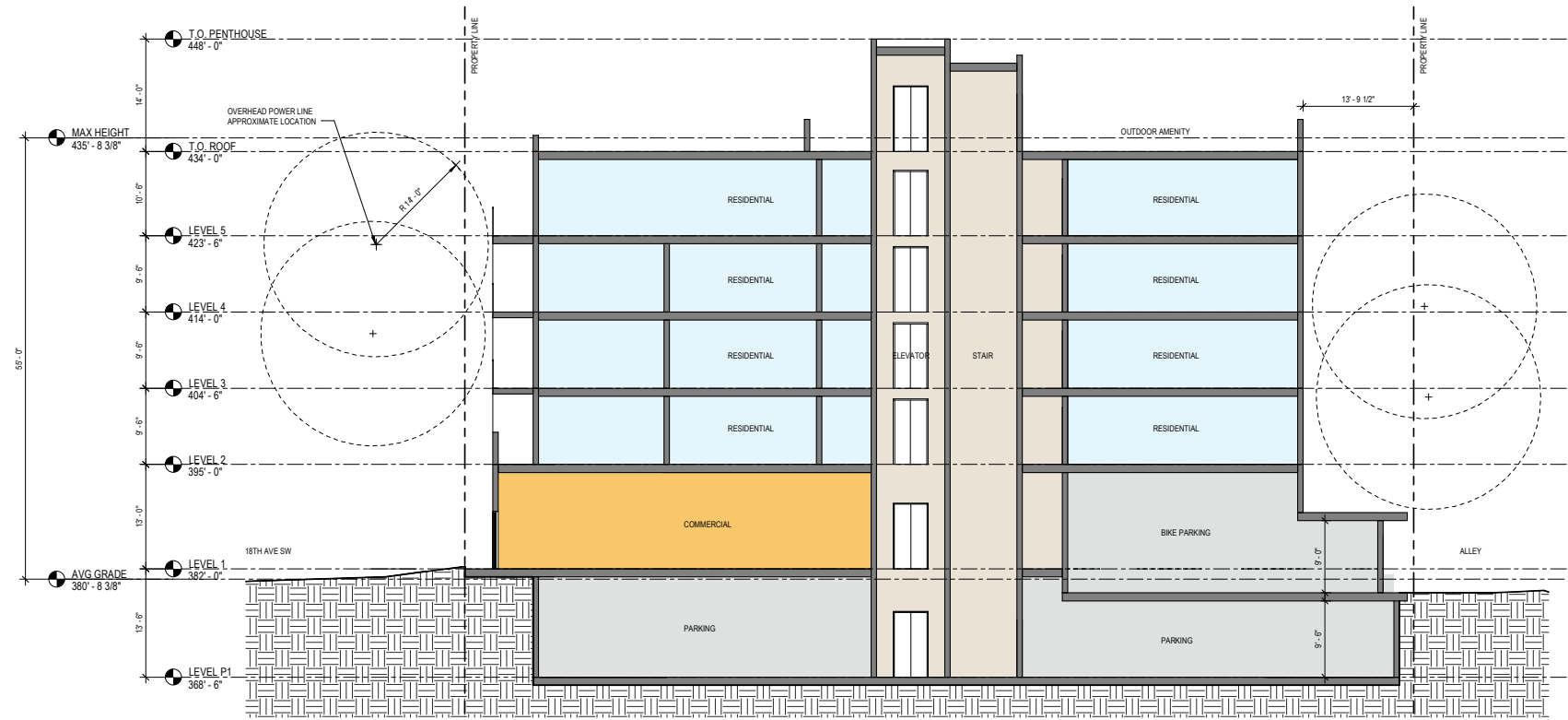

SECTION 1

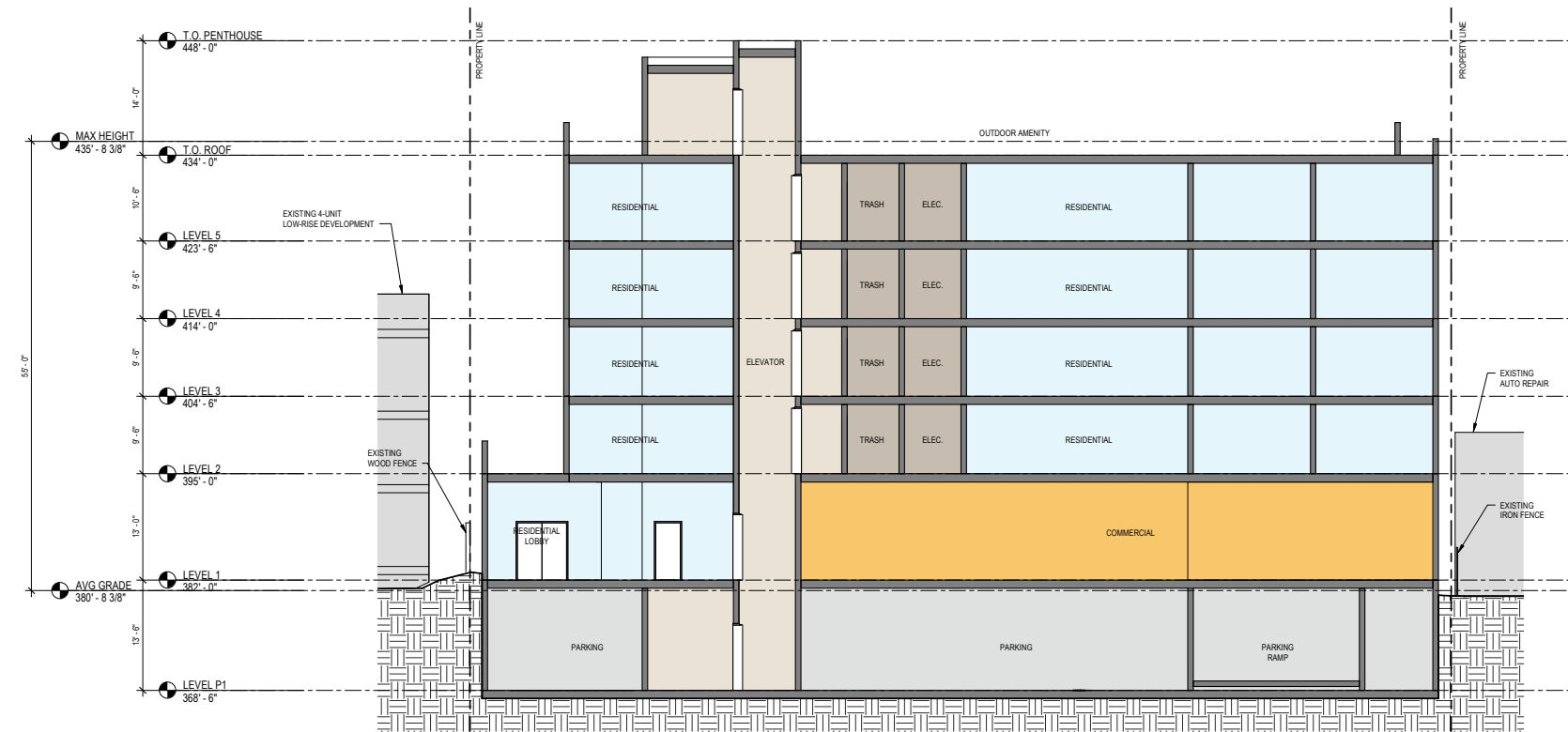

SECTION 2

- KEY**
- Commercial
 - Residential
 - Utility/BOH
 - Circulation
 - Parking

APPENDIX 2 | EDG 1 OPTION 3 (PREFERRED)

